

Product Change Notice



Please review this information to participate in the new Fortress Power app experience.

Fortress Power has just launched the new Fortress Power Owner and Pro app. **The best part is that we have made it compatible with the new and older generation of Fortress Power products including:**



eFlex
5.4kWh



eFlex Max
5.4kWh



eVault Max
18.5kWh



eForce



eBoost
16kWh



Envy Series
Inverters

To benefit from the new app experience, you will need one or multiple of the following:

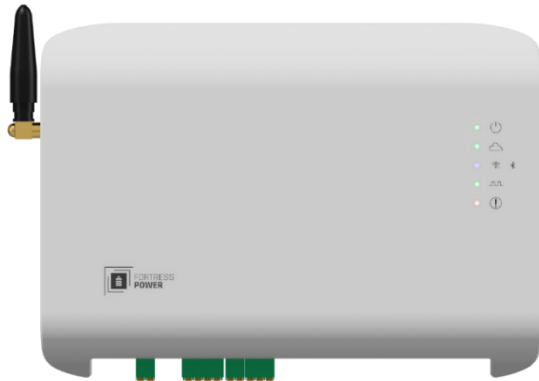

Figure 1: Guardian

Available Now

OR



Figure 2: Guardian Dongle

Included with FP-ENVY-DUO21 G (June 2026). Additionally, it will be available separately in June 2026

- You will need 1 device per Fortress Power Envy inverter.
- You only require 1 Guardian for battery systems installed with a third-party inverter. Please read Guardian manual to ensure proper communication cables are installed. After doing so please follow the steps in this guide

⚠ Never install a Guardian and a Guardian Dongle on the same Envy inverter. This will cause system issues.



Read before proceeding

- 1.** If you have a Guardian with Serial Number: starting with 2211, please contact Fortress Power tech support by submitting a support ticket at <https://www.fortresspower.com/support/support-ticket/>

Please make sure to attach a picture of the serial number located at the back of the Guardian:

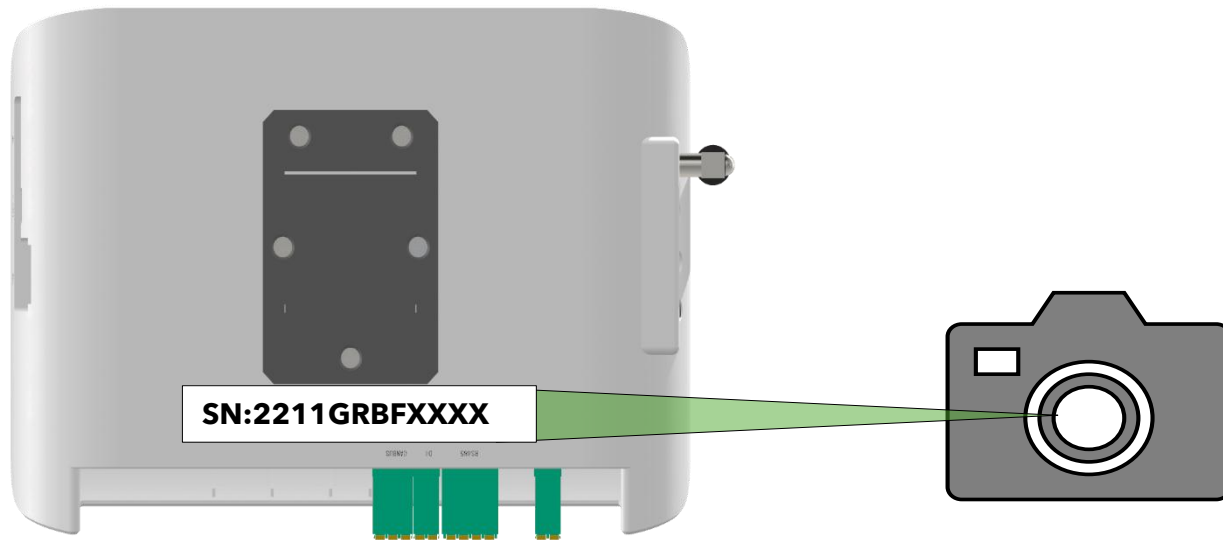

Figure 3: Guardian serial location

2.If you have an Envy inverter, please update the inverter to the latest firmware

Download the latest Envy inverter firmware using the Envy Dongle

There are 2 methods to do this:

Method 1. If the Inverter is connected to the internet, access the web portal at <https://envy.fortresspower.io>

Go to section: **Maintenance**>**Remote Update**>push **Standard Update**.

Serial number	Dongle	Firmware version	Connect Status	Action
1 4482720544	BA33800357	EAAB-2626	Connected	Update Standard Update
2 4482720545	BL44700383	EAAB-2122	Connected	Update Standard Update
3 4482720546	BL44700519	EAAB-2623	Connected	Update Standard Update
4 3102570073	BA30804758	EAAB-2123	Lost	Update Standard Update

You can also request Fortress Power technical support team to do this for you.

 The inverter will reboot several times during the firmware update which will result in momentary power loss.

Method 2. Local firmware updates using your phone.

1. Download the **Envy Fortress Power App** and access it.
2. Select **Download Firmware** on the Home Screen of the App
3. Select **Download**, and three files should download (less than 30s)
4. **Disable Cellular Data** (to prevent your cellphone from connecting or searching for data as this might interrupt the firmware update process)
5. Select **Wi-Fi** and Connect to the **dongles serial number** (usually starts with AA or BA)
6. Return to the **APP** and select **Connect Device and Update**
7. When updating, you should see **2 progress bars** in the app and a flashing green light in the inverter. While the firmware is being pushed, do not make calls, touch the LCD, or use the phone for anything else as this will cause firmware interruption. Do not allow your cellphone screen to dim or go to sleep mode. In the case of receiving a call or interruptions occur, you may reselect update firmware and the inverter will resume from where it left off.
8. You will receive an **Update Firmware Successful** message when both files have been pushed through.

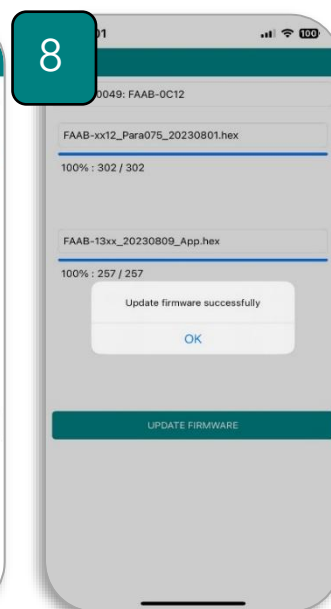
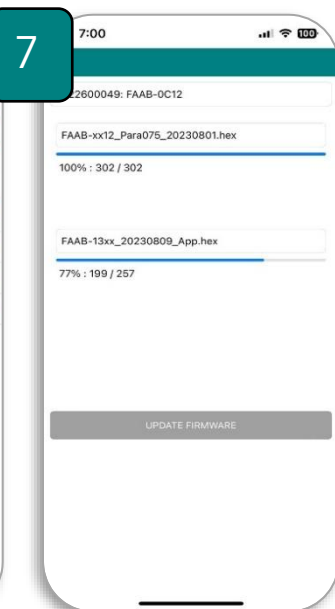
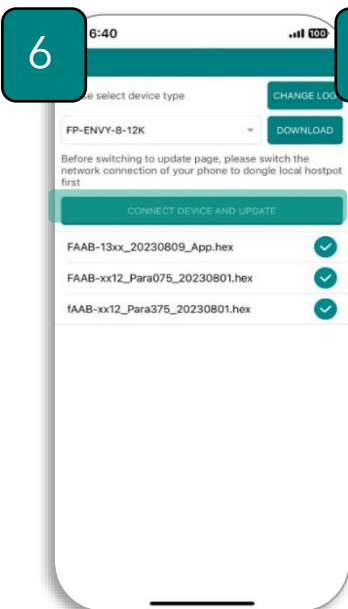
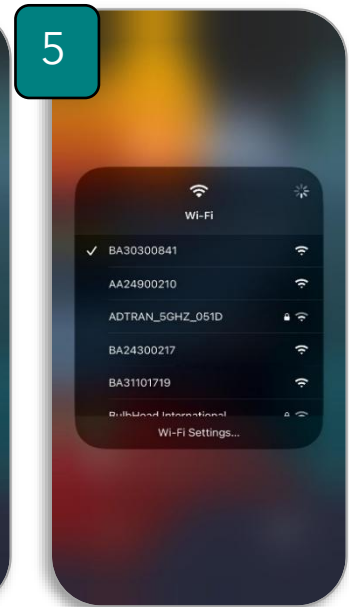
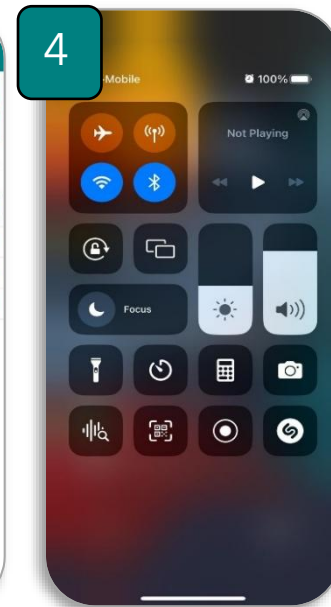
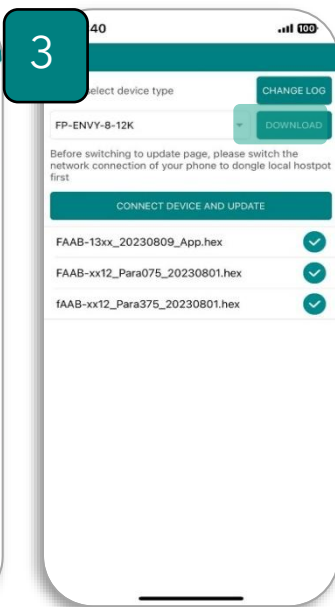
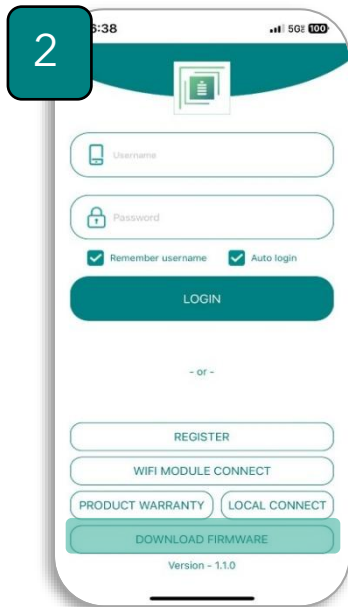

Installing the Guardian

Step 1. Plug in the Guardian to the inverter as shown in the picture below. You can skip this step if Guardian is already plugged to the Envy Inverter.

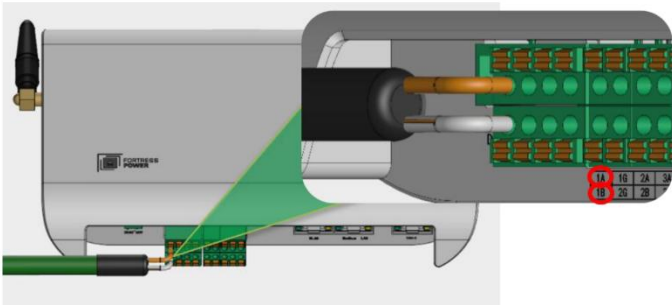

a. When setting up a Guardian with an Envy inverter, please use the two row/four column plug to wire into the Guardian connection port. For reference, the cable pin-out is **Orange/White** to the Guardian's RS485 **1A** and **Orange** to the Guardian's RS485 **1B**.

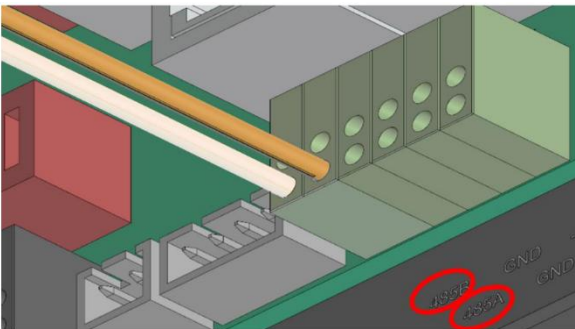

b. After you have finished wiring this step, please plug the other end of the Envy/Guardian cable into your INV485 port of the Envy inverter matching **Orange/White** to the **RS485A** port and **Orange** to the **RS485B**. Afterward, please go ahead and power on the Guardian and proceed with commissioning through the

Fortress Pro app.



You may use both Envy Dongle and Guardian simultaneously.

Step 2. Download the **Fortress Power Pro** App

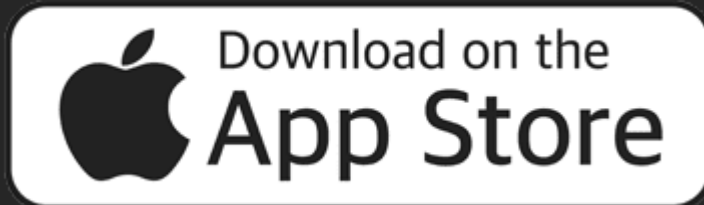

FORTRESS OWNER



FORTRESS PRO



Keystone

Access more details about your system by logging into the web portal at <https://my.fortresspower.io> once you have updated and re-register your Guardian with associated devices.

Step 3. Existing Customers: Access the **Fortress Power Pro App** If you have a previous Fortress Power Guardian or Avalon account. Please select **Forgot Password**. You will be redirected to create a new password. Once it is created, you may access the app. You may also use these credentials to access the **Fortress Owner App**

New Customers: Sign up. For DIYers or system owners, you may input **No Company** when prompted to put a company name in the sign-up process.

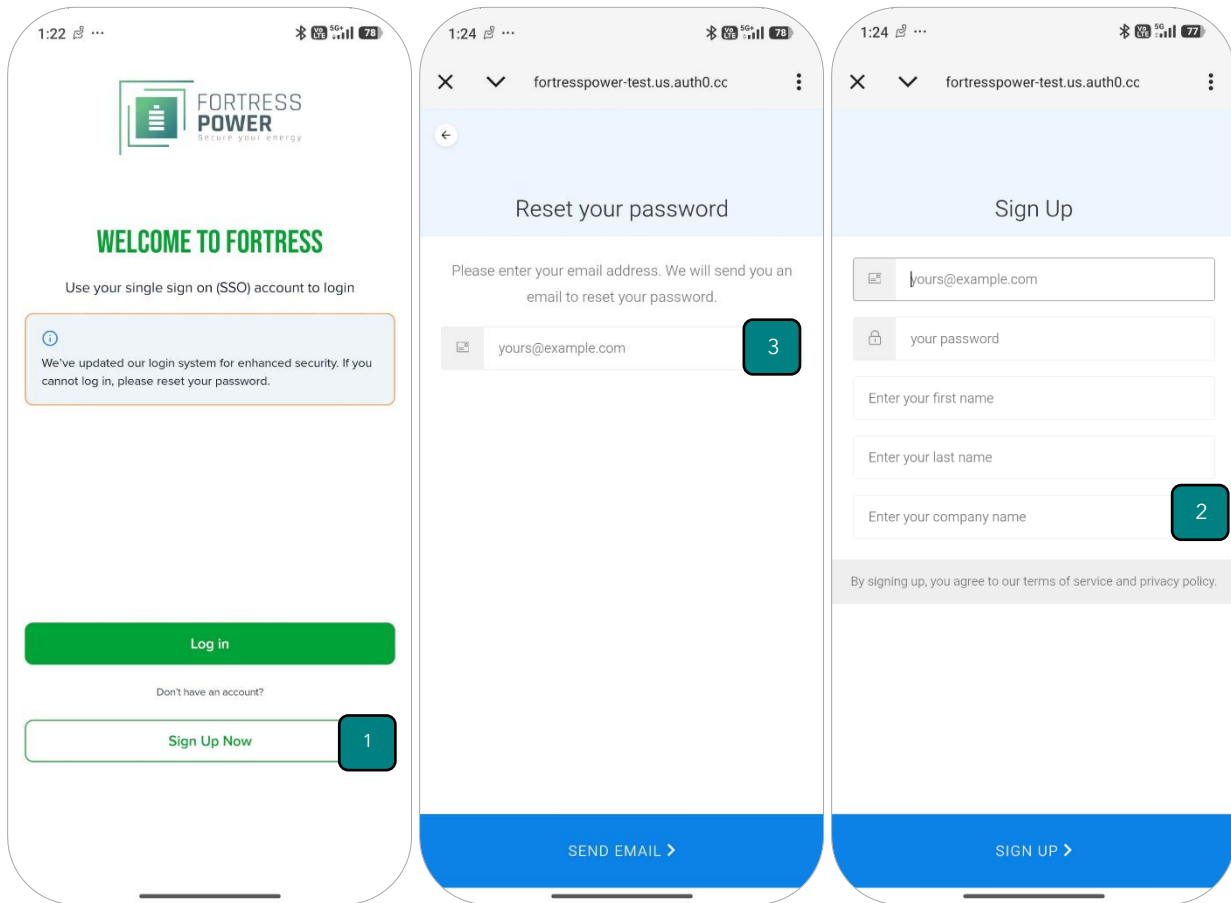

Step 4. Access the Firmware Update section of the Fortress Pro app and verify that the Guardian has the latest firmware. Update to the latest firmware.

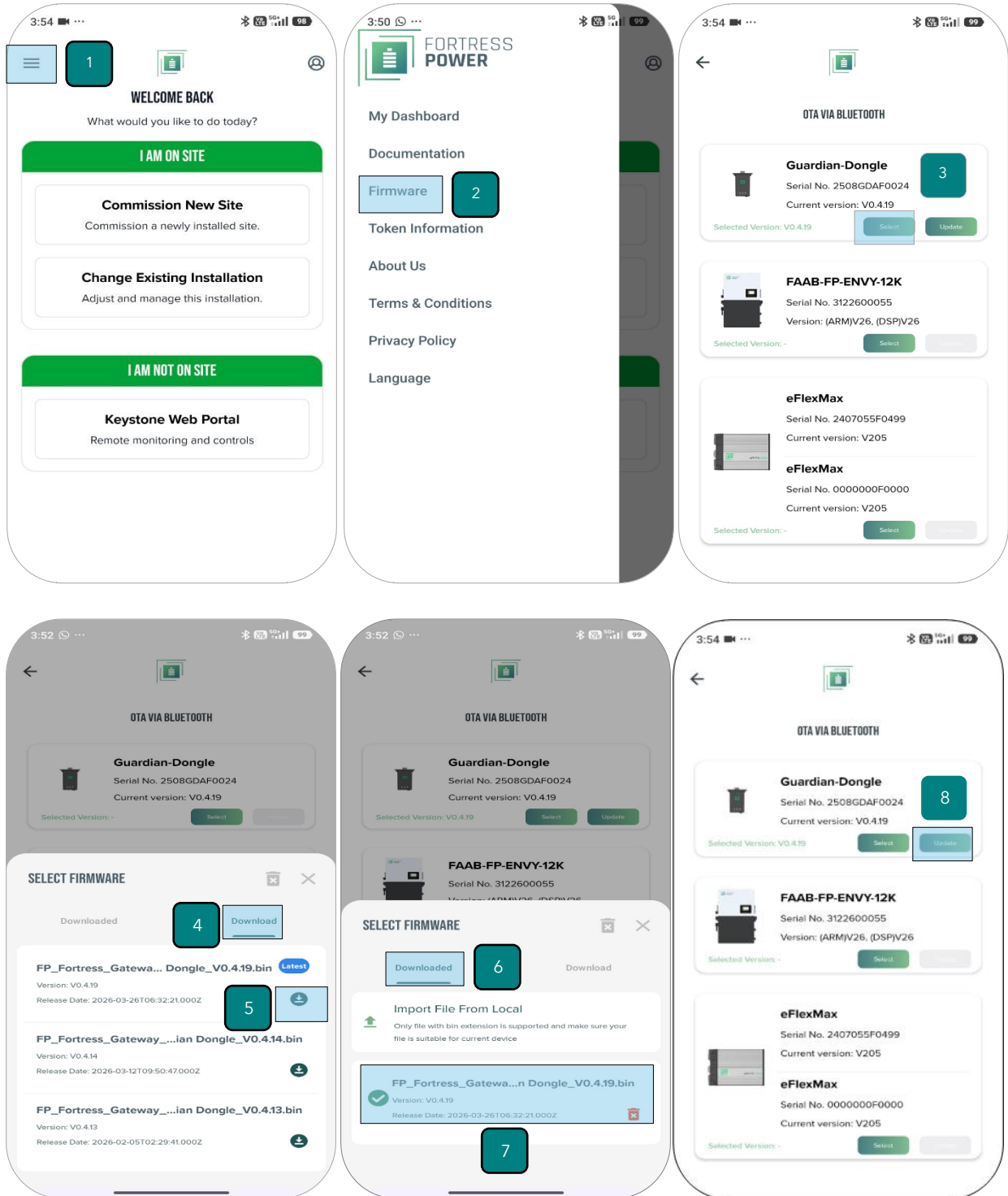

Step 5. Go through the commissioning process by selecting **“Commission a New Site”**. For users who already have an Envy system and do not want to reconfigure their inverters, choose **“Commission New Site”** and go through the user registration process. Once you arrive to the **Set the Inverter** section, select **“I already have everything set via the LCD”** allowing you to bypass the commissioning process. This process will automatically register the system to the cloud.

