



FORTRESS LITHIUM BATTERY INSTALLATION MANUAL

SECURE YOUR ENERGY WITH FORTRESS LITHIUM BATTERY SYSTEMS

Fortress battery systems utilize the industry's most environmentally benign chemistry- Lithium Ferro Phosphate, which eliminates operating temperature constraints, toxic coolants and the risk of thermal runaway and fire. The built-in smart Battery Management System (BMS) integrates multilevel safety concepts: Overcharge and Deep Discharge Protection; Voltage and Temperature Observation.

Fortress High-performance Lithium Batteries are manufactured at the highest quality standard. It comes with large power capacity and a fast charging and continuous discharge power. The proprietary architecture and BMS eliminate the need for cooling or ventilation, which creates an efficient round-trip conversion.

Fortress Lithium Battery is safe, easy to install, consistently reliable, highly efficient. It provides you the lowest lifetime energy cost.

This installation manual contains information concerning important procedures and features of Fortress Power Lithium batteries. Read all the instructions in this manual before installation, operation, transportation, storage and maintenance.

Table of Contents:

1. SAFETY	
1.1 General safety precautions and Safety instructions	3
2. TRANSPORTATION, HANDLING AND STORAGE	
2.1 Transportation and Handling.....	4
2.2 Storage.....	4
2.3 Response to emergency situations	5
3 PRODUCT INTRODUCTIONS	
3.1 Technical data	5
4. INSTALLATION	
4.1 Tools and material list for installation.....	6
4.2 Inspection before installation.....	6-7
4.3 Installation Location.....	7
4.4 Installation Steps.....	7-8
4.5 Connection Terminals.....	8
4.6 Mounting Hardware.....	8-9
4.7 Final Connection of the Installation.....	10
5. PARALLEL CONNECTION.....	10-11
6. Retrofitting.....	11
7. OPERATING	
7.1 Operating environment.....	11
7.2 Charging.....	11-12
7.2.1 Charging stage	12
7.3 Discharging	12
7.4 Parameter set up guide in Charger/Inverter	12-13
8. TROUBLE SHOOTING.....	13-14
9. SERVICE AND MAINTENANCE.....	14

1. SAFETY

1.1 General safety precautions

- ❖ All types of breakdown of the product may lead to a leakage of electrolyte or flammable gas.
- ❖ During installation of the battery, the utility grid, solar input must be disconnected from the Battery Pack wiring. Wiring must be carried out by qualified personnel. Battery Pack is not user serviceable. High voltage or current is present in the device. The electronics inside the Battery Pack are vulnerable to electrostatic discharge. Observe the following precautions:
 - ❖ Risks of explosion
 - Do not subject the battery pack to strong impacts.
 - Do not crush or puncture the battery pack.
 - Do not dispose of the battery pack in a fire.
 - ❖ Risks of fire
 - Do not expose the battery pack to temperatures in excess of 122 °F.
 - Do not place the battery pack near a heat source such as a fireplace.
 - Do not expose the battery pack to direct sunlight.
 - Do not allow the battery connectors to touch conductive objects such as wires.
 - ❖ Risks of electric shock
 - Do not disassemble the battery pack
 - Do not touch the battery pack with wet hands
 - Do not expose the battery pack to moisture or liquids
 - Keep the battery pack away from children and animals.
 - ❖ Risks of damage to the battery pack
 - Do not allow the battery pack to come into contact with liquids.
 - Do not subject the battery pack to high pressures.
 - Do not place any objects on top of the battery pack.



IMPORTANT NOTE: Circuit Breakers, Disconnects and Fuses should be employed throughout several points of a power storage and generation installation to effectively isolate and protect all components of the system to safeguard against faults, short circuits, polarity reversals or a failure of any component in the overall system. Fuses, breakers, wiring ratings and values should be determined by established standards and evaluated by certified electricians, licensed installers, and regional code authorities. The Fortress Lithium Batteries must always be installed with a charge controller and the appropriate settings to protect the batteries from open PV voltage and other high voltage charging sources. The Fortress Battery Management System (BMS) alone will not protect the batteries from these extreme electrical phenomena. Failure to adhere to installation protocol will void the Warranty.



CAUTION: Verify polarity at all connections with a standard volt meter before energizing the

system. Reverse polarity at the battery terminals will void the Warranty and destroy the batteries. Do not short circuit the batteries.

Most batteries pose some risk of shock or sparking during the installation and initial wiring and connection process. Wearing insulated gloves, clothing and footwear and using electrically insulated tools are required when working with Fortress Power Lithium Batteries. Cover, restrain or remove jewelry or conductive objects (metal bracelets, rings, belt buckles, metal snaps, zippers, etc.) when working with any electrical or mechanical device. Cover or restrain long hair and loose clothing when working with any electrical or mechanical device.



CAUTION: Do not combine Fortress Lithium Batteries with other brands or chemistries; Do not mix Fortress Lithium Batteries from different installations, clients, or job sites.



CAUTION: Do not disassemble or modify the battery. If the battery housing is damaged, do not touch exposed contents.

2. TRANSPORTATION, HANDLING AND STORAGE

2.1 Transportation and Handling

Do not knock, drop, puncture, or crush battery; Do not expose battery to flames, incinerate or direct sunlight; Do not open battery case or disassemble battery; Do not lift battery by the terminal cables; Do not vibrate battery; Do not expose battery to water or other fluids; Do not expose battery to open flame; Do not place the product nearby highly flammable materials, it may lead to fire or explosion in case of accident; Store at cool and dry place. (Do not store in greenhouses and storage areas for hay, straw, chaff, animal feed, fertilizers, vegetables or fruit products; Store the product on a flat surface; A ventilated area is strongly recommended for handling the product; Store the product out of reach of children and animals; Store the product where it should be minimal dust and dirt in the area; do not transport battery upside down;

2.2 Storage

Do not expose battery to high temperatures. Fortress Lithium Batteries should be stored out of direct sunlight under the following temperature conditions.

Storage Temperature (Min./Max.): 41°F/5°C – 95°F/35°C

Relative Humidity (Min./Max.): 5%~75% RH

Systems should be put into storage at 60% SOC and checked monthly to ensure the system SOC does not fall below 20%. At 20% SOC the battery will self-discharge in approximately 2 months. Also check the voltage every 3 months and recycle every 6 months if the battery is not use for long time.

2.3 Response to emergency situations

The battery pack comprises multiple batteries that are designed to prevent hazards resulting from failures. However, Fortress Power cannot guarantee their absolute safety.

❖ Leaking Batteries

If the battery pack leaks electrolyte, avoid contact with the leaking liquid or gas. If one is exposed to the leaked substance, immediately perform the actions described below.

- **Inhalation:** Evacuate the contaminated area and seek medical attention.
- **Contact with eyes:** Rinse eyes with flowing water for 15 minutes and seek medical attention.
- **Contact with skin:** Wash the affected area thoroughly with soap and water, and seek medical attention
- **Ingestion:** Induce vomiting, and seek medical attention

❖ Fire

In case of fires, make sure that the extinguisher is available near the battery pack. If possible, move the battery pack to a safe area before it catches fire.

Note: Fire extinguisher

Water, carbon dioxide, dry chemical powder and foam are the most effective means to extinguish a Lithium Ferrous Phosphate (LFP) battery fire

Use ABC Fire extinguisher, if the fire is not from battery and not spread to it yet.

3. PRODUCT INTRODUCTION

3.1 Technical data

Model	LFP-10	LFP-15
Total Energy(kWh)	10.24	15.36
Max. Charge Current (Continuous) [A]	100	100
Max. Discharge Current Continuous) [A]	100	100
Max Pulse Current for 5sec [A]	200	200
Capacity [Ah]	200	300
Voltage [V]	51.2 (48)	51.2 (48)
Charging Temperature [F]	32~113	32~113
Discharging Temperature [F]	-4~140	-4~140
Dimension [WxDxH]	16.4x9.4x33	16.6x13.4x33
Packaging Dimension [WxDxH]	34x20x12	34x20x15
Connection Terminal	M10	M10
Weight [Lb]	286	429
Scalability	Up to 2	Up to 2

4. INSTALLATION

Safe and reliable installation requires trained and certified technicians. The following discussion of Fortress Power Battery configurations is a basic primer. Due to the variety of systems and components in the field, all possible scenarios are not covered. This is not the purpose of this section of the manual. Refer to professional installers regarding your system and its components and specifications. We encourage you or your installer to contact us with any specific questions for technical support. We are committed to working with you and your installation team to achieve a safe, reliable storage system that will provide years of maintenance free service.



Fortress Lithium Batteries are designed for parallel operation only - do not arrange in series for increased voltage. Series arrangement can result in damage to Fortress Lithium Batteries and will void warranty!



Do not combine Fortress Power Battery with other brands or chemistries. Do not mix different capacity batteries, do not mix batteries from different installations, or job site.

4.1 Tools & Materials

- ❖ Insulated tools and materials are various from projects, following are general recommendations:
 - Wire recommendation: AMG02
 - Terminal luge recommendation: 3/8 inch
 - Conduit size Recommendation: 3/4, 1 & 1 ¼ inch
 - OSHA approved personal protective equipment

		
Insulated gloves	Safety Glasses	Safety Shoes

4.2 Inspection

- To check the battery package, type, quantity, appearance and other components
- Check if there is any damage on the battery box

- Check the battery terminals and connections to make sure they are clean, free of dirt, fluids and corrosion
- All battery cables and their connections should be tight, intact, and NOT broken or frayed
- Replace any damaged batteries and cables
- Check torque on terminal bolts



IMPORTANT NOTE: Please inform us within 7 days after receipt of goods if any problems, otherwise we deem clients have no objection to the goods.

4.3 Installation Location

The battery pack must be installed indoors. Make sure that the installation location meets the following conditions:

- The area is completely waterproof.
- The floor is flat and level (Inclination < 15°).
- There are no flammable or explosive materials.
- The optimal ambient temperature is within the range from 59 °F to 95 °F.
- The temperature and humidity are maintained at a constant level.
- There is minimal dust and dirt in the area.



IMPORTANT NOTE: If the ambient temperature is outside the operating range, the battery pack may stop operating to protect itself. Frequent exposure to harsh temperatures may deteriorate the performance and life of the battery pack.

4.4 Installation Steps

- Clean cable connections. Broken, frayed, brittle, kinked or cut cables should be replaced
- Install and secure new battery. Be careful not to ground the terminals to any metal mounting, fixture, or body part
- Connect battery cables first and ground negative cable to avoid sparks
- Recommended terminal torque is 7.0 – 7.7 Nm (5.1 – 5.7 ft-lb)
- Power Cabling for the Fortress Power Battery is not included. System Wiring Basics Refer to published electrical wiring specifications and ratings, refers to the below Battery Cable Sizing Chart. Your qualified installer or application specifications will determine the wire gauge for your system.



CAUTION: Verify polarity at all connections with a standard volt meter before energizing the system. Reverse polarity at the battery terminals will void the Warranty and destroy the batteries. Do not short circuit the batteries.

4.5 Connection Terminals

The Fortress Lithium Batteries are equipped with two M10/M8 threaded terminals with a lock washer and nut. The right-hand stud resides in a red high temperature molded insert. This connection is for the positive lead. The left-hand stud resides in a black high temperature insert. This connection is for the negative lead. 10mm ring terminals along with proper size wiring cables are required to connect battery to inverter/charger. Do not reverse polarity, doing so will void warranty. Use a volt meter to check polarity before connecting terminals.

Water Resistant Plastic Terminal Covers are also included and will be in place when your units arrive. The boots are to be placed over the cable terminations and will stretch to form a water-resistant seal around the base of the molded inserts and terminal connections.



NOTE! Without exception, product experiencing terminal burn out will not be warranted.

4.6 Mounting Hardware

The Fortress Power Batteries are designed to stand on the floor with 4 wheels on the bottom. If it's wished, the wheels can be disassembled. It's recommended to put the Batteries on durable racks to avoid flooding. Please refer to the Fortress Lithium Battery Data Sheet for weight and dimension.

Mounting the battery pack to a wall

It is recommended to mount the battery pack to a wall. Make sure to leave a space of at last 2.18 inches in between the battery pack and the wall

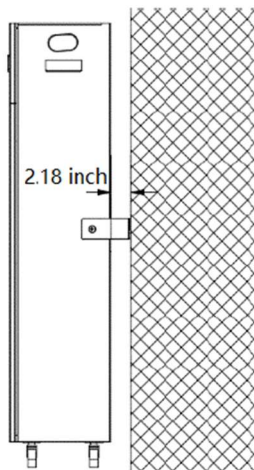

To mount the battery pack to a wall, take the following steps:

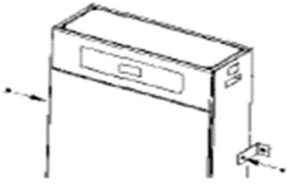
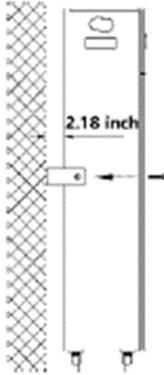
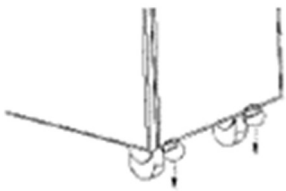
	<p>1. Fasten the screws through the mounting brackets into the holes of the battery pack on its both sides.</p>
	<p>2. Secure the mounting brackets to the wall with screws.</p>
	<p>3. Lock the rollers on the battery pack</p>

KEY POINTS SUMMARY:

1. Each Fortress Lithium Battery contains circuitry that protects the Lithium Ferro Phosphate cells from overcharging, over-discharging, and excessive load amperage. If the values specified are exceeded, the battery will enter a protective shut down state. In some cases, this may result in the need to re-initialize an inverter charger or other pieces of equipment in the installation. In other cases, the inverter's system settings may be saved within the inverter memory storage and will not need to be reset. This is not an absolute standard but is common among most inverter chargers. Check your inverter manufacturer specifications.

2. If the battery enters a self-protective mode, negligible voltage readings will be present until the unit is reset. In some instances, after a prolonged shut down, a charge might need to be manually applied to the energy storage bank. Should this occur, please contact Fortress Power for technical support. Fortress Lithium Batteries are designed to remain robust and safe under most circumstances.

3. Although each Fortress Lithium Battery contains circuitry that protects the Lithium Ferro Phosphate cells from overcharging, over-discharging and excessive load amperage, Fortress Lithium Batteries must always be installed with a charge controller and the appropriate settings to protect the batteries from open PV and other high voltage sources. Fortress Lithium Batteries alone will not protect from extreme electrical phenomena.

4. GRID TIED SYSTEMS: Once the Fortress Lithium Battery has been installed, turn on the entire system to test. Once testing has been completed, please disconnect the batteries from the load center until your local Utility Inspector is ready to turn on the entire system. The charge controllers and inverter monitoring systems can drain the Fortress Lithium Batteries over an extended period when the entire system is not fully operational due to the electrical draw of the system components.

5. OFF GRID SYSTEMS: Do not connect the Fortress Lithium Batteries until the entire system is ready to turn on and is fully operational.

6. See Charge Controller Settings in the Appendix of this manual. Fortress Lithium Batteries are compatible with almost all Inverter Chargers and Charge Controllers. Please contact Fortress Power to learn the recommended settings for any device not explicitly covered in this manual.

4.7 Final Connection of the Installation

Final installation and operation guidelines will be dictated by your Electrician and Installer based on the overall properties of and procedures for the equipment in your installation and any code requirements that apply to your region. Fortress Power technicians and sales staff are available to provide any additional information on the Fortress Lithium Batteries as needed. Please be aware of the potential electrical hazards before interacting with any and all electrical or mechanical devices. Please take all necessary safety precautions in your projects and installations.

5. PARALLEL CONNECTION

Fortress Lithium Batteries with the same capacity may be connected in parallel for up to 2 units only. All wires should be an appropriate gauge and constructed to handle the loads that will be placed upon it. Heavy gauge, high strand copper wire is the industry standard due to its stability, efficiency and overall quality. A qualified installer should understand this and must adhere to the industry standard and published electrical guidelines.



CAUTION! Fortress Lithium Batteries are designed for parallel operation only - do not arrange in series for increased voltage. Series arrangement can result in damage to Fortress Lithium Batteries and will void warranty!



CAUTION! For parallel connecting: Maintain identical wire lengths from each Fortress Power Battery terminal to the common bus. Use identical wire construction from each Fortress Power Battery terminal to the common bus.

Storage Capacity and total available Amperage is increased by Parallel arrangements. The following illustration shows two Fortress Lithium Batteries in Parallel. Note the overall Voltage range is not changed. The available amperage from the system has been doubled. The following illustration shows two Fortress Lithium Batteries in Parallel.

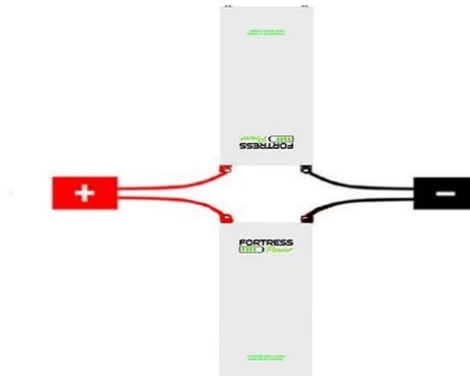

CAUTION! Before you turn on the two parallel connected Fortress Power Batteries, make sure both batteries have the same State Of Charge (SOC) and the voltage difference between two battery pack shall not over 0.2 voltage to avoid the current flow from the higher voltage battery into the lower voltage battery. The large current could potentially damage one or both batteries.

6 RETROFITTING

Retrofit Fortress Lithium batteries to an existing system is not recommended. Like all other batteries, Fortress Lithium Battery's open voltage will diminish during the operation. Parallel batteries with different open voltage may cause reverse currents, which could damage the batteries.

7 OPERATING

7.1 Operating environment

Model	LFP-10	LFP-15
Charging Temperature [F]	32~113	32~113
Discharging Temperature [F]	-4~140	-4~140

7.2 Charging

Never attempt to charge a battery without first reviewing and understanding the instructions for the charger being used. Only use a Fortress Power Approved Lithium Ferro Phosphate (LFP) charger if ancillary charging is required before installation, testing or troubleshooting. Failure to use a Fortress Power approved LFP charger will damage the battery and void the warranty



CAUTION! Do not attempt to charge the battery below 32 F (0 degrees C). Attempts to charge at subfreezing temperatures can adversely affect State of Health (SOC) and cycle life

and will void the warranty; never charge battery if it is frozen; never charge a visibly damaged battery.

7.2.1

Please follow the following steps to use the charger to charge the battery:

- 1) Connect the charger leads to the battery.
- 2) Make sure that the charger lead, both at the charger and the battery side, connections are tight.
- 3) Turn the charger on



CAUTION! Recommended charging current is 50A, Max. 100A (Please follow the specification on Fortress Lithium Battery Datasheet.)

7.3 Discharging

- Do not discharge battery below operating voltage
- Do not discharge battery at rates greater than maximum continuous current
- Do not operate in conditions that will exceed the internal operating temperatures of the battery

7.4 Parameter set up guide in Charger/Inverter

Before commissioning the energy storage system, the appropriate controller and inverter settings must be programmed per the manufacturer's recommendations. Consult the manufacturer's manuals and/or access technical support (Darfon, Schneider, Outback, SMA, Sol-Ark, Magnum, Outback).

Although Fortress Lithium batteries can perform at very high rates and depths of discharge within a very wide temperature range, in order to achieve extended life cycles and to comply with the Warranty, the following guidelines should be followed:

Understand Charge Stage

- 1) Bulk Charge: Charge at Constant Current (CC) to Bulk/Absorb Voltage
- 2) Absorption Charge: Maintain Constant Bulk/Absorb Voltage (CV)
- 3) Terminate when charge current drops below 0.05C and
- 4) Unlike Lead Acid batteries, Lithium Ferro Phosphate batteries do not require Float Charge

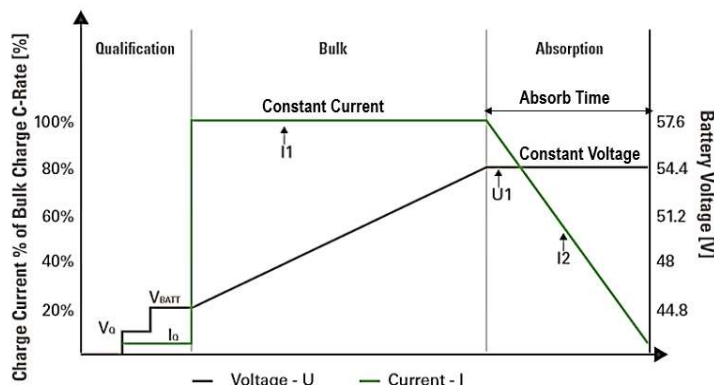

Charger/Inverter configuration recommendation for best Performance:

Schneider/outback/ SMA/Sol-Ark	3000 Cycles	6000 Cycles
Equalized Support	Off	Off
Capacity Limit	LFP-10:200 Ah / LFP-15:300 Ah	
Equalized Voltage	Off	Off
Recharge Voltage	47V	49V
Bulk Voltage	57.6V	55.4V
Absorb Voltage	57.6V	55.4V
Low Battery Cut Out Voltage	48.4V	50.7V
High Battery Cut Out Voltage	58V	56 V
Float Voltage	OFF/unless use as back up 54.4V	
Max Charge Current	100A per battery	50A per battery
Max Discharge Current	100A per battery	100A per battery

The Battery Parameter Setting Guides with Schneider and Outback Inverters/Chargers are available to download on www.fortresspower.com/Resource

Recommended operating parameters of charger/Inverters For 3,000 Cycles:

- Operating temperature range: 32 F to 120 F (0 °C to 49°C)

Recommended operating parameters of charger/Inverters For 6,000 Cycles:

- Operating temperature range: 32 F to 110 F (0°C to 43°C)
- Storage must be equal to or more than twice the rated output of the Inverter

At the End of Cycle Life capacity is Equivalent to 70% Retained Capacity



CAUTION! Do Not Operate Fortress Lithium Batteries at an average temperature exceeding 30 °C / 86 F over the life of the battery.

8. TROUBLESHOOTING

The Battery BMS provides multiple level protection function:

- Over Charge Voltage Protection
- Over Discharge Protection
- Over Current Protection for Discharge Via Thermal Control
- Short Circuit Protection
- ON/OFF Switch

In the event of a fault the battery protection circuit will open its internal relay/mosfet disconnecting the negative battery terminals from the internal cells. The battery uses a relay/mosfet and precautions should be taken to reduce voltage spikes and large inductance in the application.

Over Voltage Fault	62.4±0.4V
Over Voltage Recovery	60.8±0.8V

Low Voltage Fault	32.0±0.8V
Low Voltage Recovery	36.80±1.6V

If batteries enter a self-protective mode, negligible voltage readings will be present until the unit resets. In some instances, after a prolonged shut down, a charge might need to be manually applied to the energy storage bank. Should this occur, please contact Fortress Power for technical support. Fortress Lithium Batteries are designed to remain robust and safe under most circumstances.

9. SERVICE AND MAINTENANCE

Batteries should be carefully inspected on a regular basis in order to detect and correct potential problems. This routine should be started when the batteries are first received.



PLEASE CONTACT US FOR TECHNICAL SUPPORT

Fortress Power, LLC
 505 Keystone Road,
 Southampton, Pennsylvania, 18966
 877.497.6937
sales@fortresspower.com
www.FortressPower.com