



Fortress Power

Energy Storage Systems

Paul Stepanoff, PE

Topic

- Growth Opportunity
- Company Introduction
- Fortress Lithium Battery
- Compatible Inverters
- Integration Guide
- Battery Technology Comparison
- Design and Install Guide



Growth Opportunity



US Energy Storage Market

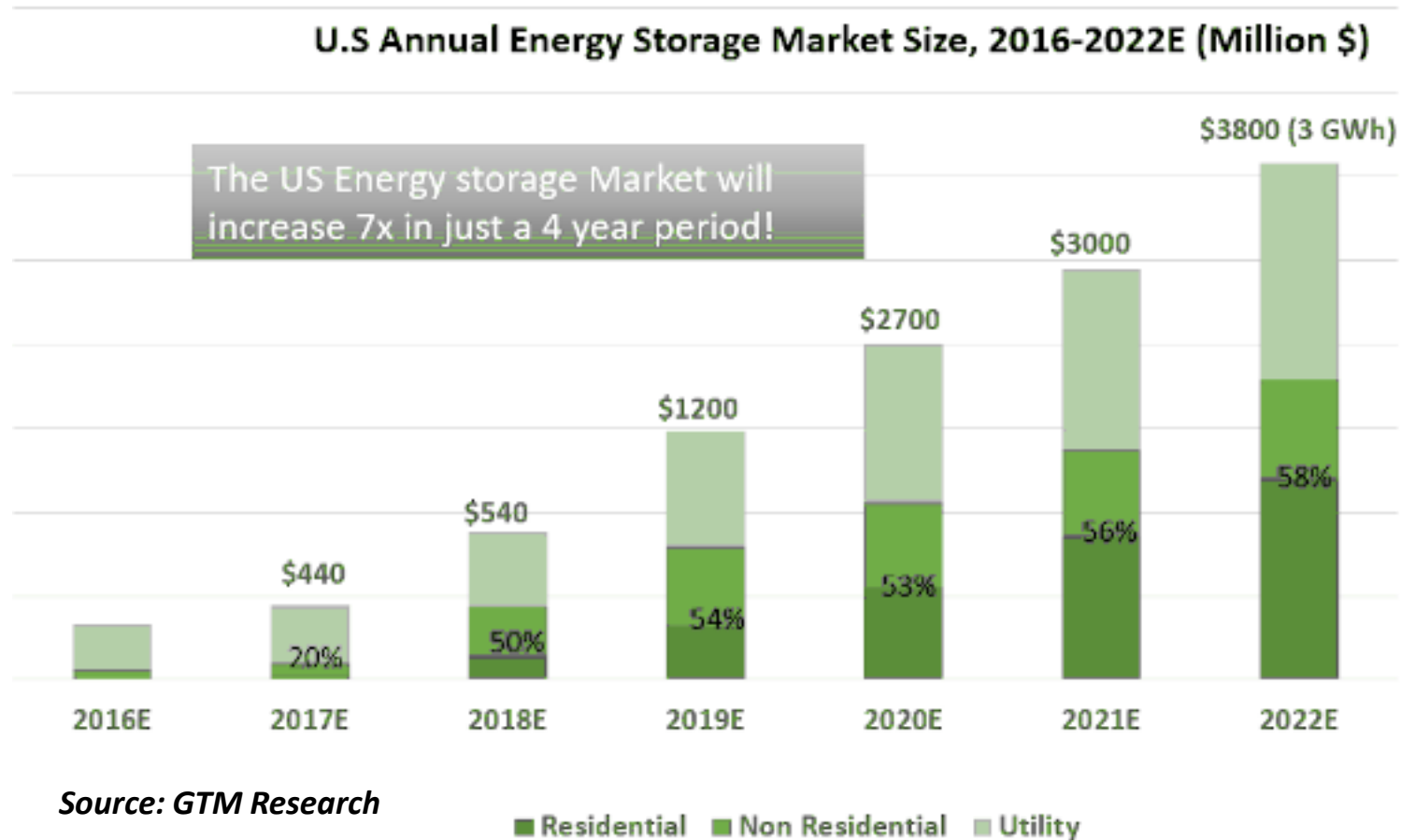

Central & Latin America Energy Storage Market

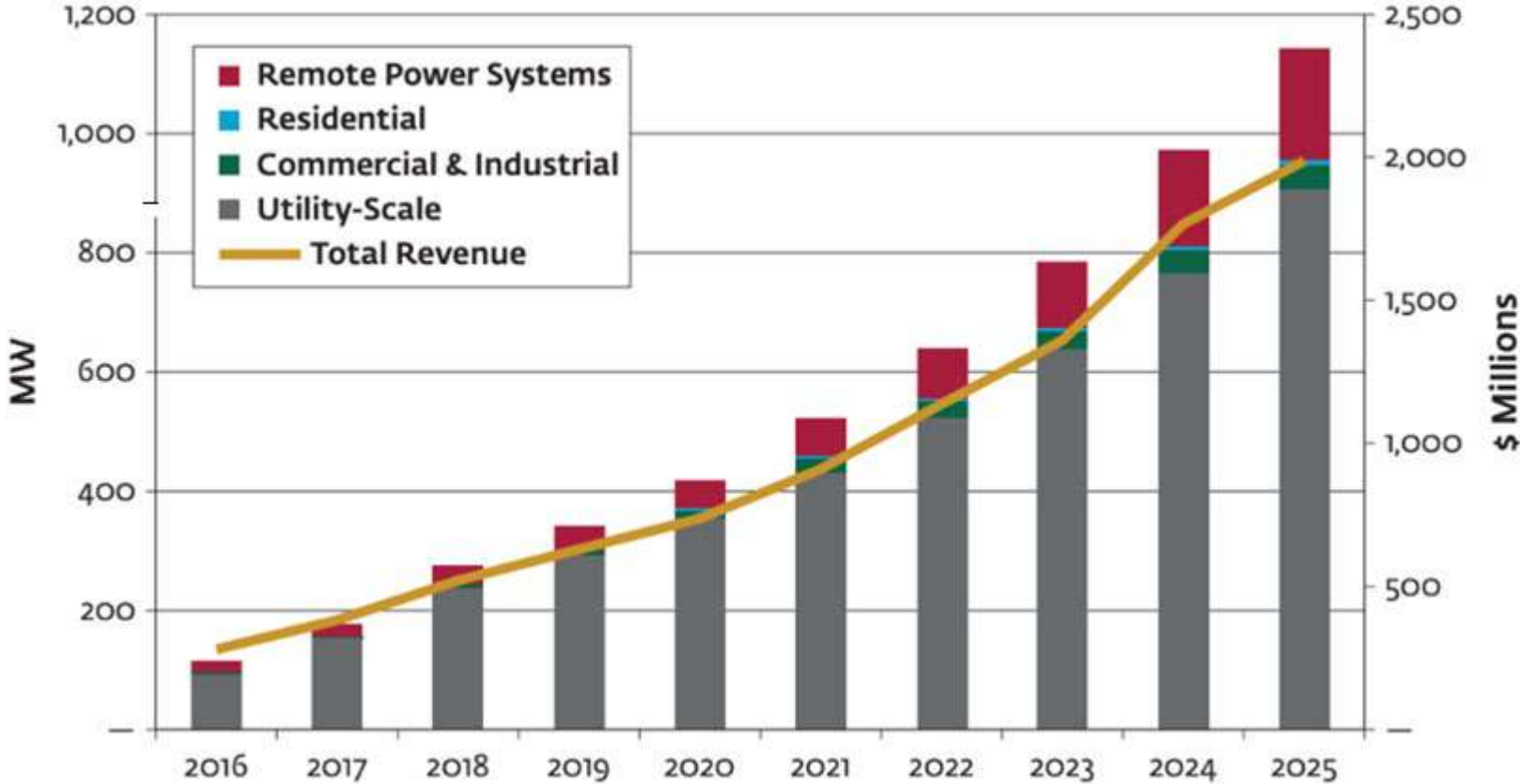

Annual stationary Energy Storage Deployments by Segments Central & Latin America, (2016-2025); Source IFC ES Report

Energy Storage Benefits

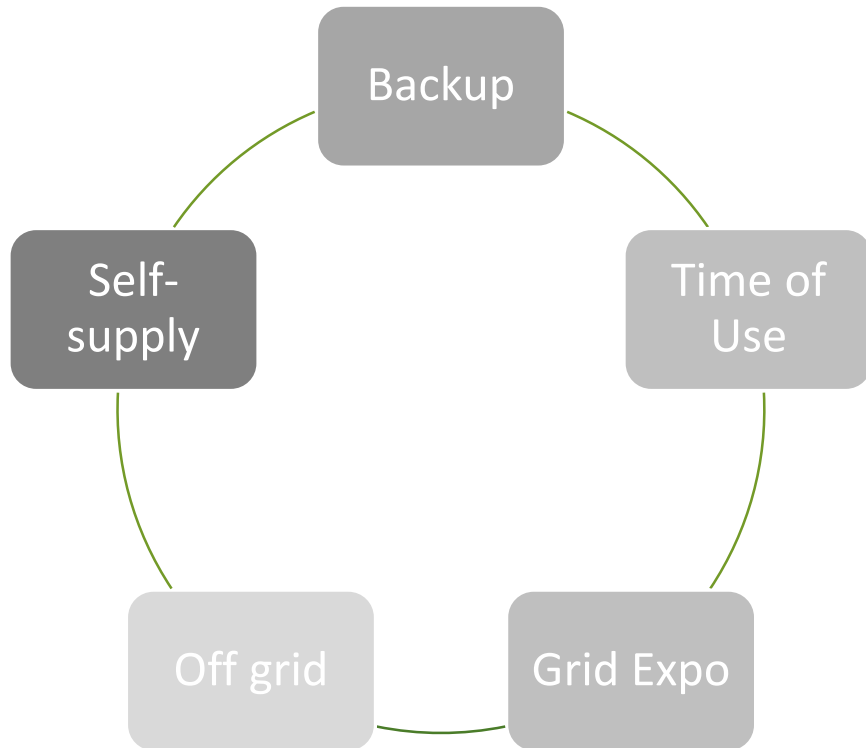

Back Up Your Facility

Power your facility when the grid is off; keep solar panels running during outages.



Maximize Your PV Production

Store excess solar power for later use.



Save Money on your Electric Bill

Charge the batteries at off-peak times; discharge them during peak periods.



Tax and Incentives

30% ITC available if it's powered by solar; enjoy state and utilities rebates



Company Introduction



Company Introduction

A world-leading manufacturer who brings automotive Lithium Ferro Phosphate batteries to the energy sector



U.S Headquarters, Southampton, PA
(30,000 Sqf)



Manufacturing Facility, Shenzhen China
(since 2008)

Fortress Lithium Battery



Lithium Ferro Phosphate Technology

We incorporate the safest technology available into our batteries.

	Fortress Power	Tesla, LG Chem, Panasonic
Chemistry	Lithium Ferro Phosphate (LFP)	Lithium Ion or Nickel- Magnesium -Cobalt (NMC)
Safety	✓	X
Eco-friendly	✓	X
Life Cycles	6000	< 3000
Operating Temperature	32– 140 °F	32 – 113 °F
Degradation Rate		LFP < NMC
Energy density		LFP < NMC

Search LFP vs. NMC nail test videos on YouTube

Lithium Ion Safety Concerns

Terrifying moment 35 firefighters struggle to tackle an enormous blaze after a Tesla Model S crashes in Austria and turns into an INFERNO

- The fire started after the 19-year-old driver crashed into a motorway barrier
- 35 crew members battled the blaze while wearing special breathing equipment
- Electric car fires are especially hard to put out because they often relight
- The battery must be cooled enough to cut the power supply



Tesla Spontaneously Catches Fire, Burns Down During Test Drive In France



by Tyler Durdan
Mon, 08/14/2016 - 10:36

0
SHARES



After Tesla's latest problem involving a Model S crash in Beijing while in autopilot mode (which has since prompted the carmaker drop remove "autopilot" from its Chinese website), Elon Musk may have to return to a more familiar problem plaguing his vehicles: spontaneous combustion.

Fortress Lithium Batteries

LFP-10 & 15



eVault 16.5



- ✓ ***Safe Lithium Chemistry***
- ✓ ***Large Capacity for Easy Installation***
- ✓ ***98% Round Trip Efficiency***
- ✓ ***Long Lasting***
- ✓ ***Competitively Priced***
- ✓ ***Lowest Cost Per Cycle***
- ✓ ***Maintenance-free***

Smart Battery Management System (BMS)

Multilevel Safety Concept for Highest Reliability

- ✓ Overcharge and Deep Discharge Protection
- ✓ Over-heat Protection
- ✓ Over Current Protection
- ✓ Cell Monitoring and Balancing
- ✓ Voltage and Temperature Monitoring



LCD Monitoring of eVault 16.5

Information on LCD Display:

- ✓ Voltage
- ✓ Current Output
- ✓ State of Charge
- ✓ State of Health
- ✓ Safety Warning: Over-charging & -discharging;
Over Current; Over-Heat
- ✓ Voltage of slave units

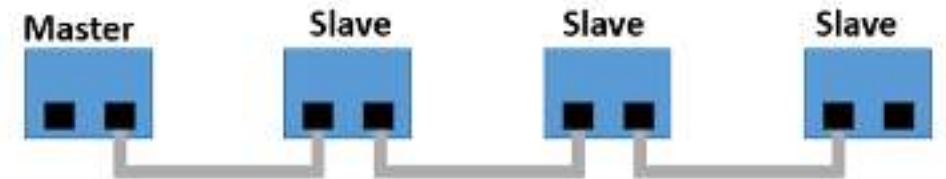

Technical Specification

	LFP-10	eVault 16.5
Total Energy [KWH]	10.2	18.4
Usable Energy [KWH]	10.2	16.5
Capacity [AH]	200	360
Battery Voltage [V]	48V	
Max. Charge Current (Continuous) [A]	80	150
Max Discharge Power (Continuous) [KW]	5 (100A)	8.2 (160A)
Peak Output [KW]	7.5 (150A)	12 (240A)
Parallel Stacking	2	8
LCD Monitoring	No	Yes
Communication	N/A	CAN/RS485
Warranty	10 years; up-to 6,000 cycles	

Compatible Inverters



AC vs DC Coupled Solution

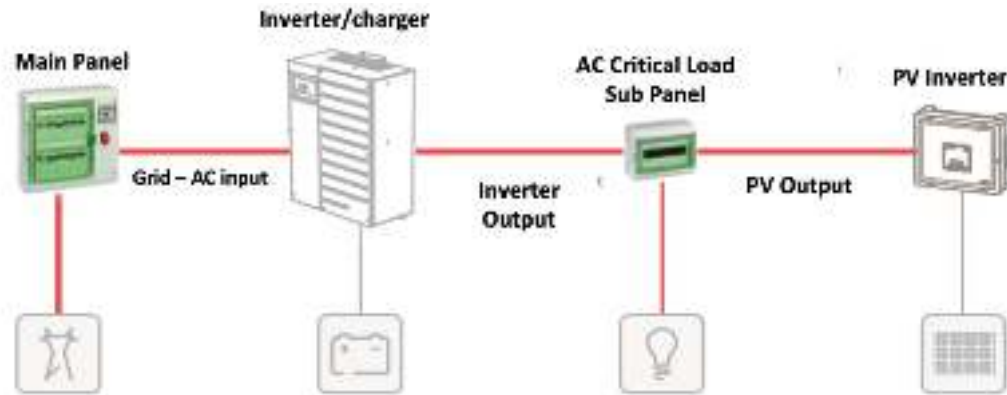

AC-Coupled System Diagram

Application for AC coupled solutions

- *When retrofitting to existing PV systems*
- *For new installations that require module level rapid shutdown*

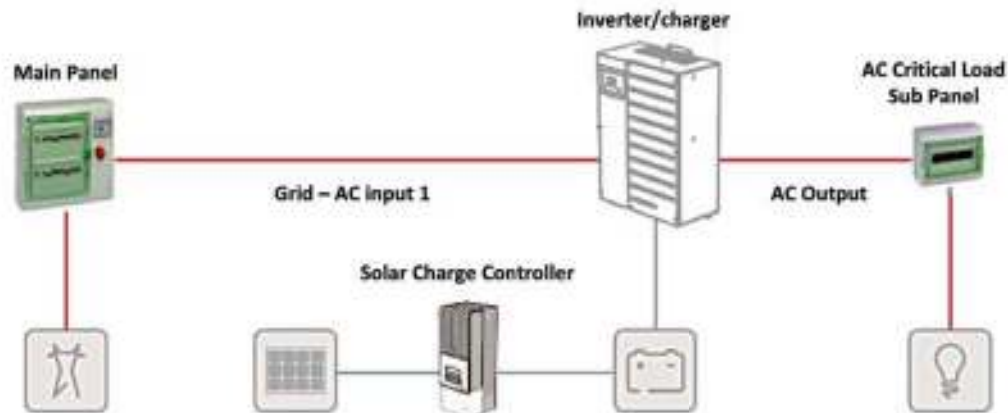

DC-Coupled System Diagram

Application for DC coupled solutions

- *For new installation*
- *No additional PV inverter*
- *More efficient*

Compatible Inverters

COMPATIBLE WITH MOST 48V CHARGERS AND HYBRID INVERTERS!

Brand	Inverter/Charger Mode	Configuration
Sol-Ark	8 KW Inverter	AC or DC coupled
Schneider	Conext XW MPPT charge controller; Conext XW+ series; Conext SW;	AC or DC coupled
Outback	Skybox, FLEX max charge controller (48V), FLEXpower series (48V); Radian series (48V); FXR(A) and FXR (E) series (48V); GVFX and GVFX series (48V);	DC coupled
Magnum	MS 4448PAE; MS 4048-20B	AC or DC coupled
SMA	SUNNY ISLAND 4548-US/6048-US; SUNNY ISLAND 3.0M/4.4M/6.0H/8.0H	AC coupled
Victron	Phoenix VE.Direct Inverter; MultiPlus and Quattro Inverter/Charger; Skylla-TG Charger; General; Color Control or Venus GX	DC coupled
Morning Star	TriStar MPPT 600V; TriStar MPPT; Tristar PWM	DC coupled
Midnite Solar	Solar Classic 150, 200 & 250; Solar Classic 150, 200 & 250-SL	DC coupled

FORTRESS + SOL-ARK 8KW (AC & DC Coupling)

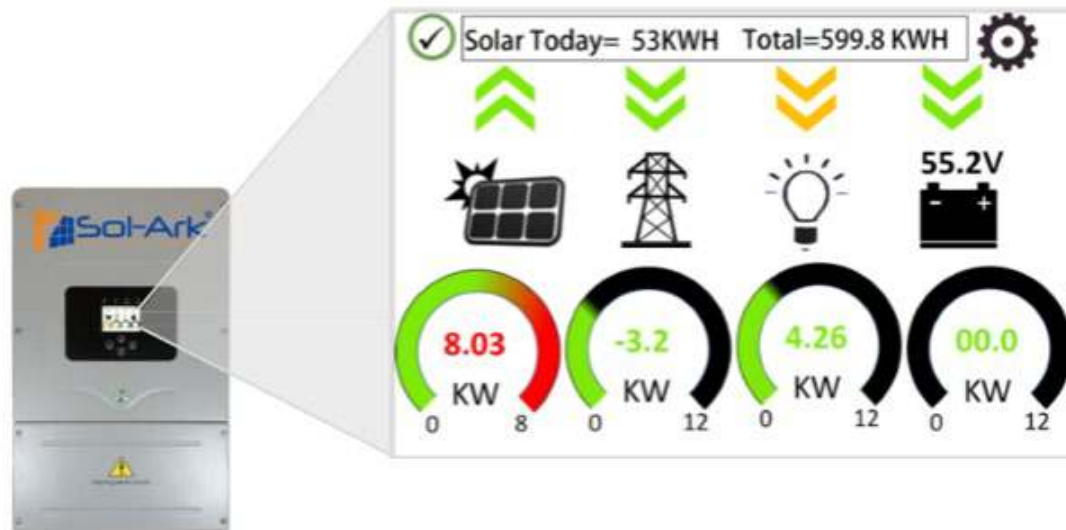

Available in our stock!

Key features:

- *All in one unit (Off-Grid; Time-of-Use; Self-Supply; Back-up; Grid export)*
- *Extreme Compact & Easy Installation*
- *DC Coupled & Transform-less*
- *The best Roundtrip efficiency: 93%*
- *High Surge Power: 20KW*
- *Auto-Gen Start included*
- *Allows to use Gen Output to AC couple to an existing PV array*

Technical Specification

	Output to the Critical Load		Output to the Grid
	On Solar or Battery (Back-up)	With Grid or Generator Present	Pass-through
AC Output Power	8 KW	12 KW	12 KW
Surge power	20 kW (5 Sec)		
AC Output Voltage	120/240V & 120/208V		
UPS Grid Failure Transfer time	12 kW auto-transfer relay at 2ms		
PV Array in DC Coupling	Up-to 11 KW		
PV Array in AC Coupling	Up-to 7 KW		
PV Array in AC & DC Coupling combined	Total max 13 KW		
Module-level rapid shutdown Compliance	Adding Tigo Optimizers		
Storage capacity	10/16.5 KWH per unit; scalable to 132 KWH		

Fortress + Schneider XW+ (AC & DC Coupling)

Key features:

- *Over 10 years in operation*
- *All in one unit (Off-Grid; Time-of-Use; Load shifting; Back-up; Grid export)*
- *Allows DC & AC coupling*
- *Single or three phase systems from 7 kW to 102 kW*
- *Performs in hot environments up to 70°C*
- *Auto-Gen Start optional*



Technical Specification

	Technical Specification	
Inverter AC output	5.5 KW	6.8 KW
Surge power at backup	7/9.5 kW (30 min/60 sec)	8.5/12 kW (30 min/60 sec)
Storage capacity	10/16.5 KWH per unit; scalable to 132 KWH	
UPS Grid Failure Transfer time	Built-in 60A auto-transfer relay at 8ms	
Compatible PV Inverters	AC-coupled to Enphase, AC modules, Solaredge, SMA, Fronius 10 kW+, etc.	
Stack-ability	<ul style="list-style-type: none"> ▪ Max. 4 in 1-Ph (120/240V) ▪ Max. 9 in 3-Ph (120/208V): 3 units per phase 	
Requirement	<ul style="list-style-type: none"> ▪ PV Watts \leq XW+ Max Continuous AC output ▪ PV Watts /48V = PV array's Max Charging Current \leq Battery Max Charging Current ** 	

**Example: 7.5 KW PV array /48V = 156 A



6.8 kW/30 kWh ESS

Integrating Midnite for String Level Rapid Shutdown

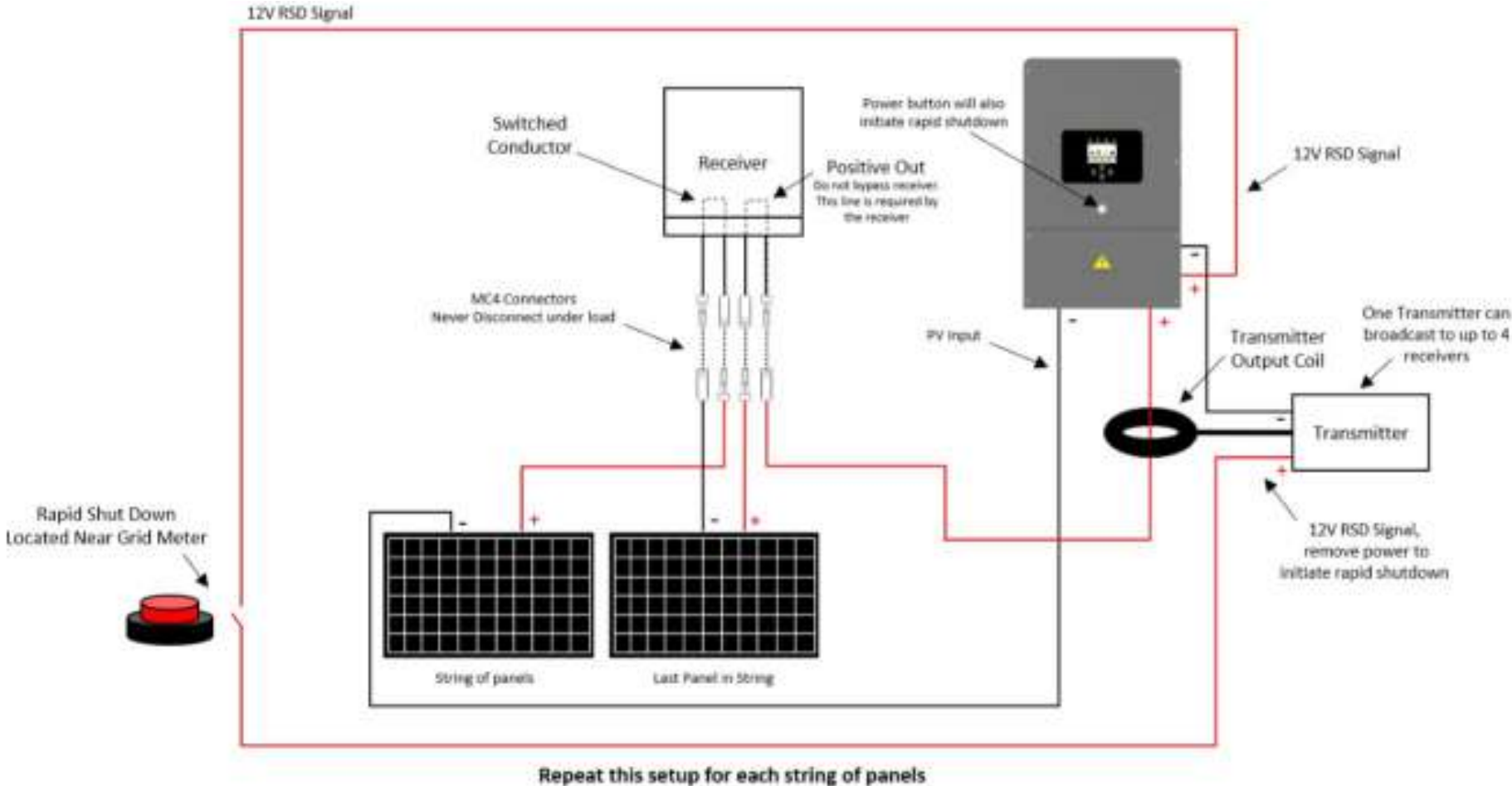

Integrating Tigo for Module Level Rapid Shutdown

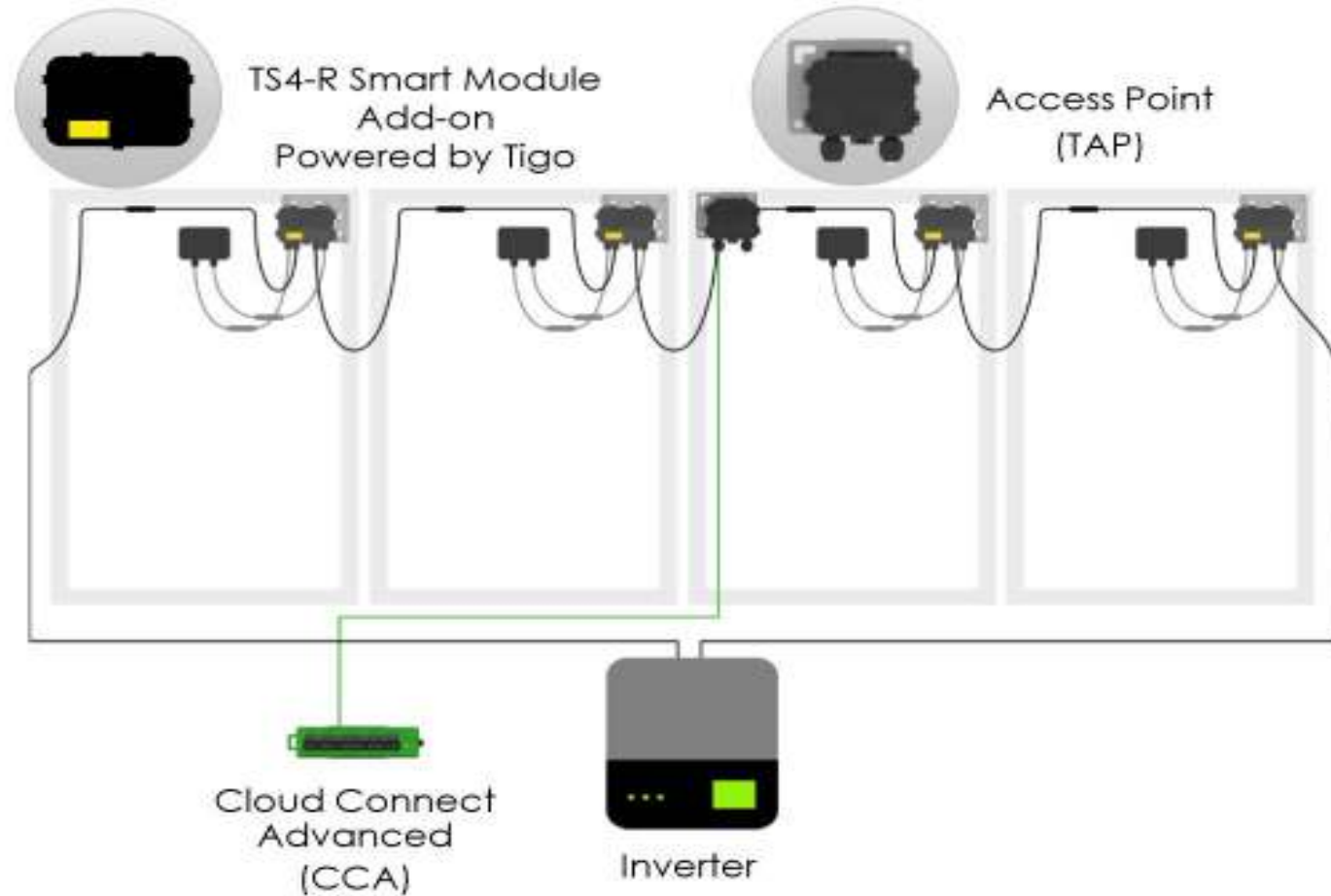

Integration Guide



Fortress LFP Battery Charging Curve

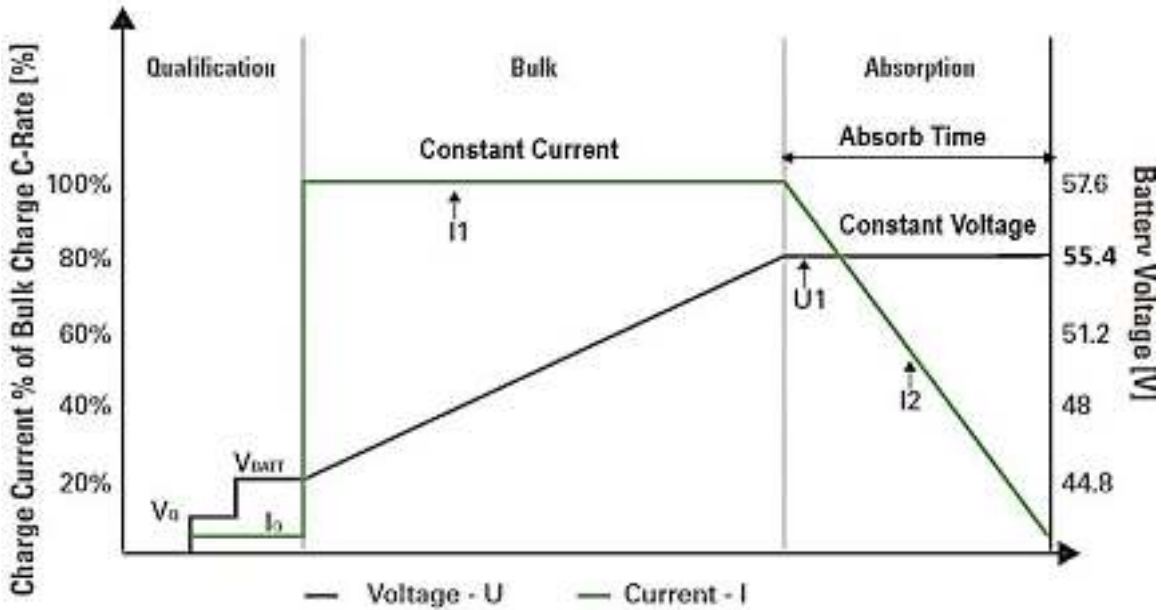

	Lithium Ferro Phosphate (LFP)	Lead Acid
Absorb time	6 min	120min
Float Charge	N/A	✓

Integration Guide-Inverters/Charger Setting

Charger/Inverter configuration recommendation for best performance:

	3000 Cycles	6000 Cycles
Equalized Support	Off	Off
Capacity Limit	LFP-10: 200Ah / 16.5: 360Ah	
Equalized Voltage	Off	Off
Recharge Voltage	47V	49V
Bulk Voltage	57.6V	55.4V
Absorb Voltage	57.6V	55.4V
Low Battery Cut Out Voltage	48.4V (48V)	50.7V (48V)
High Battery Cut Out Voltage	58V	56 V
Float Voltage	OFF/unless use as back up (54.4V)	
Max Charge Current	LFP-10: 80A per battery eVault 16.5: 150A per battery	LFP-10: 50A per battery eVault 16.5: 100A per battery

The Battery Parameter Setting Guides with Schneider, Outback and SMA inverters are available to download on www.fortresspower.com/Resource

Temperature Impact on Performance

Discharge Voltage of LFP in Relation to Temperature
@ 0.5C discharge rate

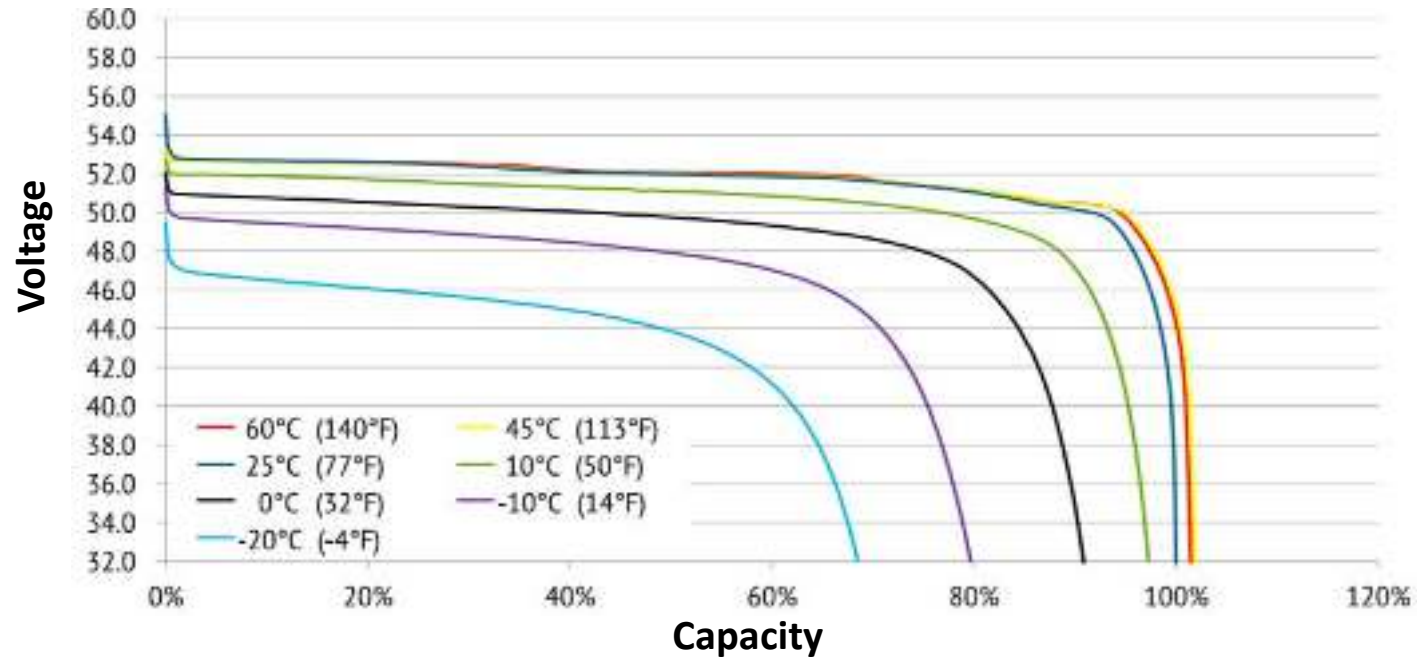

	3000 Cycles	6000 Cycles
Temperature Range	32 F to 130F (0 °C to 49°C)	10 F to 110 F (0°C to 43°C)

Cycle Life vs Depth of Discharge

Cycle Life in Relation to Depth of Discharge (DoD)
@ 0.5C charge/discharge

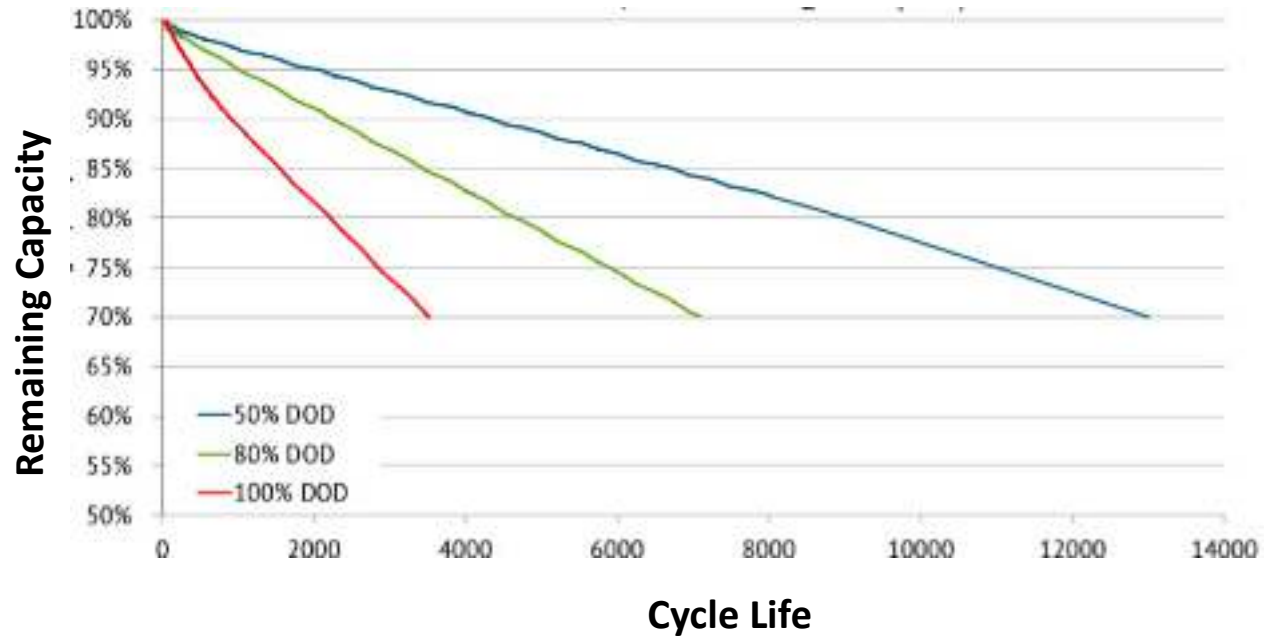

	3000 Cycles	6000 Cycles
Depth of Discharge	90%	80%



Battery Technology Comparison

Comparison of different Battery Technologies

	Fortress LFP	Lithium Ion	Li-Polymer	Flooded LA*	AGM*	Carbon AGM*	Nickel Iron*
Round trip efficiency	98%	95%	95%	80%	88%	94%	65%
Cost of 10 kWh Usable Power (MSRP)	6,900	6,999	4,500	2,800	3,600	5,000	18,000
Cycle Life	6,000	2,500	1,500	600	750	2,400	8,000
Off Grid Years	16.4	6.8	4	2.7	2	6.5	21.9
Cost per Cycle per kWh	0.11	0.28	0.30	0.46	0.48	0.21	0.23
Safety	Yes	No	No	No	No	No	Yes
Free Maintenance	Yes	Yes	Yes	No	Yes	Yes	No

* Lead Acid, AGM, Carbon AGM and Nickel Iron can only be discharged to 50%; additional battery rack is required!

30% ITC only applies to the first install!

Comparison Chart of Various Lithium Batteries

	Fortress Power	Simpliphi	Discover	LG Chem	Panasonic
Battery Chemistry	LFP	LFP	LFP	NMC	NMC
Safety	Y	Y	Y	N	N
Usable Power	10/15/16.5 kWh	2.5/3.5 kWh	6.6 kWh	9.3 kWh	2 kWh
Roundtrip efficiency	98%	98%	98%	94.5%	96.5%
LCD Display	Yes	No	No	No	No
Guaranteed Battery Cycles	6,000	10,000	5,000	2,500	2,800
Off-Grid years	16	27 **	13.6	6.8	7.7
Price per kWh	Low	High	High	Low	Low
Installation time	Low	High	High	Low	High
Cost per Cycle	Lowest	Mid	Mid	High	High

** Simpliphi uses low-cost MOSFET based BMS, which only lasts 10-15 years.

Performance Comparison

LFP vs Lead Acid at various discharge rate

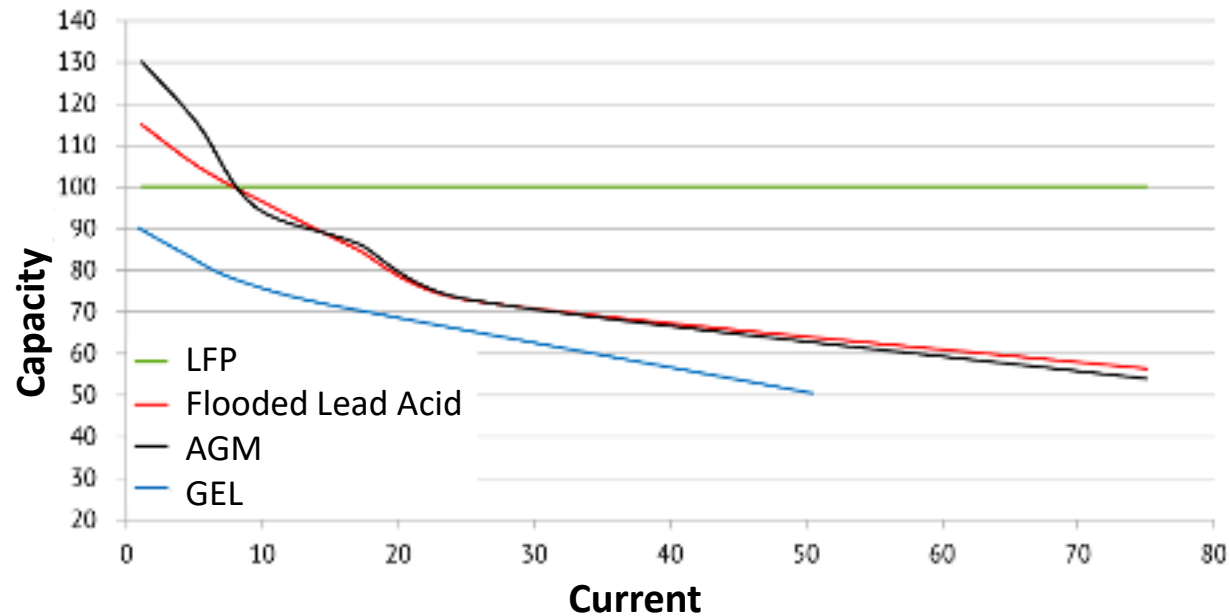

Disadvantages of Lead Acid:

- *Capacity drops significantly when output current increases*
- *6 times more space*
- *Higher cable cost and longer installation time*

Performance Comparison



**48V, 240AH
AGM Battery**



Fortress Storage Sizing Tool

Fortress Energy Storage Sizing Tool

4 Steps to Size Up Energy Storage for Backup

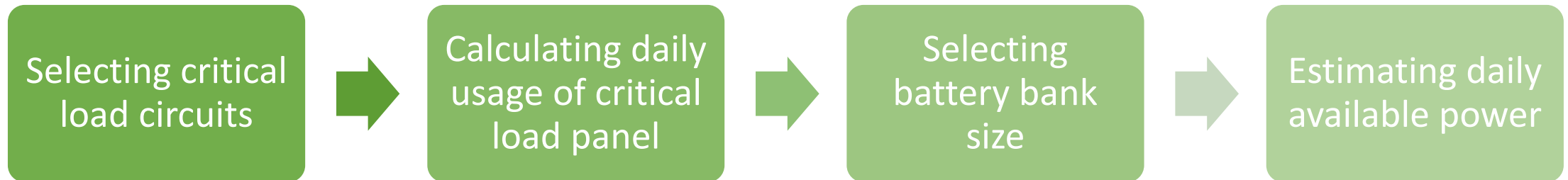

***Installation
Guide***



Installation Guide

How to Select Cables

Maximum Ampacities for Wire and Cable				
Wire Size (AWG)	Copper Conductor Temp. Rating		Aluminum Conductor Temp. Rating	
14*	20A	25A		
12*	25A	30A	20A	25A
10*	35A	40A	30A	35A
8	50A	55A	40A	45A
6	65A	75A	50A	60A
4	85A	95A	65A	75A
2	115A	130A	90A	100A
1	130A	150A	100A	115A
1/0	150A	170A	120A	135A
2/0	175A	195A	135A	150A
3/0	200A	225A	155A	175A
4/0	230A	260A	180A	205A



M8 Terminal Ring
(diameter:8mm or 5/16 inches)



knockouts
3/4, 1 & 1 1/4 inch

How to Parallel Fortress Batteries

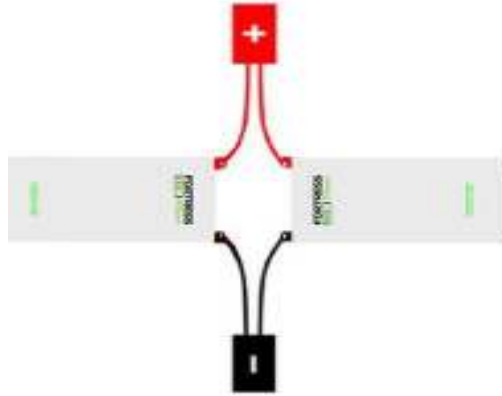

- Common Bus is recommend!
- Please do not cross the positive and negative terminals
- Use a volt meter to check polarity before connecting terminals.
- Measure voltage and make sure difference is less than 0.5V before turn on
- During installation breaker on “OFF” position

How to Parallel eVault 16.5



RS 485 cable

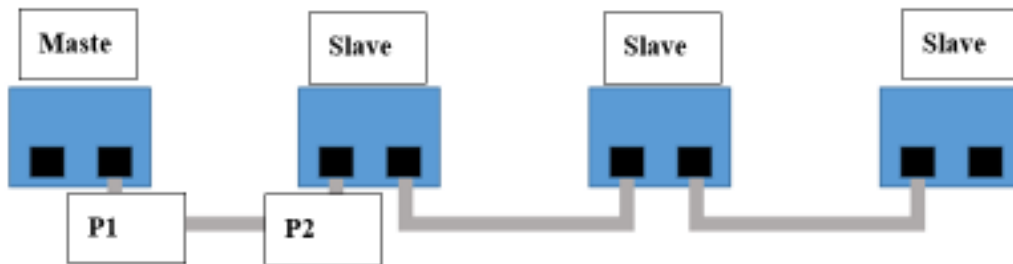

1. Push “M-Set”, set the first battery pack as “Master.”
2. Push Parallel number: put how may battery you put in parallel in the system. For example, 3 batteries should be.
3. Check the voltage of slave units on the Master’s Screen
4. You should hear relay start connecting battery to the system, check each battery status.

Authorized Installer Benefits

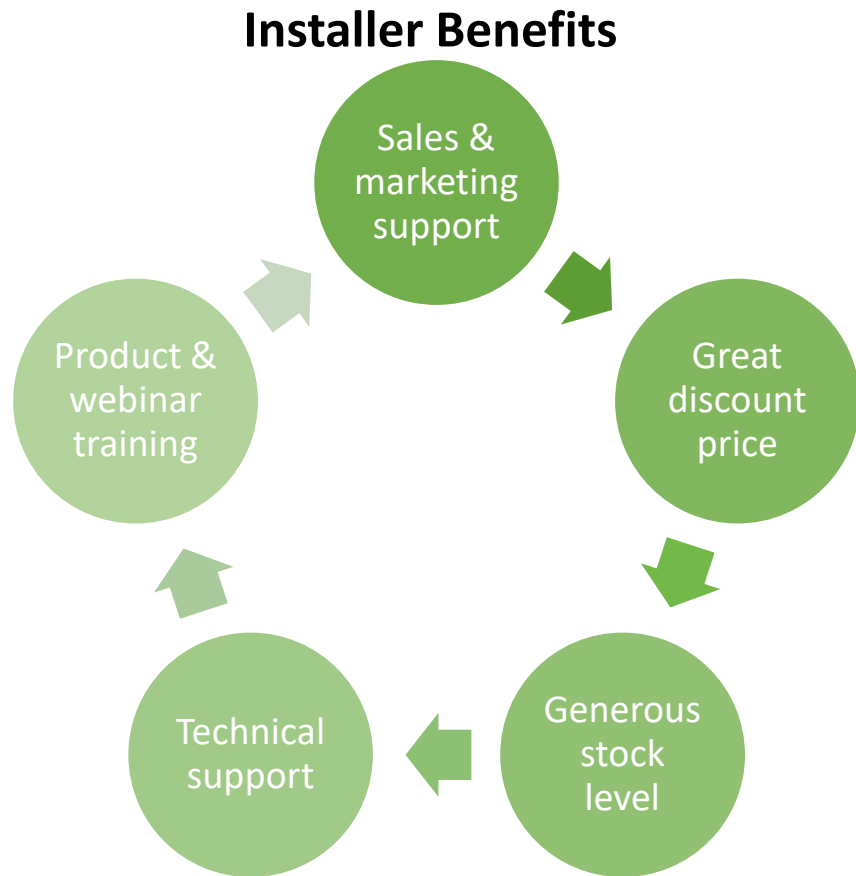

Becoming

Fortress Power
Authorized Installer



Our Product Advantages



- ✓ **Safe**
- ✓ **Competitively priced**
- ✓ **Lowest cost per cycle**
- ✓ **Long lasting**
- ✓ **Best round-trip efficiency**
- ✓ **Easy installation**
- ✓ **Maintenance-free**



Thank You & Contact Us



Alex Lepore
alexl@fortresspower.com
(877) 497- 6937
www.fortresspower.com