

# Sol-Ark 8K Install Guide Owner's Manual

## INSTALL GUIDE 1-24

---

TABLE OF CONTENTS	1
DISCLAIMER	2
COMPONENT GUIDE	3
SYSTEM PLACEMENT	4
TRANSFER SWITCH	5
MOUNTING	6
BATTERY WIRING	7-8
SOLAR PANEL WIRING	9-10
SYSTEM WIRE DIAGRAM	11
LARGE GENERATOR DIAGRAM	12
BACKUP GAS GENERATOR SETUP	13
SENSOR PLACEMENT & TESTING	13
BATTERY SETTINGS AND <u>WIFI SETUP</u>	14-20
EMP SUPPRESSOR INSTALLATION	20
RAPID SHUTDOWN DIAGRAM	21
SPECIFICATIONS	22
HOW TO UPGRADE FROM SOL-ARK 3K	23
OFF GRID TIPS	24
GRID TIE / NO BATT TIPS	24

## OWNER'S MANUAL 25-39

---

POWERING ON THE SYSTEM / INDICATOR LEDs	25
SELECTING POWER MODES / SENSORS	25-26
BATTERY SETTING / WIFI SETUP	27
SCREENS	28-32
BATTERY CHARGE/DISCHARGE REFERENCE	33
WARRANTY	34
TROUBLESHOOTING GUIDE / ERROR CODES	35-37
INSTALL TESTING CHECKLIST	38-39

## CONTACT US

PHONE	1-972-575-8875
EMAIL	SALES@SOL-ARK.COM
WEBSITE	WWW.SOL-ARK.COM



## Disclaimer

UNLESS SPECIFICALLY AGREED TO IN WRITING, SOL-ARK:

(a) MAKES NO WARRANTY AS TO THE ACCURACY, SUFFICIENCY OR SUITABILITY OF ANY TECHNICAL OR OTHER INFORMATION PROVIDED IN ITS MANUALS OR OTHER DOCUMENTATION.

(b) ASSUMES NO RESPONSIBILITY OR LIABILITY FOR LOSS OR DAMAGE, WHETHER DIRECT, INDIRECT, CONSEQUENTIAL OR INCIDENTAL, WHICH MIGHT ARISE OUT OF THE USE OF SUCH INFORMATION. THE USE OF ANY SUCH INFORMATION WILL BE ENTIRELY AT THE USER'S RISK.

Sol-Ark cannot be responsible for system failure, damages, or injury resulting from improper installation of their products.

Information included in this manual is subject to change without notice.

Sol-Ark 8K inverter should be installed by qualified persons only.



**Do Not Mount Outdoors**  
**Do Not Expose to Moisture**  
**System Must Have Ground**  
**System Must Have Neutral**  
**Solar Panels Are Ungrounded**  
**Ground Must be Bonded to**  
**Neutral Once in Home**

## 1. Inspect Shipment

- a. Compare the package condition to the condition of the package in the photo we sent you before it left our facility. **You must note any damage to shipping with delivery driver before accepting the package otherwise the shipping company will deny any claim.**
- b. If damaged, contact us immediately at 972-575-8875 Ext. 3

## 2. Component Guide

- a. Solar Panel MC4 tool: To disconnect solar panels
- b. Battery Resistor: To connect batteries for the first time
- c. WIFI Plug: For software updates and remote monitoring (You will receive one or the other WIFI plug, not both, picture indicates what the plugs look like)
- d. Limiter Sensors: for Limited to Home Mode or Full Grid Sell w/ standby generator
- e. French Cleat: For wall Mounting the Sol-Ark 8K
- f. Battery Temperature Sensor: For voltage adjustment
- g. Battery Cables (If Purchased)
- h. Solar Panel Wire 100' (If Purchased)
- i. Solar Panel Jumper wires 25' (If Purchased)
- j. Y-Connectors (If Purchased)
- k. Battery Toroid: For EMI reduction



### 3. Component Distance Guide

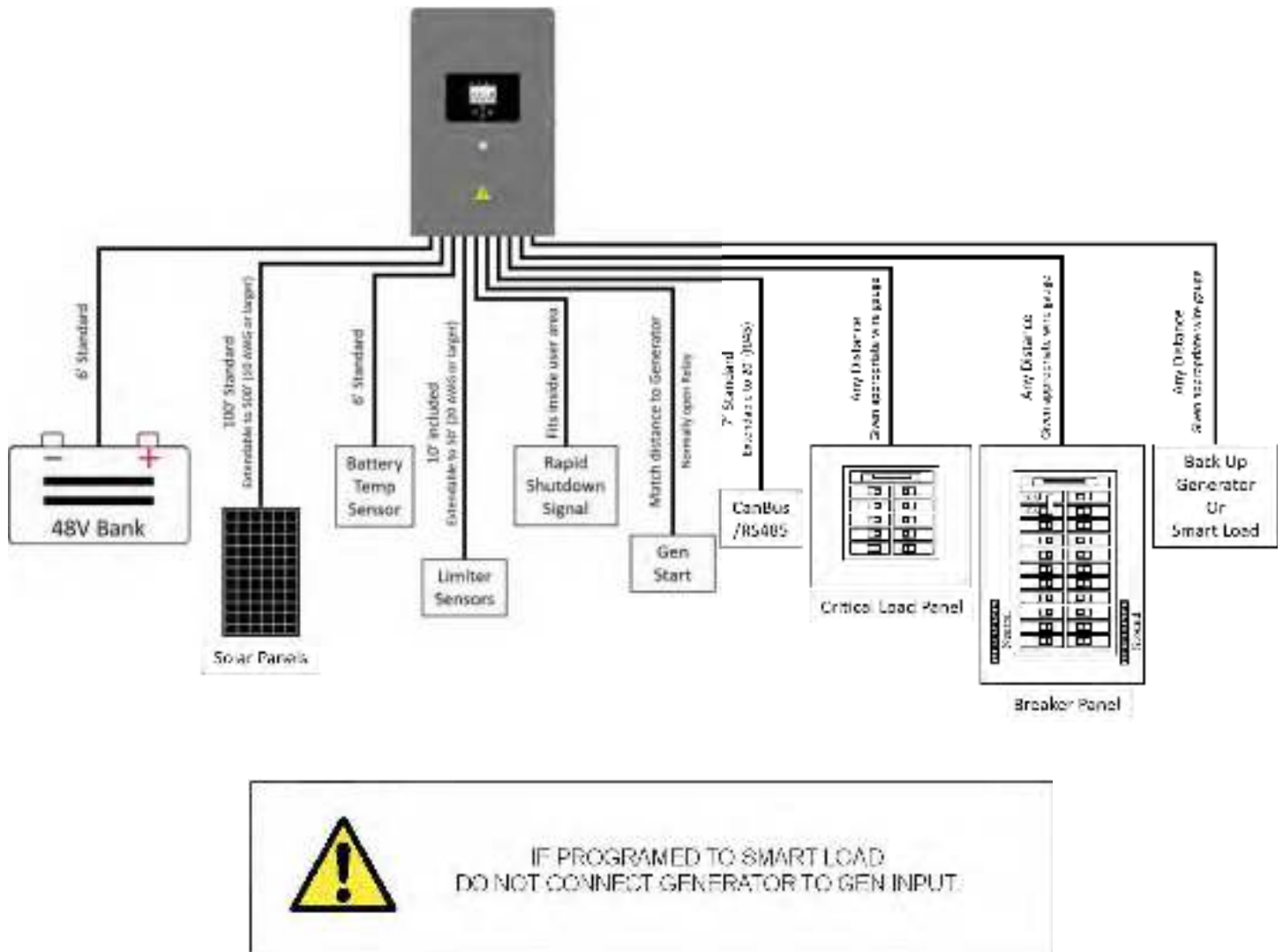

### 4. Decide Critical Backup Circuits

- a. Decide which 10 circuits will be on backup power continuously. These circuits **must use non-GFI breakers** to work with this Transfer Switch. You can replace a GFI breaker with normal breaker and install GFI outlets instead (or you can move GFI breaker into 10-circuit SW). Sometimes low load circuits can be combined.
- b. Keep well within limits of inverter. On Grid = 50A continuous. Off Grid = 33A continuous/83A peak.
- c. Verify each load circuit by measuring typical and max Amps with a clip-on Amp meter. Amps x 120V = Watts

## 5. Count Transfer Switch

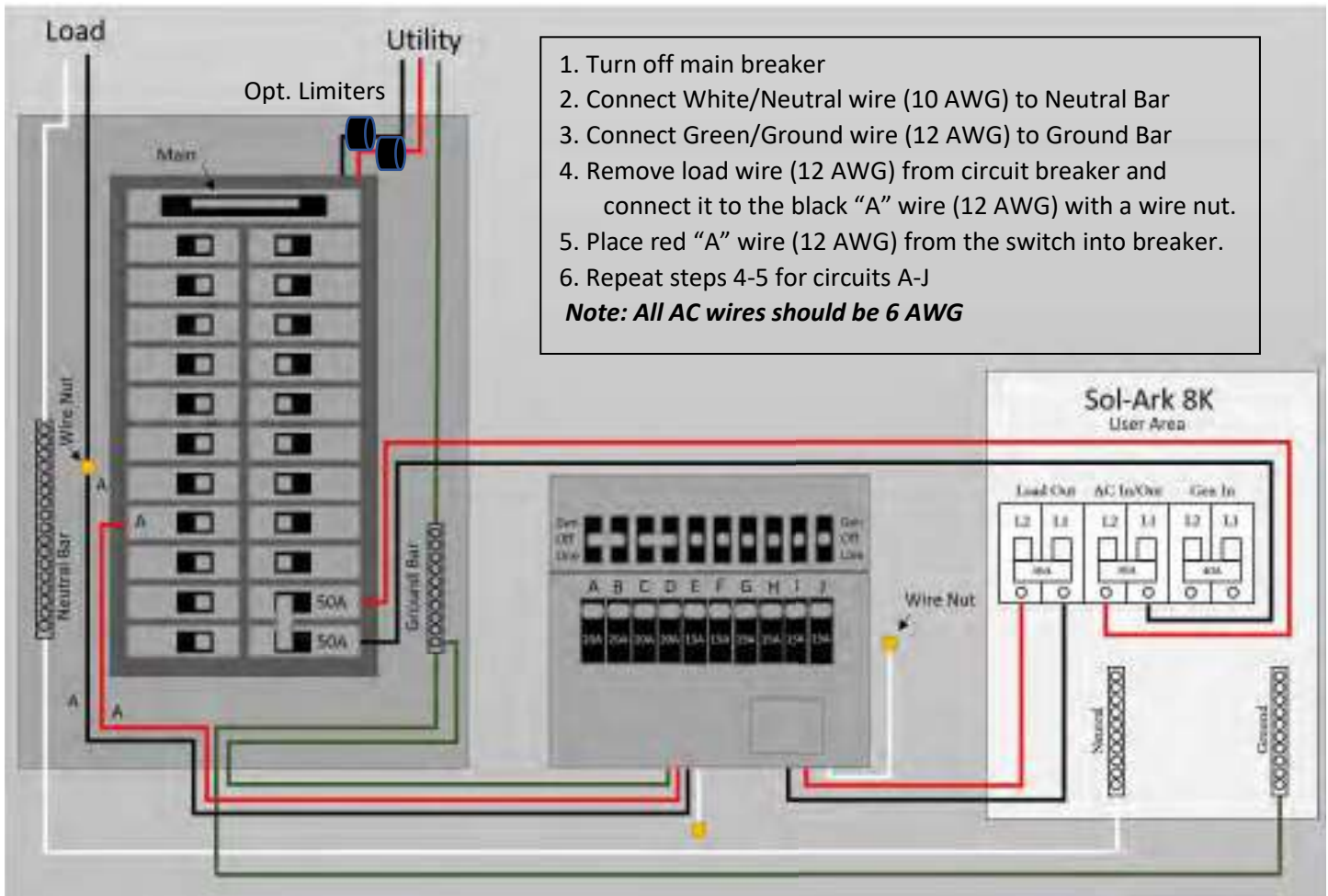

This is designed to allow you to distribute critical power using your house wiring. It is 3X faster than wiring a new sub-load panel. When the switch is in the “Gen” position, that circuit is powered by the Sol-Ark (which can use Grid/Solar/Battery/Generator automatically); in the “Line” position it is powered by the grid (Sol-Ark can be removed). Once you set all the switches to Gen position, leave it forever and the Sol-Ark will take care of the rest.

If you are not installing a transfer switch (Off Grid or have a 50A sub-load panel), you can wire the “Load” output of the Sol-Ark 8K directly to a Main Lug breakers sub-panel rated for at least 50A.

**Please refer to page 11 for complete wire diagram**

### **Important Notes:**

**Strain Reliefs must be used for all wires going in/out of the Sol-Ark 8K user area**

**Ground and Neutral must be wired as shown above, or damage will occur.**

**Conduit (or double insulated wire) must be used for the AC Wires going to and from the Sol-Ark**

**DO NOT CONNECT THE GRID TO THE LOAD OUTPUT BREAKER**

**6. Install Double Pole 50A breaker in Main panel for Grid in/out**

- a. It is best practice to Install at the opposite end of the bus bar from the main breaker (Usually this is the bottom of the breaker panel as seen on page 5).

**7. Mount Sol-Ark 8K**

- a. Find a suitable location for the system, keeping in mind the dimensions shown here.
- b. System must be protected from moisture and extreme heat. (**do not mount outdoors or in attic**)
- c. The system weighs 75lbs (34kg), be sure to attach it securely to the wall. You may need to affix a mounting board to your wall first using 6-8 screws into studs.
- d. Then use 2-3 screws (appropriate in length and type for your mounting surface) to mount the French Cleat to the board/wall. (Washers recommended)
- e. Mount the Sol-Ark on the installed Cleat making sure that it seats properly and is level.
- f. Add 2 screws in bottom mounts

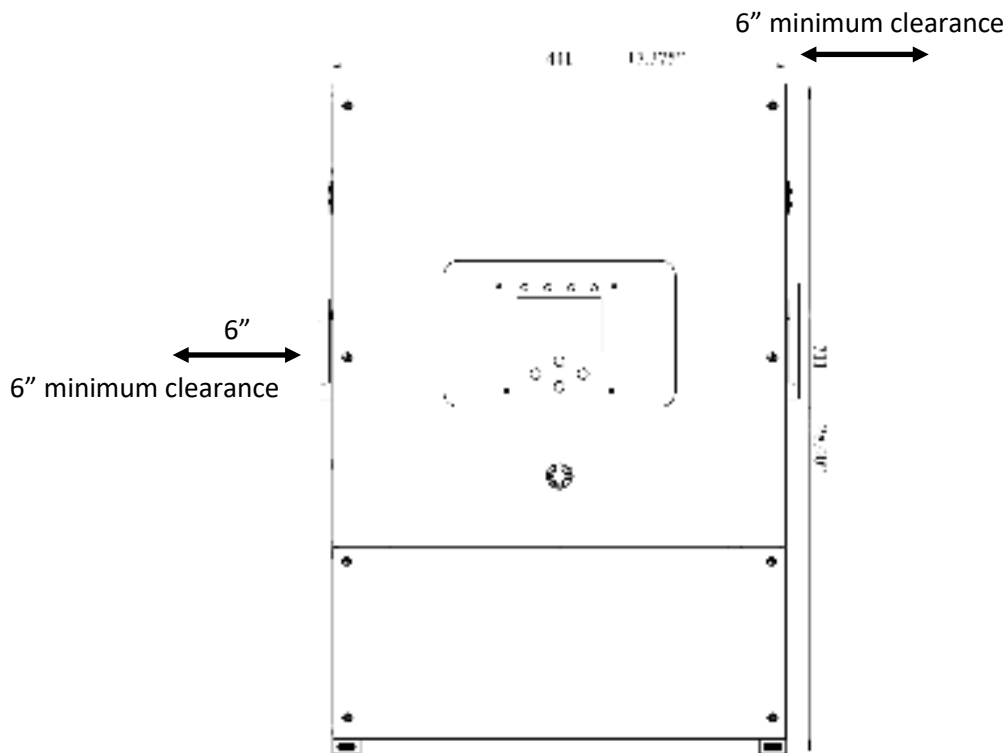

**8. Connect Batteries (Sol-Ark should be off)**

- a. Connect the batteries to the Sol-Ark 8K as shown in the diagrams below
- b. Install included ferrite on the battery input cables. Slide the ferrite over the battery cables so that both cables are within the toroid (as shown here).
  - i. The toroid usually fits inside the user area of the Sol-Ark.
- c. When connecting for 1<sup>st</sup> time, use included 100ohm resistor to pre-charge the inverter for 30s before connecting 6ft cable to Sol-Ark.
  - i. Hold the resistor so that it contacts the free battery cable and the battery terminal, completing the circuit (see below). This can be done with small clamps or by hand.

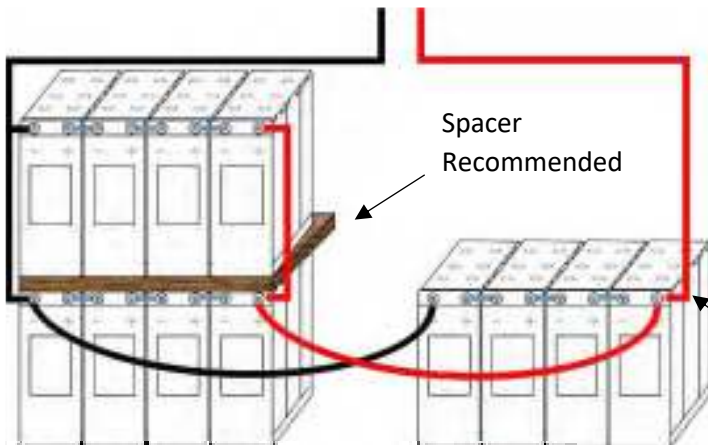

Sol-Ark 8K is a **48V** system. Do not wire the battery bank to any other nominal voltage. When using 12V batteries do not exceed 4 batteries in series. When using other battery chemistries, stay within the voltage range: Min 41V-Max 59V

*Note: PCC batteries are stackable (max 2 high)*

**Do not Reverse Polarity of Batteries or damage will occur.**

Use Included Resistor to Charge Capacitors When Connecting Batteries for the first time. Hold for 30 Seconds.

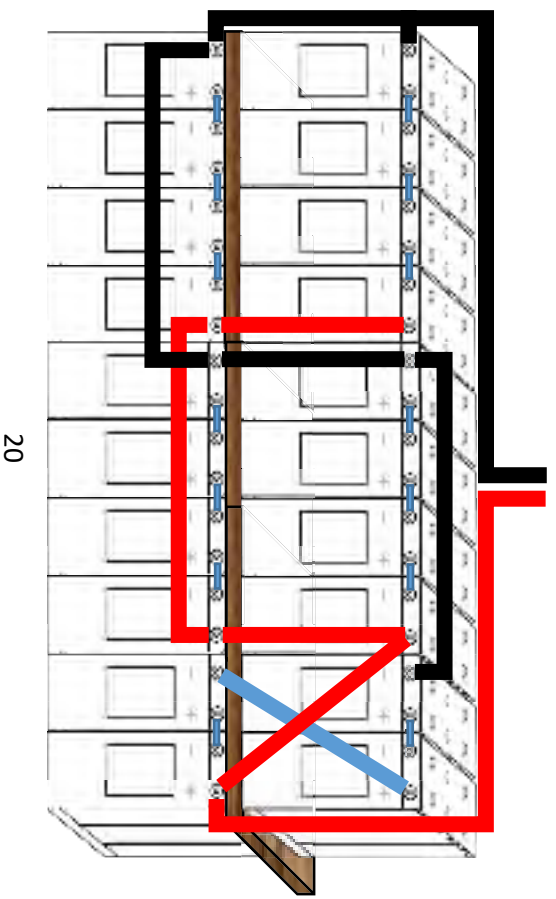
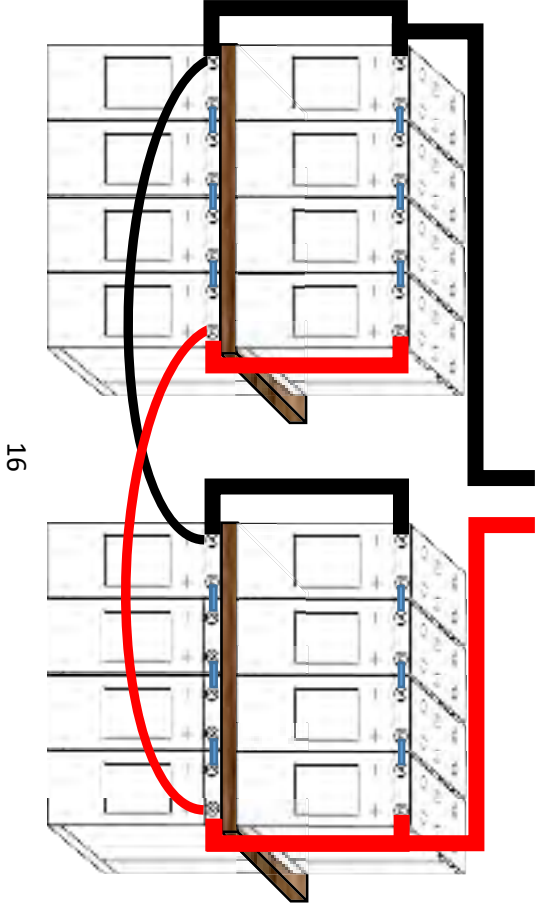
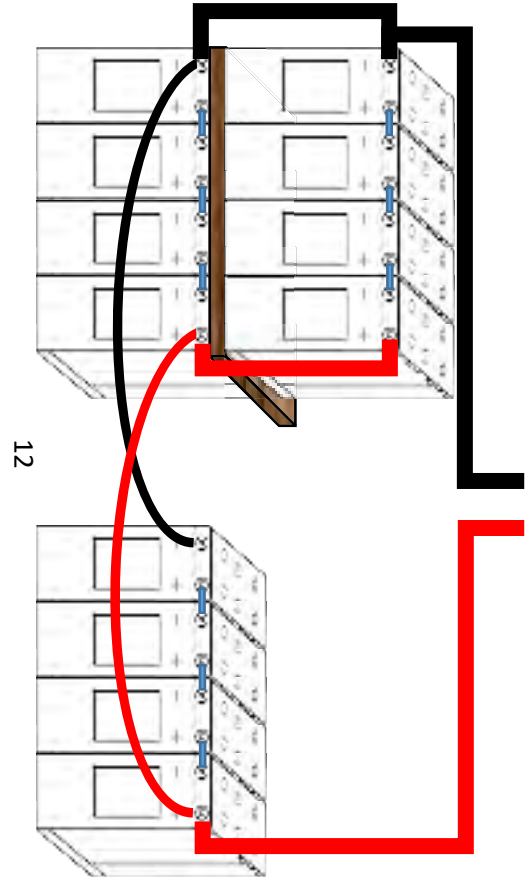
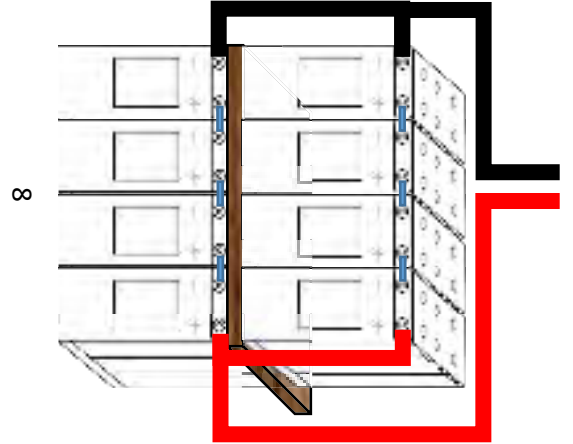
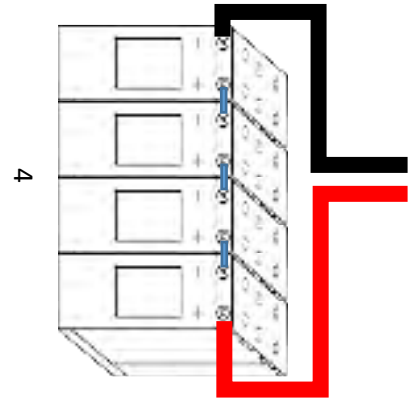

## 9. Solar Panel Install

- Sol-Ark 8K has 2 separate pairs of solar panel inputs.  
(Dual MPPT)
- Use the chart to the right to determine how many strings of panels and how many panels per string can be installed. This chart is only a guide, other panel types and configurations can be compatible if within the specs of the system.
- Max PV input:  
11,000W(+/- 5%) per system (6,000W per MPPT) PV = 500Voc Max  
Note: Damage will occur if PV > 550V
- Connect the strings of solar panels to the system as shown on pages 9/10.
- Each pair of strings, PV1A/B and PV2A/B, must be the same voltage if both are used (see chart).
- Panel frame grounding can be done to any ground in the home via 12AWG wire. Mounts usually bond frames together, so only 1 ground wire is needed.

## Suggested Solar Panel String Guide (60 or 72 cell Panels, 305W/Panel or less)

Total Panels	PV1A	PV1B	PV2A	PV2B
1	N/A	N/A	N/A	N/A
2	N/A	N/A	N/A	N/A
3	N/A	N/A	N/A	N/A
4	N/A	N/A	N/A	N/A
5	5	N/A	N/A	N/A
6	6	N/A	N/A	N/A
7	7	N/A	N/A	N/A
8	8	N/A	N/A	N/A
9	9	N/A	N/A	N/A
10	5	5	N/A	N/A
11	6	N/A	5	N/A
12	6	6	N/A	N/A
13	7	N/A	6	N/A
14	7	7	N/A	N/A
15	8	N/A	7	N/A
16	8	8	N/A	N/A
17	9	N/A	8	N/A
18	9	9	N/A	N/A
19	6	6	7	N/A
20	7	7	6	N/A
21	7	7	7	N/A
22	7	7	8	N/A
23	8	8	7	N/A
24	8	8	8	N/A
25	8	8	9	N/A
26	9	9	8	N/A
27	9	9	9	N/A
28	7	7	7	7
29	N/A	N/A	N/A	N/A
30	8	8	7	7
31	N/A	N/A	N/A	N/A
32	8	8	8	8
33	N/A	N/A	N/A	N/A
34	9	9	8	8
35	N/A	N/A	N/A	N/A
36	9	9	9	9

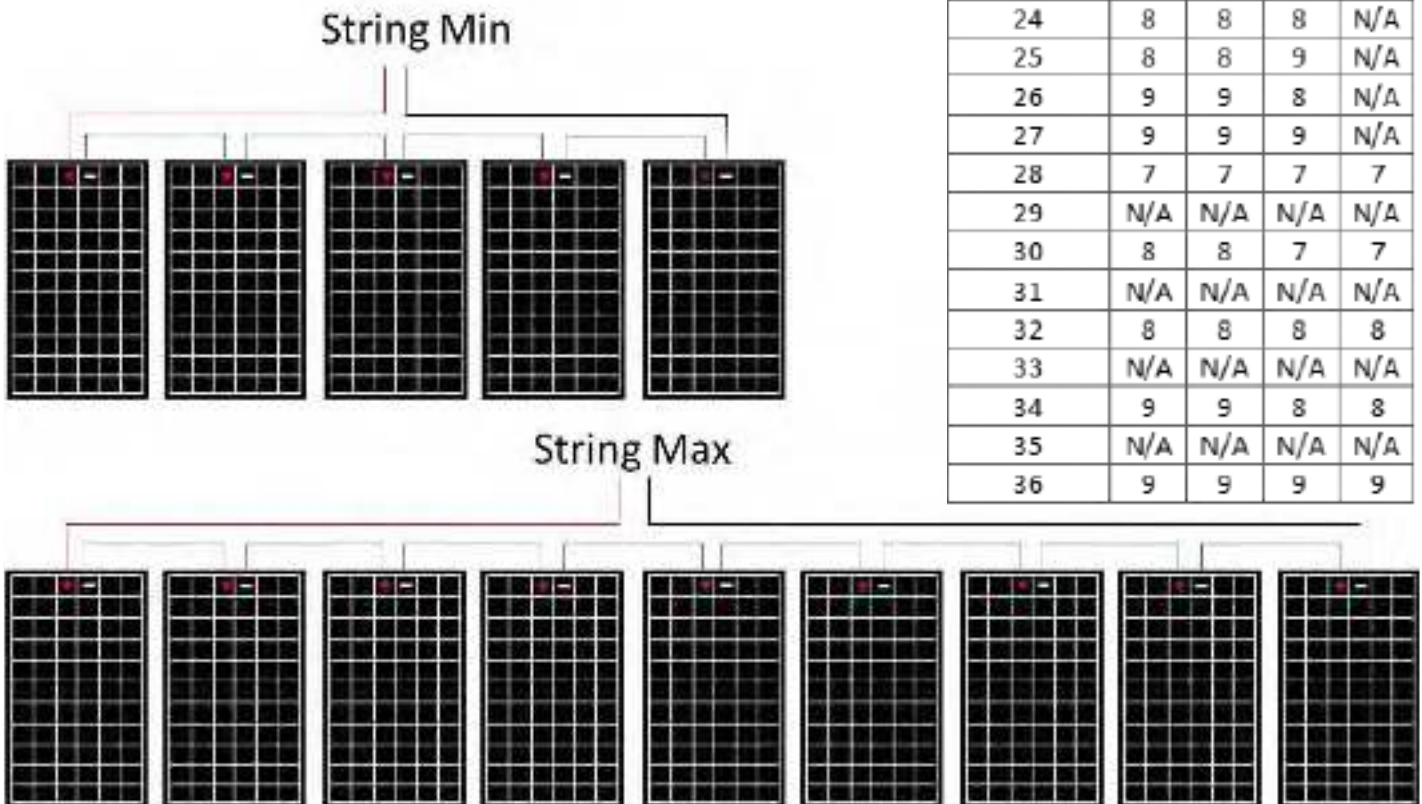

**If Y-Connectors:** (Note: separate wires can be used per string, and string minimum is 5 panels or 175V)

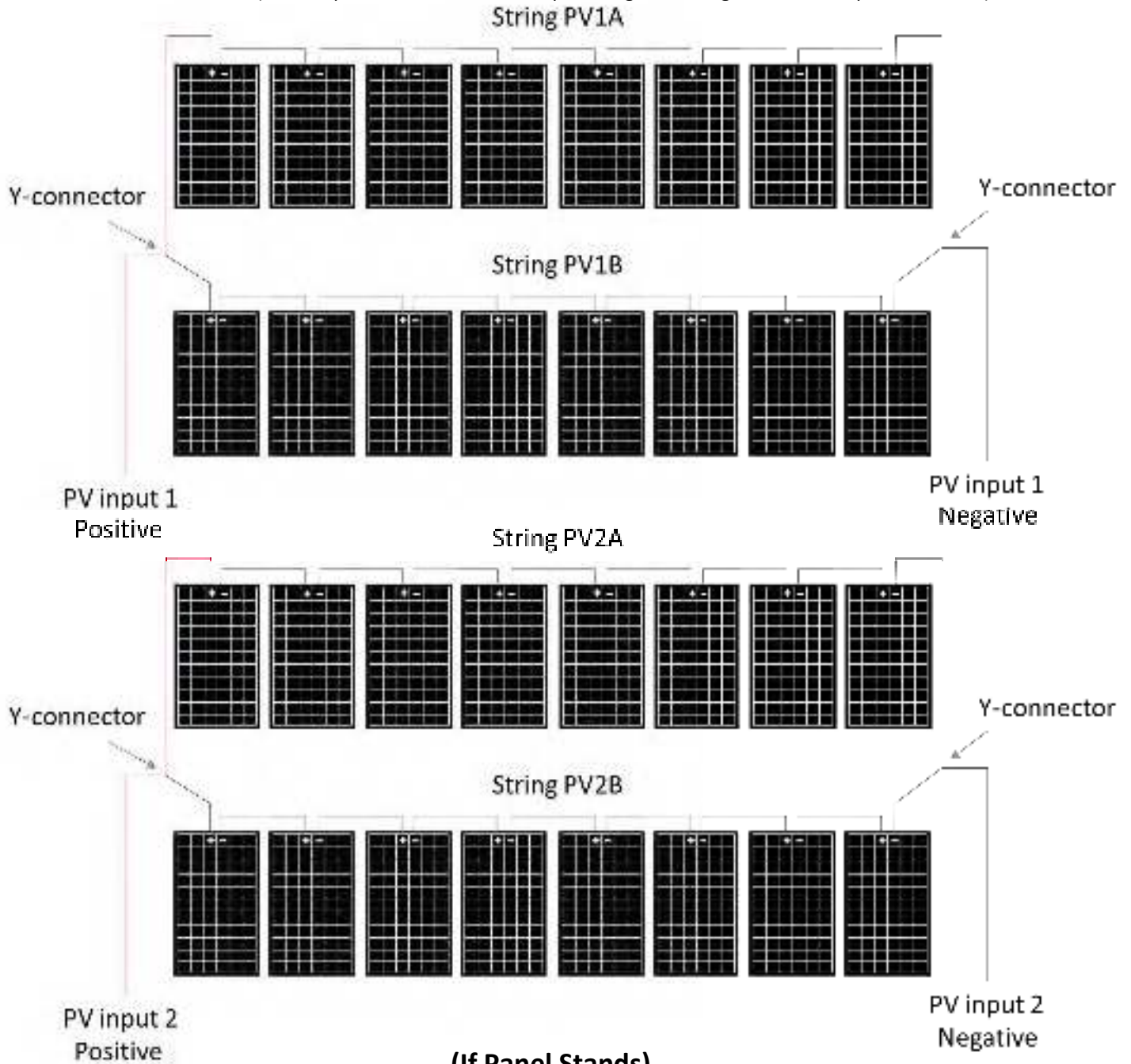

**(If Panel Stands)**

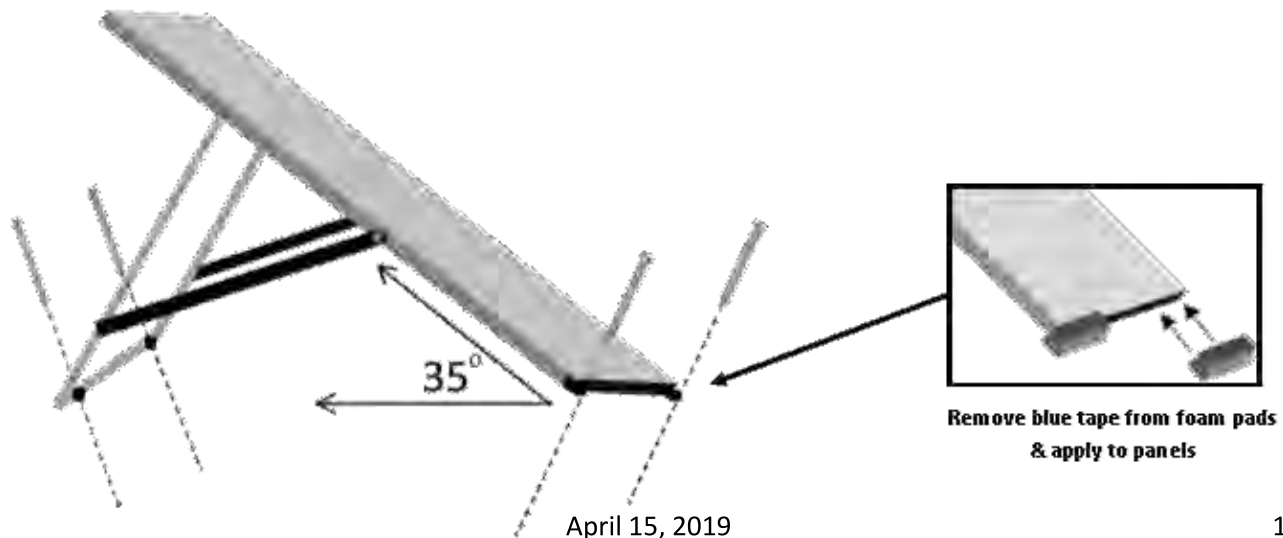

# <10KW Generator Diagram

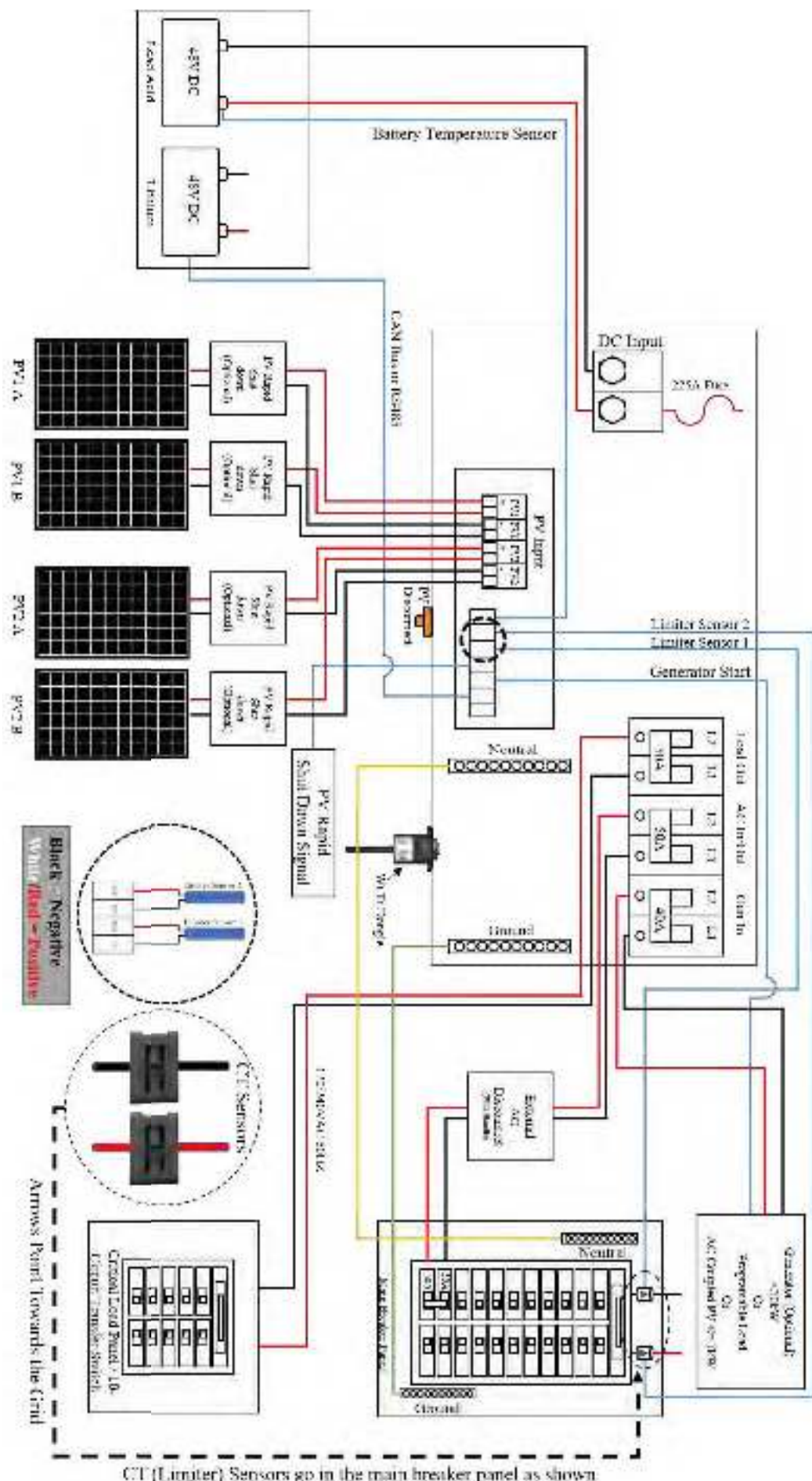

# >10KW Generator Diagram

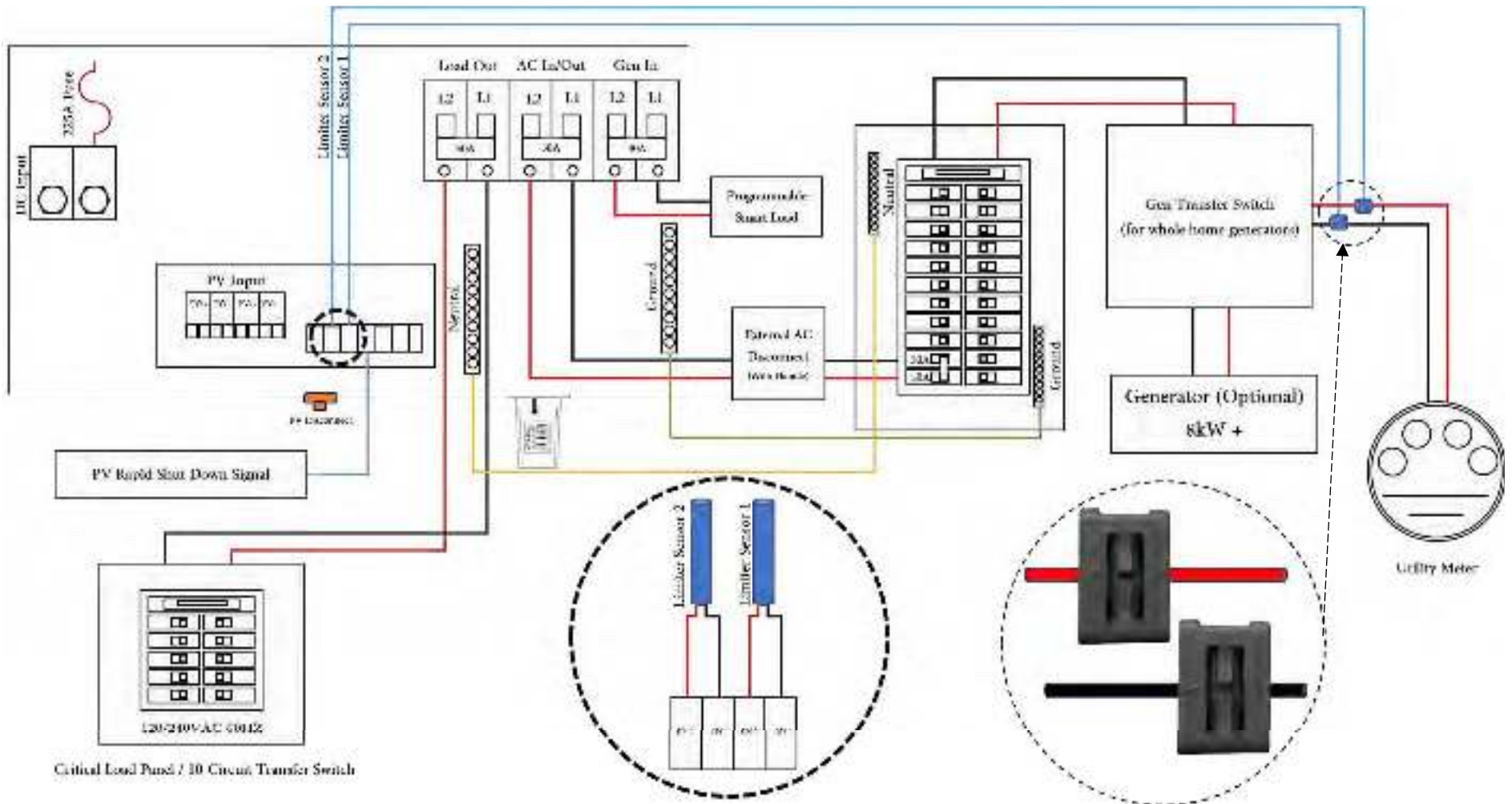

White = Positive Black = Negative

Arrows point toward Grid

## 10. Connecting a Back Up Generator (240V only)

- a. Generators Smaller than 10kW -see page 11
  - i. Connect the generator output to the Gen input breaker in the Sol-Ark 8K user panel.
  - ii. If your generator is small and only supports 120V, we suggest getting a 120V to 120/240V transformer. It will rarely be used.
  - iii. If **Off-Grid** connect the output of the generator to the grid input on the Sol-Ark
- b. Generators larger than 10kW -see page 12
  - i. If off grid, you may connect the output of the Generator directly to the Grid input on the Sol-Ark 8K. It can then treat the generator as if it were the grid. Since you are off Grid, you will have Grid Sell off and don't even need the current limiting sensors. Under Grid Setup, select "Limited to Load", disable UL1741 and increase Grid freq range: 53-65Hz.
  - ii. Limited Home mode works well with generators. If using a large generator with a whole home transfer switch, we suggest not using the Gen input breakers in the Sol-Ark, but your normal home wiring to distribute the Generator's power (through your existing Gen transfer switch).

## 11. Sensor and accessory Placement

- a. Limiter sensors
  - i. Install on incoming electrical service wires on L1 and L2 (see diagram pg. 11). Needed if selling power to whole home.
- b. Battery Temp Sensor
  - i. Place between batteries
- c. CanBus & RS485
  - i. Connect Batteries to Sol-Ark 8K via RJ45, you will need to splice the end that connects to the Sol-Ark 8K. Use the middle two conductors.
- d. Gen Start Signal
  - i. Normally open relay that closes when the Gen Start state is active
  - ii. If your generator only starts with the loss of 120/240V to the generator, we suggest using a DPST relay to the output of the inverter.
- e. PV Rapid Shutdown Signal
  - i. 12v signal/200mA power is present until the Sol-Ark is shut down with the front button
- f. WI-FI Antenna
  - i. Only needed for remote monitoring or software updates.

## 12. Testing and Powering up Sol-Ark 8K

- a. Check Voltage of each PV input circuit
  - i. Should be no higher than 500Vdc open circuit.
  - ii. DO NOT connect PV+ OR PV- to GND.
  - iii. Good to verify polarity.
- b. Check Grid Input Voltage (voltages shown are for North America)
  - i. Ensure 120Vac L1 to Neutral and L2 to Neutral
  - ii. Ensure 240Vac L1 and L2
  - iii. Check Neutral and Ground are ~0V AC
- c. Check Battery voltage
  - i. Turn on battery switch (if using a Lithium battery)
  - ii. Voltage should be 45Vdc-57Vdc

- d. If all checks out, Turn on Breakers for Grid and Load, Turn PV Disconnect knob to “On”
- e. System will boot up with power from PV, Grid, or ON/Off Batt.
- f. Press the ON/OFF Button on the front, light should come on.
- g. If you installed limit sensors for Limited Home selling mode, it is critical you verify the proper sensor and direction.
  - i. Using AC multi-meter, verify L1 voltage on AC in/out is 0Vac with main L1 connection in panel. Same for L2.
  - ii. To verify sensor connections to Sol-Ark, try removing one sensor from the main L1 connection. The power should drop to 0W.
  - iii. To verify proper sensor direction, with any loads in the home, the HM: +watts will be positive. If you turn on solar panels and turn enable Grid Sell, you should see HM: -watts if you are producing more power than the loads are consuming. And if you turn on limited power to Home mode, then HM: ~0 watts to zero the meter (system matches the loads to within 99%).

### 13. Basic Setup

- a. Display: Auto dim must be enabled for LCD screen to be covered by warranty. Color LCD screens dim if left on continuously for years.
- b. Time: Set date and time for the system

### 14. Programing Battery Settings

- a. Battery Size
  - i. This allows Sol-Ark to know the size of the battery bank. The system is also self-learning as batteries age.
  - ii. Main Menu → System Settings → Battery Setup → Batt → Batt Capacity
- b. Use Battery Voltage or % Charged
  - i. Use whatever you are comfortable with. Most installers prefer voltage, while most homeowners prefer % Charged.
- c. Battery Charge & Discharge Current
  - i. For AGM and Flooded, we recommend Ah battery size x 20% = Charge/Discharge amps
  - ii. For Lithium, we recommend Ah battery size x 50% = Charge/Discharge amps
  - iii. For Gel, follow manufacturer’s instructions.
  - iv. When Off Grid, discharge current is not limited, so the inverter will always stay on.
- d. Battery Type
  - i. Navigate to the charge menu and set the values appropriate to your battery chemistry. The owner’s manual is good reference for lead acid batteries.
  - ii. Main Menu → System Settings → Battery Setup → Charge

Battery Type	Absorption Stage	Float Stage	Equalize Stage (every 20 days 2.0hr)
AGM (or PCC)	14.4v ( <b>57.6v</b> )	13.8v ( <b>55.2v</b> )	
Gel	14.1v ( <b>56.4v</b> )	13.5v ( <b>54.0v</b> )	
Lithium	14.1v ( <b>58.0v</b> )	13.2v ( <b>56.0v</b> )	
Flooded	14.6v ( <b>58.4v</b> )	13.8v ( <b>55.2v</b> )	15.1v ( <b>59.0v</b> )

Default

e. Battery Discharge

- i. Allows the user to define the depth of discharge the system will allow before using the grid/generator to charge the battery bank. Solar is always the first priority in charging the battery bank.
- ii. Main Menu → System Settings → Battery Setup → Discharge

**15. Grid Setup**

- a. Grid Sell: maximum watts sold to grid
- b. Limited to Home: Limits power produced by the system to match the demand of the home
- c. Limited to Load: Limits power produced by the system to match the demand of connected loads

**16. Remote Monitoring Setup**

- a. WIFI (Via Cell Phone or computer)
  - i. Plug WIFI dongle into sol-ark
  - ii. If using a cell phone, turn off cellular
  - iii. Using your device look for WIFI networks and select the one that matches the PN number on your dongle
    - Password: 12345678 (Once Dongle is set up in this can be changed)
  - iv. Once connected, use a web browser to navigate to 192.168.8.66 (type it into the address bar) and log in
    - Username: admin (Once Dongle is set up in this can be changed)
    - Password: admin (Once Dongle is set up in this can be changed)
  - v. Once Connected to the Dongle
    - Follow the guide below

Once Connected, Dongle will have a solid green LED (Right) or all green LEDs (Left)

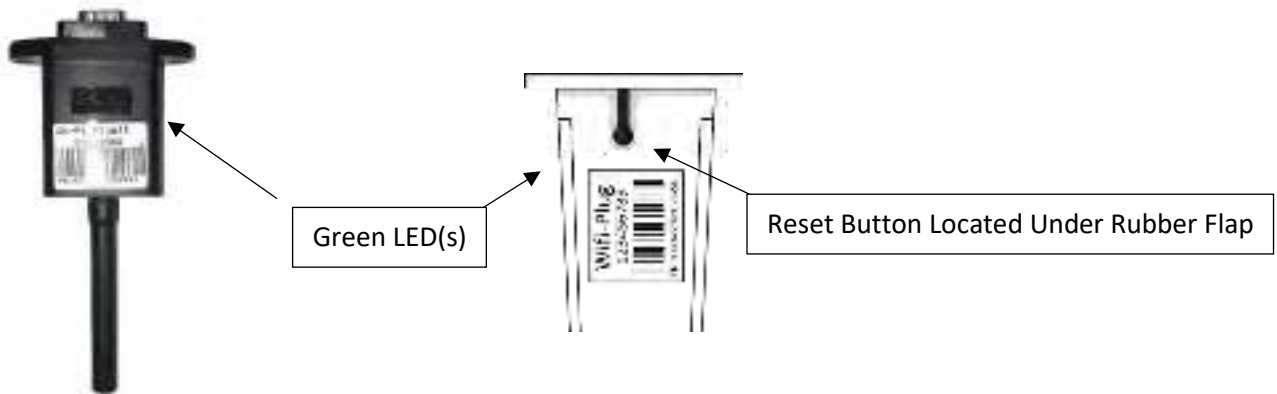

# Phone App Setup Instructions

**1**  
Download the App



SmartESS



iOS Download Link



Android Download Link

Use a QR code reader app to scan the link for your OS

**2**  
Connect to dongle

Go to your phone settings



Select Wi-Fi settings



Select the network that matches the #N# on the dongle



Default Password: 12345678



Once connected Open the SmartESS App





### Wi-Fi Setup

3

Select Wi-Fi Configuration

If you see this error refer to step 2

Once connected return to the app

Select Connect Wi-Fi

Select the Wi-Fi can

Select confirm

Select your Wi-Fi network

Enter password and select "Settings"

### Registration

4

Select Register

Select the "I\*" icon

Point your phone's camera at the dongle barcode then select Register

When step 3 is complete all 4 of the lights on the dongle should be green (as seen here)



### Log In & Basic Setup

5

Enter the credentials you registered with

Select your device

Select your PIN #

Select Design power

Enter the WZ capacity of your install

Select time zone

Select your time zone

**Manual Wi-Fi Setup without Phone App (Skip if you used the phone app setup)**



Username: admin Password: admin



Select "English"



Select: "STA Interface Setting"



Select: "Search"  
If Network Password: Enter it here and Apply

Model	SSID	Address	Bandwidth	Channel	Mode	WiFi Type	Manufacturer
MaxLinear	7032ae7116be	0%	1	ADD	WiFi2700	Manufacturer	
Qual	0008e081e886	0%	9	ADD	WiFi2700	Manufacturer	
TP-LINK	af004447113a	0%	10	ADD	WiFi2700	Manufacturer	
TP-LINK	02004b19011a	0%	10	ADD	WiFi2700	Manufacturer	
AS Serials	00100ad07a24e	0%	1	ADD	WiFi2700	Manufacturer	
TP-LINK	0008e081e886	0%	9	ADD	WiFi2700	Manufacturer	
TP-LINK	00100ad07a24e	0%	10	ADD	WiFi2700	Manufacturer	

Select Your Network Then Apply

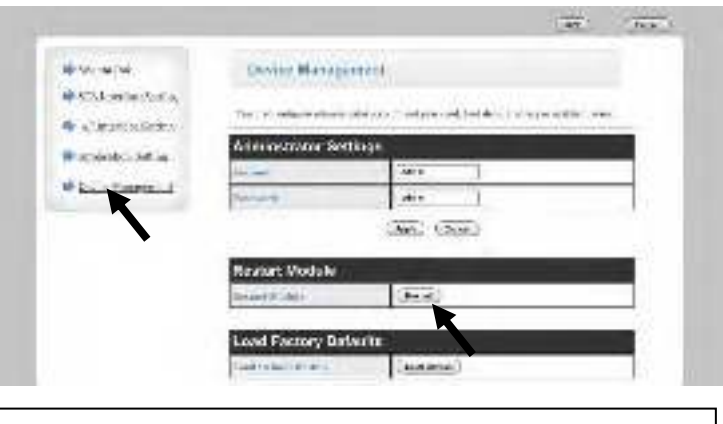

Select: "Device Management"  
Then Restart Dongle

Note: If you setup a new password for your WIFI, the first character of the password must be either 0-9 or A-Z and "=" is not supported.

## Manual Wi-Fi Setup without Phone App (Skip if you used the phone app setup)

### b. Phone App

- i. IOS Download Link: <https://itunes.apple.com/US/app/id1334656760?mt=8>
- ii. Android Download Link:  
[https://play.google.com/store/apps/details?id=com.eybond.smartclient&hl=en\\_US](https://play.google.com/store/apps/details?id=com.eybond.smartclient&hl=en_US)



IOS Download Link



Android Download Link

### a. Registering WIFI (Via Cell Phone or computer)

- i. Using the browser on your device that is connected to the internet, navigate to:
  - <http://www.dessmonitor.com/>
- ii. In the upper right-hand corner use the dropdown menu to select English
- iii. Then select “Register immediately”
  - Fill in the credentials and make sure to remember or write down your login credentials



Note 1: The PN number is the number on the WIFI dongle that is connected to the Sol-Ark

Note 2: Registration of your system can also be done via the Smart ESS App

## WIFI Troubleshooting:

- Light on the dongle won't turn green when connecting to WIFI:
  - If using a cell phone, make sure the cellular function is turned off
  - Try turning off your local wireless router until you finish setup above
  - You may need to reset your dongle (see below)
- Light on dongle is green but system cannot be seen by the application on PC or App.
  - Make sure your local wireless router that the Sol-Ark is connected to is connected to the internet
- General troubleshooting techniques:
  - Make sure that the dongle is plugged in all the way
  - Unplug the dongle and plug it back in
  - Reset the dongle
  - Uninstall phone app and reinstall
- How to Reset the WIFI Dongle
  - While the dongle is plugged into the Sol-Ark and has power, press and hold the reset button for 10 seconds. The LED should turn red.
  - If Your dongle does not have a reset button, log into it and click "reset" under the device management tab.
- Which barcode should I scan when setting up the phone app?
  - The barcode on the WIFI dongle, not the QR code above

## E.M.P Systems only:

- **Suppressor installation**
- If your system was purchased with Lightning / EMP Hardening, the vast majority of protection is in the Sol-Ark. But you also have EMP suppressors that get installed on the power cords of appliances that are connected on the transfer switch. It's not critical, but best installed as close as possible to the appliance.
- You also have EMP suppressors that get installed on both solar panel wires with a zip tie. Closer to the panel is better. If you purchased the panels from us, we installed >150kV/m protection inside the solar panels.



April 15, 2019

If using panels not  
from Sol-Ark<sup>20</sup>

## Rapid Shutdown Hardware Diagram (Midnight RSD per PV string)

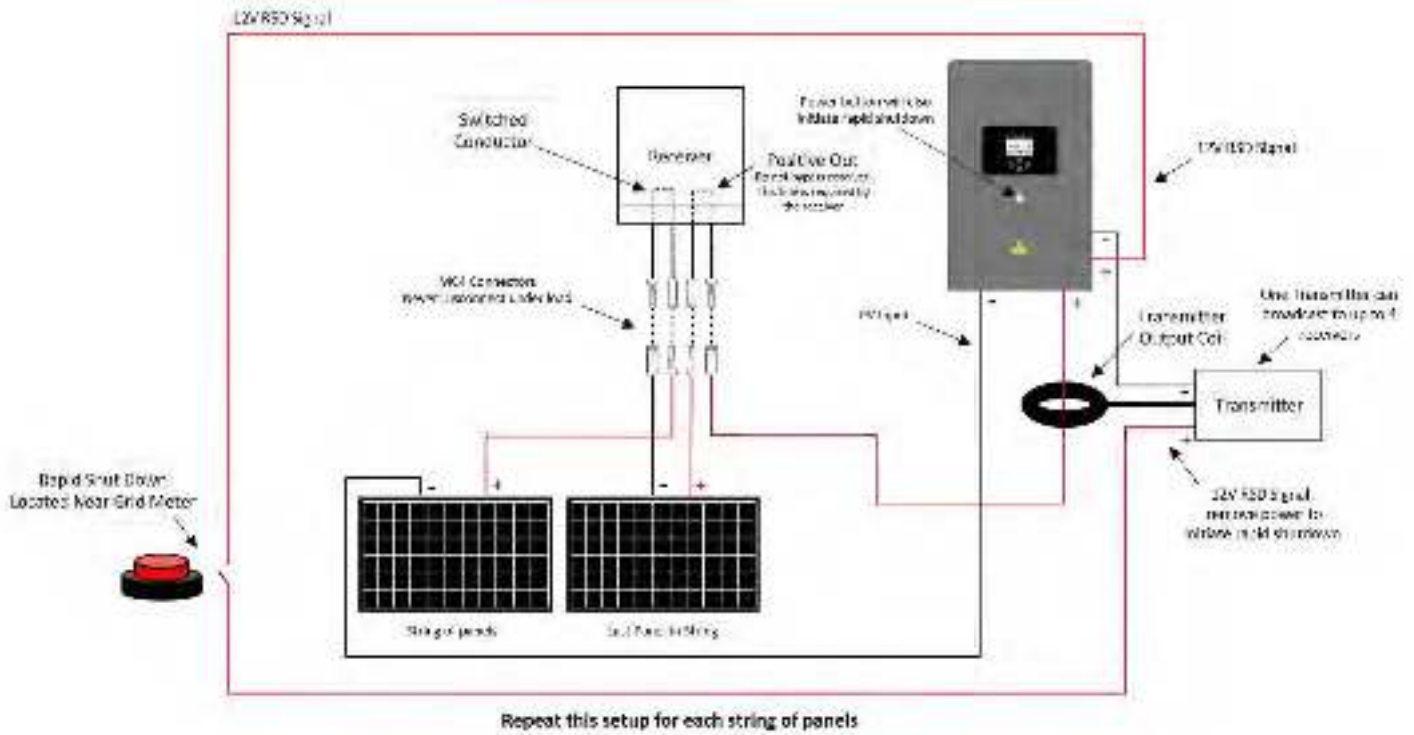

Note: Transmitter fits inside the user area of the Sol-Ark 8K

If String Level rapid shutdown is required for your install, each string of panels must have its own receiver module.

For NEC2017 module level shutdown, please refer to supplemental note.

## Sol-Ark-8K-48-ST Specifications

### Solar

Max allowed PV Power	11000W
Max allowed PV Power per MPPT	6000W
Max DC voltage	500V
MPPT voltage range	150-425V
Starting voltage	175V
Number of MPPT	2
Solar Strings per MPPT	2
Max DC current per MPPT	18A (self limiting)
Max AC Coupled Input (Micro/String Inverters)	7,000W
Max Combined Solar Input (DC+AC)	13,000W

### AC Output

Connections	120/240V split phase
Continuous AC power on Solar or Battery	9000W 37.5A L-L (240V) 4800W 40A L-N (120V)
Surge AC power 5sec	20,000VA L-L (240V) 10,000VA L-N (120V)
Frequency	60/50Hz
Continuous AC power with Grid or Generator	12000W 50A L-L (240V) 6000W 30A L-N (120V)
CEC Efficiency	96.5% (Peak 97.5%)
Idle Consumption typical – no load	60W
Sell back power modes	Limited to Household or Full Grid-Tied
Design (DC to AC)	Transformerless DC
Response Time (Grid-Tied to Off-Grid)	4ms
Power Factor	±0.9 - 1.0

### Battery (optional)

Type	Lead-Acid or Li-Ion
Nominal DC Input	48V
Capacity	90 – 2000Ah
Voltage Range	41.0 – 59.0V
Continuous Battery charging output	190A
Charging curve	3-stage w/ equalization
Grid to Battery Charging Efficiency	96.0%
External temperature sensor	included
Current shunt for accurate % SOC	integrated
External Generator Start based on voltage or % SOC	integrated
Communication to Lithium battery	CanBus & RS485

### General

Dimensions (H x W x D)	28.0" x 17.375" x 9.37"
Weight	75 lbs
Enclosure	NEMA type 1 (Indoor Use)
Ambient Temperature (4 variable speed fans)	-25 to 55C, >45C derating
Display	Color touch screen
Wi-Fi Communication (monitoring or SW updates)	integrated
Snap on sensors for limited selling to Household	included
Standard Warranty	5 years
Optional Extended Warranty	10 years

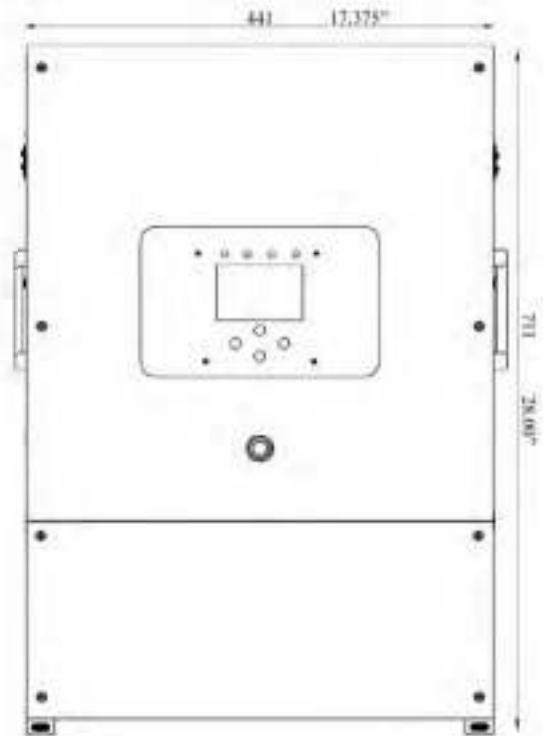
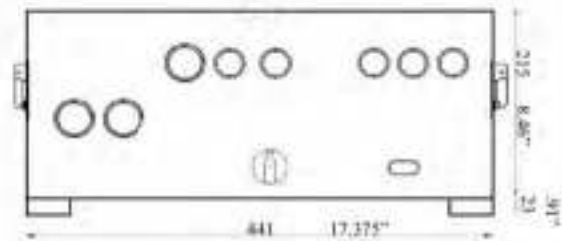

### Protection & Certifications

Electronics certified safety by SGS labs to NEC & UL specs – NEC 690.4B & NEC 705.4/6	Yes
Grid Sell Back – UL1741-2010/2018, IEEE1547a-2003/2014, FCC 15 class B, (April 2019: ULL1741SA, CA Rule 21, HECO Rule 14H)	Yes
PV DC disconnect switch – NEC 240.15	integrated
Ground Fault Detection – NEC 690.5	integrated
PV rapid shutdown control – NEC 690.12	integrated
PV Arc Fault detection – NEC 690.11/ UL1699B	integrated
PV input lightning protection	integrated
AC input/output 50A breakers	integrated
Battery overcurrent fuse	integrated
User wiring enclosure w/ ¼" & 1" knock-outs	integrated
Solar Flare/EMP Hardened to 2015 MIL-STD-461G (Independently tested June 2018)	optional

## How to upgrade to Sol-Ark 8K from Sol-Ark 3K

1. Power down Sol-Ark 3K
2. Unplug Sol-Ark from grid and transfer switch and rewire transfer switch (see below)
3. Disconnect the batteries from Sol-Ark 3K but leave them wired to 48V (unless you are upgrading to more than 16 batteries)
4. If you are upgrading to more than 16 batteries you will need to change some of your battery cables (let us know when you order)
5. Remove Sol-Ark 3K
6. Rewire your solar panels in accordance with pages 9/10.
7. Install 2-pole 50A breaker in your breaker box using 6AWG wire (these replace the 30A outlet as the grid input)
  - a. Also connect Neutral and Ground from breaker box to the Sol-Ark 8K
8. Install Sol-Ark 8K (refer to diagram on pages 11/12)

### 6-Circuit Transfer Switch (if 1 switch): converting it from 120V 1phase to 120/240V 2 phase

If you are using the 6-circuit switch that came with Sol-Ark 3K with your new Sol-Ark 8K, you will need to rewire it so that it supports split phase.

1. Disconnect power to the switch
2. Remove the front plate
3. Remove wire nuts from the white (neutral) wires and the black and red wires
  - o Leave the green (ground) wires connected
4. Cap the White wire that connects to the neutral buss in the breaker panel (it will not be used)
5. Relabel the white wire from the cable that connected the switch to the Sol-Ark 3K as Red
  - o Use electrical tape or any other permanent labeling technique
6. Wire nut the red wires together
  - o The newly labeled red wire and the one previously connected to black
7. Wire nut the black wires together
8. Remove the plug from the cord attached to the switch and strip the outer insulator about 6"
9. Relabel the white wire as red
10. Connect the black wire from the newly striped end of the wire (where the plug used to be) to L1 on the Sol-Ark 8K output.
11. Connect the red wire (the one that used to be white) from the newly striped end of the wire (where the plug used to be) to L2 on the Sol-Ark 8K Load output.
12. Connect the green wire (ground) from the newly striped end of the wire (where the plug used to be) to the ground bus in the Sol-Ark 8K

### 6-Circuit Transfer Switch (if 2 switches): connect SW1 to L1 & SW2 to L2 to balance loads

1. Disconnect power to switch 1
2. Remove the plug from the cord attached to the switch and strip the outer insulator about 6"
3. Cap the white wire and the green wire
4. Connect black wire to L1 of the Sol-Ark 8K output
5. Repeat steps 1-3 for switch 2
6. Connect the black wire from switch 2 to L2 of the Sol-Ark 8K output

# Off-Grid Install Tips

- Limiter Sensors are not required for completely Off-Grid installs.
- The Grid input breaker on the Sol-Ark should be used as the Generator input (4-30kW generators) so that you maintain Smart Load output capability when off-grid. Smart Load will allow you to run high power non-essential appliances (hot water, dehumidifier, heat pump, irrigation pump) on solar power instead of batteries. Therefore, you will use Grid Charge (default) in the Battery Setup/Charge menu.
- When off grid there is no need for a transfer switch, simply connect the load output of the Sol-Ark to the whole home.
- Do not use Grid Sell or Limited to Home Modes. Only Limited power to load (default).
- The Auto Generator start functions as a 2-wire switch (closes the circuit when needing charging)
  - Auto Genstart will be triggered when the battery voltage or percent reaches the level programed in the battery setup menu. Then once triggered the generator will continue to charge the batteries until they are about 95% full (this percentage is not programmable) before turning the generator off.



- Under setup for Grid/Sell Control, turn off UL 1741. Then go to Grid/Grid input to widen the input frequency range to 53-65Hz to work with any frequency generator.
- If you are using a small portable generator, you may need to purchase an electrical filter from us to clean up the noisy power from the generator enough for the Sol-Ark to use it.
- If you would like to use a wind turbine in conjunction with Sol-Ark 8K, the turbine must have a 48V charge controller with a dump load as to prevent overcharging of the batteries. Simply connect the charge controller on the turbine to the battery bank the Sol-Ark is using and the turbine will help charge your batteries.
- Don't forget to set the Battery capacity and proper charge rates.

# Grid-Tie / No Battery Install Tips

- Under Battery setup, select no Battery (or system will beep).
- Under Grid setup, select Grid Sell.
- Touch Battery Icon to see the Detailed Volts View to verify your inputs & outputs.

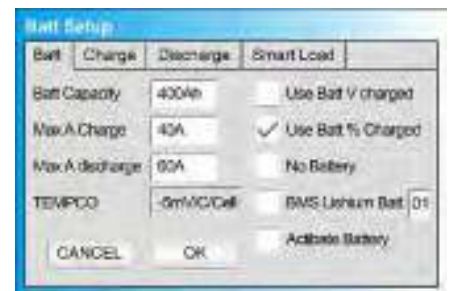

Solar	Grid	IN	Load	Bat
00V	00V	00%	0%	75%
	50.0Hz	50.0Hz		77%
11.0V	117V	10%	10%	11.10V
11.4	116.14V	11.4		11.86A
10V	113.10V	10%	0%	0.1K
11.0V	117V	10%	10%	
0.75	116.74V	0.75		07.50 10
0V	113.07V	0%	0%	40.40.30



# Sol-Ark 8K Owner's Manual

## Powering on the system:

1. Make sure that Sol-Ark 8K is properly connected to the batteries, panels, grid, etc. (see system wiring diagram)
2. Turn on grid power breakers
3. Press the power button on the front of the unit
4. Make sure Solar panel inputs are not connected to Ground, then Turn on DC disconnect switch
5. Turn on load breakers

## Indicator LEDs

- **DC**
  - Green = Solar Panels are producing
  - Off = Solar Panels are not producing
- **AC**
  - Green = Grid is Connected
  - Off = Grid is not Connected
- **Normal**
  - Green = Sol-Ark 8K is working properly
  - Off = Sol-Ark 8K is not working properly (call us)
- **Alarm**
  - Red = Alarm, check the alarms menu
  - Off = No alarms

## Selecting your Power Mode:

Sol-Ark 8K will simultaneously use the different power sources available to it in order to meet the demand of loads. The following power modes allow the user to determine the power sources available to Sol-Ark 8K.

- Limited Load / Self Consumption
  - Sol-Ark will only power the loads connected to it and will not produce more power than the connected loads require. This mode will not sell back to the home or grid.
- Limited Home (zeroing home meter)
  - Pushes power to your whole home, without selling back any excess to the grid (no net metering agreement required)
  - This mode requires the use of the limiter sensors
    1. Main Menu → System Settings → Grid Setup → Limiter → Limited to Home
  - Power source priority is same as Grid Sell Back
- Grid Sell Back
  - This Mode allows Sol-Ark 8K to sell back any excess power produced by the solar panels to the grid.
  - If home has a backup generator, this mode requires Limiter Sensors. See “Backup Generator set-up”
    1. Main Menu → System Settings → Grid Setup → Limiter → Grid Sell
  - Power source priority is as follows:
    1. Solar Panels
    2. Grid
    3. Generator
    4. Batteries (until programable % discharge is reached)
- Time of Use (using batteries during peak power times)
  - Only available when using Limited Home mode or grid sell back modes

- Use your batteries to reduce power consumption from the grid during a user programable peak pricing window of time.
  1. Main Menu → System Settings → Grid Setup → Limiter → Time of Use
- Power source priority is as follows:
  1. Solar Panels
  2. Batteries (until programable % discharge is reached)
  3. Grid (can control when Grid charges)
- Off-Grid (powering loads)
  - This mode does not need to be programmed, Sol-Ark 8K will automatically operate in Off-Grid Mode in the absence of the grid.
  - Power source priority is as follows:
    1. Solar Panels
    2. Batteries
    3. Generator

### **Backup Generator set-up:**

- Generators Smaller than 10kW
  - Connect to the generator output to the generator input breakers in the Sol-Ark 8K user panel.
- Generators larger than 10kW In Full Grid Sell Mode
  - Usually large generators have a whole home transfer switch that feeds the home. We suggest not using the Generator input breakers in the Sol-Ark but your normal home wiring to distribute the Generator's power (through your existing Gen transfer switch).
  - If off grid, connect the output of the Generator directly to the Grid input on the Sol-Ark 8K. It can then treat the generator as if it were the grid. This is to say that the sensors are placed before the generator output in the circuit with respect to the grid connection to your home. Failure to properly place the current sensors can result in permanent damage to Sol-Ark 8K and/or your home generator. Grid sell + Gen on grid input can damage system.
- Auto Gen Start Signal
  - Automatically start compatible backup generators
  - The threshold at which gen charging is triggered can be set using the input boxes above the checkbox.
  - Main Menu → System Settings → Battery Setup → Charge → Gen charge

### **Sensors:**

- Limiter Sensors (Current Sensors)
  - Placed on the grid side of your home breaker panel and are required to enable limited mode (see diagrams).
- Battery Temperature Sensor
  - Placed on the battery bank and used to adjust charging voltage and capacity calculations
- PV Shutdown signal
  - Used to accommodate Rapid Shutdown of PV components and discharge onboard capacitors
- CanBus / RS485
  - Used to communicate with Lithium batteries

## Batteries:

Supported Battery Chemistries (48V configuration required for all chemistries)

- Lead Acid
  - AGM
  - Gel
- Lithium
  - NMC
  - LiPo4
- NiFe

## Programming Battery Settings

- f. Battery Size
  - i. This allows Sol-Ark to know the size of the battery bank
  - ii. Main Menu → System Settings → Battery Setup → Batt → Batt Capacity
- g. Battery Type
  - i. Navigate to the charge menu and set the values appropriate to your battery chemistry. The chart on page (14) is good reference for lead acid batteries.
  - ii. Main Menu → System Settings → Battery Setup → Charge
- h. Battery Discharge percentage
  - i. Allows the user to define the depth of discharge the system will allow before using the grid/generator to charge the battery bank. Solar is always the first priority in charging the battery bank.
  - ii. Main Menu → System Settings → Battery Setup → Discharge

## Remote Monitoring Setup

- c. **WIFI (Via Cell Phone or computer) See pages 14-19 for more**
  - i. Plug WIFI dongle into sol-ark
  - ii. If using a cell phone, turn off cellular
  - iii. Using your device look for WIFI networks and select the one that matches the PN number on your dongle
    - Password: 12345678
  - iv. Once connected, use a web browser to navigate to 192.168.8.66 (type it into the address bar) and log in
    - Username: admin
    - Password: admin
  - v. Navigate to the wizard tab
    - Enter your local network credentials
    - Select English option
    - Follow the menu option to edit the systems WIFI AP and log in credentials

## Screens

- **Home Screen (Touchscreen)**

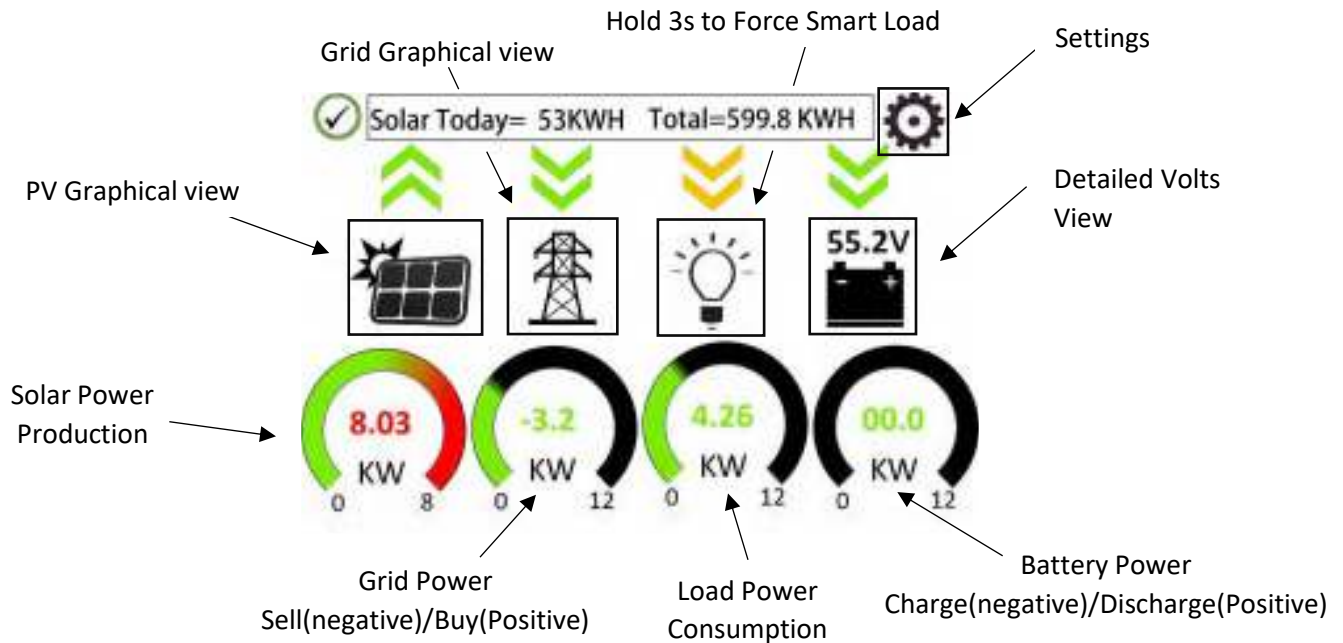

- **Detailed Volts View**

- Top row = Total power for column
- Middle Row = Line 1/PV1 voltage, Amps, and Watts (note: PV Voltage not to exceed 500)
- Bottom Row = Line 2/PV2 voltage, Amps, and Watts (note: PV Voltage not to exceed 500)
- Batt Temperature will show -20°C if temperature sensor is not connected
- Batt SOC % = % batteries are charged
- DC Temp = Temperature of DC conversion electronics
  - Batt → AC
  - PV → Batt
  - AC → Batt
- AC Temp = Temperature of AC conversion electronics
  - Batt → AC
  - PV → AC
- Grid Column
  - If selling to grid, Grid Watts = negative
  - If buying from grid, Grid Watts = positive
  - Note: if these values are reversed, current sensors may be installed incorrectly (reverse polarity)
  - HM = Power detected by the external current sensors on entire home L1 & L2
  - LD = Power detected using internal sensors on AC grid in/out breaker

In Limited to home Mode HM values will be close to zero. HM values should never be negative. If negative, the Limiter Sensors are not installed properly.

Solar	Grid	HV	Load	Batt
00%	00%	00%	00%	75%
	50.012	-50.012		37%
L1-02	117V	10V	10V	21.13V
H1-4	18.14V	11.24		1.96A
H2	10.05V	10%	0%	0.1K
L2-02	112V	10V	10V	
H1-3	18.14V	0.24		07.50.10
00%	LD-02	0%	0%	40.40.00

**Possible Limiter Sensor issues:**

- Sensors are facing wrong direction
- Sensors are on the wrong wire(s)
- Sensors are not fully closed on wire(s)
- Sensor Polarity is wrong (White = + BLK = -)

- **PV Graphical View**
  - Displays power production over time for the PV array
  - Use up/down buttons to navigate between days
  - Month view, Year view, and Total view
- **Grid Graphical View**
  - Displays power drawn from and sold to the grid over time
  - Bars above the line indicate power bought from the grid
  - Bars below the line indicate power sold back to the grid
  - This view can be helpful in determining when the most power is used in the home and for time of use programming
- **System Setup Menu**
  - ID = LCD serial #. But we use the WIFI serial #.
  - COMM = LCD software version
  - MCU = Inverter software version
- **System Alarms**
  - Lists all system alarms
- **Basic Setup**
  - Display
    - Brightness adjustment
    - Auto dim (must be enabled for LCD screen to be covered by warranty)
  - Time
    - Set date and time for the system
  - Alarms & Safety
    - Arc fault detects if a poor connection in the PV wires
- **Batt Setup**
  - Batt
    - Batt Capacity: enter the size of the battery bank connected to the system
    - Max A charge: set the max charge rate for the batteries
    - Suggest 20%-30% of battery capacity for lead acid
    - Max A discharge: set max discharge for battery bank (this value will be ignored in off-grid mode to allow for constant power to loads)
    - TEMPCO: Temperature coefficient used in conjunction with the batt temp sensor to adjust optimal voltages for lead acid batteries
    - Use Batt V charged: displays battery charge in terms of voltage
    - Use Batt % charged: Battery voltage can be misleading for determining the % Charged. So, we use algorithms measuring power in and out to measure a true value for % Charged. It compensates for aging batteries also.
  - Charge
    - Float V: Set value appropriate for the batteries connected to the system using chart (Page 14/34)



Alarm Code	Occurred
F96 DC_VoltLow_Fault	2018-10-24 01:07
F96 DC_VoltLow_Fault	2018-10-24 01:07
F96 DC_VoltLow_Fault	2018-10-24 01:00
F96 DC_VoltLow_Fault	2018-10-24 00:55
F96 DC_VoltLow_Fault	2018-10-24 00:43
F96 DC_VoltLow_Fault	2018-10-24 00:10
F96 DC_VoltLow_Fault	2018-10-24 00:08
F96 DC_VoltLow_Fault	2018-10-24 00:07

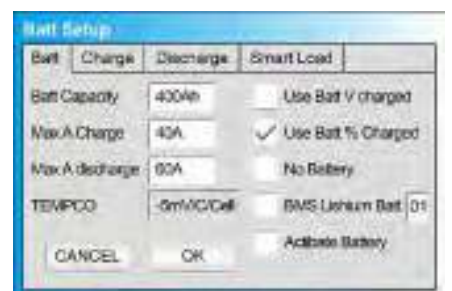

- Absorption: Set value appropriate for the batteries connected to the system using chart (Page 14)
  - Absorption will stop at 1% of the capacity of the battery bank and drop to float
  - Ex: 400Ah battery would be 4A
- Equalization: Set value appropriate for the batteries connected to the system using chart (Page 14)
- Days: period of time between equalization cycles
- Hours: period of time taken to equalize batteries
  - Note if Hours = 0 system will not equalize the batteries
- Gen Charge: uses the gen input of the system to charge battery bank from an attached generator.
  - Start V: voltage at which system will AutoStart a connected generator to charge the battery bank
  - Start percentage: Percent S.O.C at which system will AutoStart a connected generator to charge the battery bank
  - A: charge rate from the attached generator in Amps
    - Note: size this value appropriately for your given generator size
- Grid Charge
  - Start V: voltage at which system will charge the battery bank from the grid. If grid is on, batteries will stay at float voltage.
  - Start percentage: Percent S.O.C at which system will AutoStart a connected generator to charge the battery bank
  - A: charge rate from the grid in Amps



○ **Discharge**

- Shutdown V: battery voltage at which the inverter will shut down (batt symbol on home screen will turn red)
- Low Batt: Low battery voltage (batt symbol on home screen will turn yellow)
- Restart: battery voltage at which AC output will resume
- Batt Resistance: used in % SOC batt calculations
- Batt Charge Efficiency: used in % SOC batt calculations



○ **Smart Load (Gen Load)**

- This mode utilizes the Gen input connection as an output which only receives power when the battery is above a user programmable threshold.
- The Gen input breaker in the user area of the system becomes an output to high power loads such as a water heater, irrigation pump, ac unit, pool pump.
- Smart Load OFF Batt
  - Battery voltage at which the Gen load will stop being powered
- Smart Load ON Batt
  - Battery voltage at which the gen load will start being powered
- Note: if using Gen load for a water heater, it is recommended that only one leg (120V) is connected to the bottom element. This significantly reduces the power consumption of the water heater while retaining core functionality (it will heat water, only slower)
- Note: Gen Load is limited to 40A at 240V (Do not exceed!)



- Solar Watts is for on grid.
  - System waits to turn on smart load until sufficient PV power is produced (when on grid).
- **AC Coupling Settings (For Micro Inverter Input)**
  - To use the Grid input breaker as a micro inverter AC coupled input, check the “For Micro inverter Input” box (this feature will also work with “Grid-Tied” Inverters)

- 13kW = Maximum combined input to Sol-Ark (AC+DC)
  - Best: 3kWAC + 10kWDC
  - Good: 4kWAC + 9kWDC
  - OK: 2kWAC + 11kWDC
  - OK: 5kWAC + 8kWDC
  - OK: 6kWAC + 7kWDC
  - OK: 7kWAC + 6kWDC



- **Grid Setup**
  - Limiter

- Grid Sell: maximum watts sold to grid
- Limited to Home: Limits power produced by the system to match the demand of the home
- Limited to Load: Limits power produced by the system to match the demand of connected loads
- Time of Use:
  - Time: When the system will sell batt/PV power to the grid or home
  - Power(W): Max watts to be sold from the battery at each time
  - Batt: The battery voltage or % at which the system will limit selling to the grid or home from the battery. The system will drain the battery until that percent/voltage is reached.
  - Charge: Enables grid charging during a selected period. PV will always charge to 100%.
  - Example:
    - The setting below will use up to 40% of the battery bank to sell back power between the hours of 5:00AM and 4:59PM and charge them back up using available solar power from 5:00PM to 8:59PM. Then between the hours of 9:00PM and 4:59AM the batteries will be charged off the grid and not discharged.
      - 1:00AM 8000 100% (✓)
      - 5:00AM 8000 60% ( )
      - 9:00AM 8000 60% ( )
      - 1:00PM 8000 60% ( )
      - 5:00PM 8000 100% ( )
      - 9:00PM 8000 100% (✓)
- Note: This mode requires Grid sell / limited to home be enabled
- Note: If you need the batteries to never charge from the grid, uncheck the “Grid Charge” box under the charge tab of the battery menu (see page 30)



- **Sell Control**

- UL 1741 & IEEE1547: Enables compliant functionality
- All other functions on this screen may be enabled in the future

- **Grid Input**

- Grid Frequency: Select the frequency of the grid connected to the system
- Grid Type:
  - 220V Single Phase (Call us before using)
  - 120/240 Split Phase (North America)
  - 120/208V 3 Phase (enabled in a future update)
- Protect Parameters
  - Settings when the system will connect/disconnect from grid
  - This is not used when UL 1741 & IEEE1547 is enabled
  - You may need to widen the frequency range when using a generator (53-65 Hz)



- **FreqVolt**

- **Puerto Rico Grid Compliance Settings (UL 1741SA must be enabled in “Sell Control” tab):**



- **Kauai Grid Compliance Settings (UL 1741SA must be enabled in “Sell Control” tab):**



- **PowFac**

- Power Factor is programmable from 0.9 – 1.0.

# Battery Charging Information

## 4-Stage Charging

The MPPT has a 4-stage battery charging algorithm for rapid, efficient, and safe battery charging. Figure below shows the sequence of the stages.

MPPT Charging Algorithm

### Bulk Charge Stage

In Bulk charging stage, the battery is not at 100% state of charge and battery voltage has not yet charged to the Absorption voltage setpoint. The controller will deliver 100% of available solar power to recharge the battery.

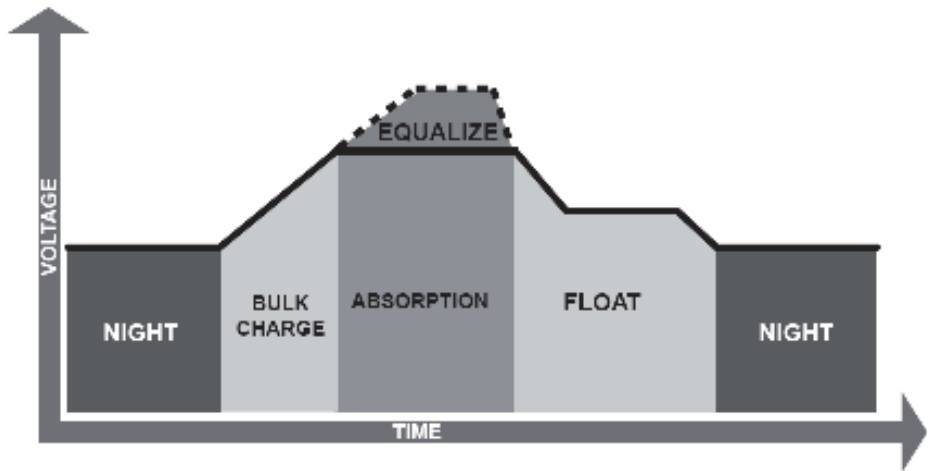

### Absorption Stage

When the battery has recharged the Absorption voltage setpoint, constant-voltage regulation is used to maintain battery voltage at the Absorption setpoint. This prevents heating and excessive battery gassing. The battery is allowed to come to full state of charge at the Absorption voltage setpoint. Absorption lasts until batteries charge at 1% of programmed Ah size.

### Float Stage

After the battery is fully charged in the Absorption stage, the MPPT reduces the battery voltage to the Float voltage setpoint. When the battery is fully recharged, there can be no more chemical reactions and all the charging current is turned into heat and gassing. The float stage provides a very low rate of maintenance charging while reducing the heating and gassing of a fully charged battery. The purpose of float is to protect the battery from long-term overcharge.

### Battery Charging Setpoint (48V)

Battery Type	Absorption Stage	Float Stage	Equalize Stage (every 90 days 0.0hr)
AGM (or PCC)	14.4v (57.6v)	13.8v (55.2v)	
Gel	14.1v (56.4v)	13.5v (54.0v)	
Lithium	14.1v (58.0v)	13.2v (56.0v)	

Default

**Note:**

When batteries are in series, the voltages add to each other.

When batteries are in parallel the Amp hours add to each other.

How to calculate Amp Hours for your battery bank (PCC 200):

Battery Count	Voltage per Battery	Amp Hours per Battery	Total Amp Hours @48V	Max Charge/ Discharge Amp
4	12V	180Ah	180Ah	36A
8	12V	180Ah	360Ah	72A
12	12V	180Ah	540Ah	108A
16	12V	180Ah	720Ah	144A

# Warranty

5-Year Limited Warranty for SOL-ARK (Portable Solar LLC) Products. Sol-Ark provides a Five-year (5) limited warranty (“Warranty”) against defects in materials and workmanship for its Sol-Ark products (“Product”). The term of this Warranty begins on the Product(s) initial purchase date, or the date of receipt of the Product(s) by the end user, whichever is later. This must be indicated on the invoice, bill of sale from your installer. This Warranty applies to the original Sol-Ark Product purchaser and is transferable only if the Product remains installed in the original use location. Please call Sol-Ark to let us know if you are selling your home and give us name and contact of the new owner.

The warranty does not apply to any Product or Product part that has been modified or damaged by the following:

- ❖ Installation or Removal (examples: wrong voltage batteries, connecting batteries backwards, damage due to water/rain to electronics, preventable damage to solar wires.)
- ❖ Alteration or Disassembly
- ❖ Normal Wear and Tear
- ❖ Accident or Abuse
- ❖ Unauthorized Firmware updates/software updates or alterations to the software code
- ❖ Corrosion
- ❖ Lightning; unless using EMP hardened system, then Portable Solar will repair product
- ❖ Repair or service provided by an unauthorized repair facility
- ❖ Operation or installation contrary to manufacturer product instructions
- ❖ Fire, Floods or Acts of Nature
- ❖ Shipping or Transportation
- ❖ Incidental or consequential damage caused by other components of the power system
- ❖ Any product whose serial number has been altered, defaced or removed
- ❖ Any other event not foreseeable by Portable Solar, LLC

Sol-Ark (Portable Solar LLC) liability for any defective Product, or any Product part, shall be limited to the repair or replacement of the Product, at Portable Solar LLC discretion. Sol-Ark does not warrant or guarantee workmanship performed by any person or firm installing its Products. This Warranty does not cover the costs of installation, removal, shipping (except as described below), or reinstallation of Products or parts of Products.

THIS LIMITED WARRANTY IS THE EXCLUSIVE WARRANTY APPLICABLE TO SOL-ARK (PORTABLE SOLAR LLC) PRODUCTS. SOL-ARK EXPRESSLY DISCLAIMS ANY OTHER EXPRESS OR IMPLIED WARRANTIES OF ITS PRODUCTS. SOL-ARK ALSO EXPRESSLY LIMITS ITS LIABILITY IN THE EVENT OF A PRODUCT DEFECT TO REPAIR OR REPLACEMENT IN ACCORDANCE WITH THE TERMS OF THIS LIMITED WARRANTY AND EXCLUDES ALL LIABILITY FOR INCIDENTAL OR CONSEQUENTIAL DAMAGES, INCLUDING WITHOUT LIMITATION ANY LIABILITY FOR PRODUCTS NOT BEING AVAILABLE FOR USE OR LOST REVENUES OR PROFITS, EVEN IF IT IS MADE AWARE OF SUCH POTENTIAL DAMAGES.

**Return Policy - No returns will be accepted without prior authorization** and must include the Return Material Authorization (RMA) number. Please call and talk to one of our engineers to obtain this number at 972-575-8875.

Any product that is returned must be brand new, in excellent condition and packaged in the original manufacturer's carton with all corresponding hardware and documentation. Returns must be shipped with prepaid freight and insured via the carrier of your choice to arrive back at Portable Solar within 30 days of your initial delivery or pick-up. **Shipping charges will not be refunded.**

All returns are subject to a 35% restocking fee. **No returns will be accepted beyond 30 days of original delivery.** The value and cost of replacing any items missing (e.g. parts, manuals, etc.) will be deducted from the refund. If you have any questions regarding our return policy, please email us at [sales@sol-ark.com](mailto:sales@sol-ark.com) or call us at the number above during regular (M-F) business hours.

## Troubleshooting Guide

- **LCD is not powering on**
  - Check all connections
    - At least one of the following power sources is required: PV/Grid/Battery
  - Try pressing the power button. Or touchscreen or navigation button.
- **Panels are connected but DC Light is not on**
  - PV voltage must be 150V-500V
  - It's night
- **Panels are not producing**
  - Check all solar panel connections are wired properly
  - Turn on PV disconnect
  - Check that the PV input voltage is not greater than 500V
  - If system says PV=0V, check PV polarity
- **Panels are not producing much power**
  - PV Wire Strip Length: 5/8"
- **System not keeping batteries charged**
  - Check the charge setting in the Charge Menu
- **Auto Gen-Start not working**
  - Check to make sure your generator is compatible with Auto Start
  - Make sure that the Auto Gen Start wire is connected properly to the Sol-Ark 8K and the generator
- **Normal LED isn't on**
  - Sol-Ark 8K is not working properly (Call us)
- **Alarm Light is on**
  - Check the system alarms menu to see which alarm has been triggered
- **Grid HM value is negative when it should be positive (only applies in limited home mode)**
  - Limiter Sensors are installed backwards or L1/L2 sensors are swapped or L1/L2 sensors mis-wired
- **AC Overload Fault**
  - Check Transfer Switch/Subpanel wiring
  - Check for large loads that pull more than the inverter is rated for (EX: AC units over 4 tons)
- **DC Overload Fault**
  - Check PV voltage
  - Make sure you have not wired more than 2 solar stings in parallel
- **System is beeping**
  - Check the system alarms menu to see which alarm has been triggered. Most alarms will self-reset.
  - There is no battery connected. If not using a battery, select no battery in the setup Batt menu.
- **Battery cable is sparking when connected**
  - Use included resistor to connect the batteries (for the first time) to charge inverter capacitors before fully connecting to batteries (see installation guide)
- **Battery symbol on home screen is red**
  - Battery is under voltage or over voltage
- **Battery symbol on home screen is yellow**
  - Battery is low or charge/discharge current is close to the programmed limit (which is ok)
- **Grid symbol on home screen is yellow**
  - Grid parameters are out of specified range or grid is down
- **System has restarted**
  - Happens if: System is overloaded, Battery voltage is greater than 61V, or Software update
- **Batteries were connected backwards**
  - Battery fuse has blown (Call us)
- **Why is LCD screen still on when power button is off?**
  - If PV or Grid power, LCD stays on but inverter and loads are off.
- **The Batt % meter is not reaching 100%**
  - System needs to go through a small discharge/charge cycle to first calibrate battery
- **Generator setup is reading 0Hz**
  - Turn off UL1741. Then widen the voltage range to 53Hz-65Hz
- **Color Touchscreen is Frozen**
  - Press and hold the escape button [←] for 7-10 seconds

## Sol-Ark 8K Error Codes

Fault information	Instruction	Common Cause/Remedy
F01	DC_Inversed_Failure	Battery Input Polarity is reversed, Turn off system & correct
F02	DC_Insulation_Failure	Check DC wiring for damage to the insulation
F03	GFDI_Failure	Ground Fault, check wiring
F04	GFDI_Ground_Failure	Ground Fault, check wiring
F05	EEPROM_Read_Failure	Contact Sol-Ark.com
F06	EEPROM_Write_Failure	Contact Sol-Ark.com
F07	GFDI_Fuse_Failure	Ground fault, check wiring
F08	GFDI_Relay_Failure	Contact Sol-Ark.com
F09	IGBT_Failure	Contact Sol-Ark.com
F10	AuxPowerBoard_Failure	Contact Sol-Ark.com
F11	AC_MainContactor_Failure	Contact Sol-Ark.com
F12	AC_SlaveContactor_Failure	Contact Sol-Ark.com
F13	Working_Mode_change	Can happen when not using batteries
F14	DC_OverCurr_Failure	Usually caused by Loads that are too large (ex: 5 Ton AC Unit)
F15	AC_OverCurr_Failure	Usually caused by Appliances that are too large
F16	GFCI_Failure	Ground fault, check wiring
F17	Tz_COM_OC_Fault	Contact Sol-Ark.com
F18	Tz_Ac_OverCurr_Fault	Overloaded the Load Output, reduce loads. Wiring Short on the AC Side can also cause this error.
F19	Tz_Integ_Fault	Contact Sol-Ark.com
F20	Tz_Dc_OverCurr_Fault	Usually caused by Loads that are too large (ex: 5 Ton AC Unit)
F21	Tz_GFDI_OC_Fault	Contact Sol-Ark.com
F22	Tz_EmergStop_Fault	Contact Sol-Ark.com
F23	Tz_GFCI_OC_Fault	Contact Sol-Ark.com
F24	DC_Insulation_Fault	Contact Sol-Ark.com
F25	DC_Feedback_Fault	Contact Sol-Ark.com
F26	BusUnbalance_Fault	Too much load one leg (L1 or L2) Vs the other leg
F27	DC_Insulation_ISO_Fault	Contact Sol-Ark.com
F28	DCIOver_M1_Fault	Contact Sol-Ark.com
F29	AC_AirSwitch_Fault	Contact Sol-Ark.com
F30	AC_MainContactor_Fault	Contact Sol-Ark.com
F31	AC_SlaveContactor_Fault	Contact Sol-Ark.com
F32	DCIOver_M2_Fault	Contact Sol-Ark.com
F33	AC_OverCurr_Fault	Usually caused by Loads that are too large
F34	AC_Overload_Fault	Usually caused by Loads that are too large
F35	AC_NoUtility_Fault	Contact Sol-Ark.com
F36	AC_GridPhaseSeque_Fault	Contact Sol-Ark.com
F37	AC_Volt_Unbalance_Fault	Contact Sol-Ark.com
F38	AC_Curr_Unbalance_Fault	Contact Sol-Ark.com
F39	INT_AC_OverCurr_Fault	Contact Sol-Ark.com

F40	INT_DC_OverCurr_Fault	Contact Sol-Ark.com
F41	AC_WU_OverVolt_Fault	Contact Sol-Ark.com
F42	AC_WU_UnderVolt_Fault	Contact Sol-Ark.com
F43	AC_VW_OverVolt_Fault	Contact Sol-Ark.com
F44	AC_VW_UnderVolt_Fault	Contact Sol-Ark.com
F45	AC_UV_OverVolt_Fault	Contact Sol-Ark.com
F46	AC_UV_UnderVolt_Fault	No Battery and PV Disconnect is Turned OFF
F47	AC_OverFreq_Fault	Contact Sol-Ark.com
F48	AC_UnderFreq_Fault	Contact Sol-Ark.com
F49	AC_U_GridCurr_DcHigh_Fault	Contact Sol-Ark.com
F50	AC_V_GridCurr_DcHigh_Fault	Contact Sol-Ark.com
F51	AC_W_GridCurr_DcHigh_Fault	Contact Sol-Ark.com
F52	AC_A_InductCurr_DcHigh_Fault	Contact Sol-Ark.com
F53	AC_B_InductCurr_DcHigh_Fault	Contact Sol-Ark.com
F54	AC_C_InductCurr_DcHigh_Fault	Contact Sol-Ark.com
F55	DC_VoltHigh_Fault	Check battery voltage, should not be above 59V
F56	DC_VoltLow_Fault	Batteries are overly discharged
F57	AC_BackFeed_Fault	Contact Sol-Ark.com
F58	AC_U_GridCurr_High_Fault	Contact Sol-Ark.com
F59	AC_V_GridCurr_High_Fault	Contact Sol-Ark.com
F60	AC_W_GridCurr_High_Fault	Contact Sol-Ark.com
F61	AC_A_InductCurr_High_Fault	Contact Sol-Ark.com
F62	AC_B_InductCurr_High_Fault	Contact Sol-Ark.com
F63	ARC_Fault	Can be a false alarm or bad PV connection
F64	Heatsink_HighTemp_Fault	Check the built-in fans, ambient temp may be to high

# Sol-Ark 8K Install Operational Verification

**Installer to complete after system is working. This protects installer, home owner, and inverter.**

1. Is the 8K installed in a location protected from water and has 6" clearance left and right for cooling? **Y/N**
2. Are all the battery lugs tightened? **Y/N**
3. 8K should be connected to Grid, 8K 50A load/Grid breakers on, batteries connected, PV input on and ON button on. Leaving all 10 transfer switches on Line/Grid, test circuit only one at a time to Gen/Solar and then back to Line. Wiring should be correct if you do all 10 to verify no breakers pop or inverter overload.
  - a. Did any breakers trip? **Y/N**
  - b. Did inverter overload? **Y/N**
  - c. Set all switches to Gen/Solar.

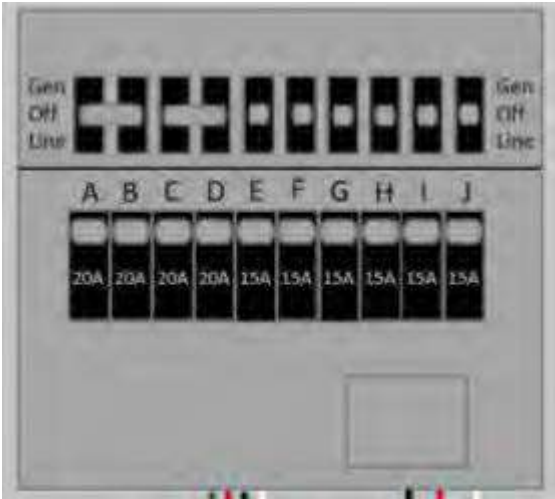

- d.
4. If you have problems, please take pictures of these: (Email to sales@Sol-Ark.com)
  - a. **Battery icon screen, showing detailed voltages (the screen shown below)**
  - b. **Sol-Ark 8K with batteries and of user wiring area**
5. Load and solar test
  - a. Did you do this entire section with the customer to explain the home screen and the detailed voltages screen? **Y/N**
  - b. Press the battery icon for the detailed voltages screen.
  - c. Is batt temp sensor working? **Y/N**
  - d. Turn on many loads for the critical circuits. Are solar panels producing enough power to match the load (provided there is enough sun)? **Y/N**
  - e. **Verify** screen in limited power to loads mode (default). Are both Grid Home measurements positive? **Y/N**

In Limited to home Mode HM values will be close to zero. HM values should never be negative. If negative, the Limiter Sensors are not installed properly.

Solar	Grid	INV	Load	Batt
0W	0W 50.0Hz	0W 50.0Hz	0W	68W 87%
L1: 0V 0.0A	117V HM: 0W	118V 0.2A	118V	51.13V 1.36A
0W	LD: 0W	0W	0W	0.0C
L2: 0V 0.0A	117V HM: 0W	118V 0.2A	118V	DC: 50.1C AC: 40.3C
0W	LD: 0W	0W	0W	

f.

- g. Program Full Grid sell mode. If there are enough panels and sun or light loads in the entire house, the Grid HM measurements will be negative on both L1/L2. Are they negative (solar selling back to grid)? **Y/N**
  - h. Program limited power to home mode. The Grid HM sensors will be near zero or slightly positive. Are they both near zero and cancelling out the whole home power? **Y/N**
  - i. You have verified the limit sensors are correctly installed. Program in the correct Grid mode the customer will use.
6. Did you program the correct Ah for battery bank and ~20% max Amps charge/discharge? **Y/N**
  7. Did you program the correct battery charge voltages for your battery type? **Y/N**
  8. Turn off the AC breaker so 8K is operating in off grid mode for several minutes. Are appliances still powered? **Y/N**
  9. Turn off PV input, running only on batteries for several minutes. Are appliances still powered? **Y/N**
  10. Turn on PV input and AC Grid inputs.
  11. Did you setup Wi-Fi plug to the customer's internet? **Y/N**
  12. Absolutely important for software updates. Did you help customer register system on Monitoring App? **Y/N**
  13. Does customer have a 3-10KW standby generator or small generator? **Y/N**
    - a. Did you turn off UL1741/IEEE1547 and reprogram grid freq range to 53-65Hz? **Y/N**
    - b. If standby generator, are the current limit sensors on the Grid side of the generator transfer switch? **Y/N**
    - c. If small gas generator using Gen inputs, did you enable Gen charging and properly set charge current? **Y/N**
  14. If EMP protected, did you install EMP Suppressors on critical appliance cords? **Y/N**

\_\_\_\_\_  
 Installer Name

\_\_\_\_\_  
 Installer Signature

\_\_\_\_\_  
 Date

\_\_\_\_\_  
 Customer Name

\_\_\_\_\_  
 Customer Signature

\_\_\_\_\_  
 Date