



How to Sell and Design Lithium Energy Storage

Topic

- Why Energy Storage
- Company Introduction
- Battery Technology Comparison
- Compatible Inverters
- Design Guide for PV + Storage



Why Energy Storage

US Energy Storage Market

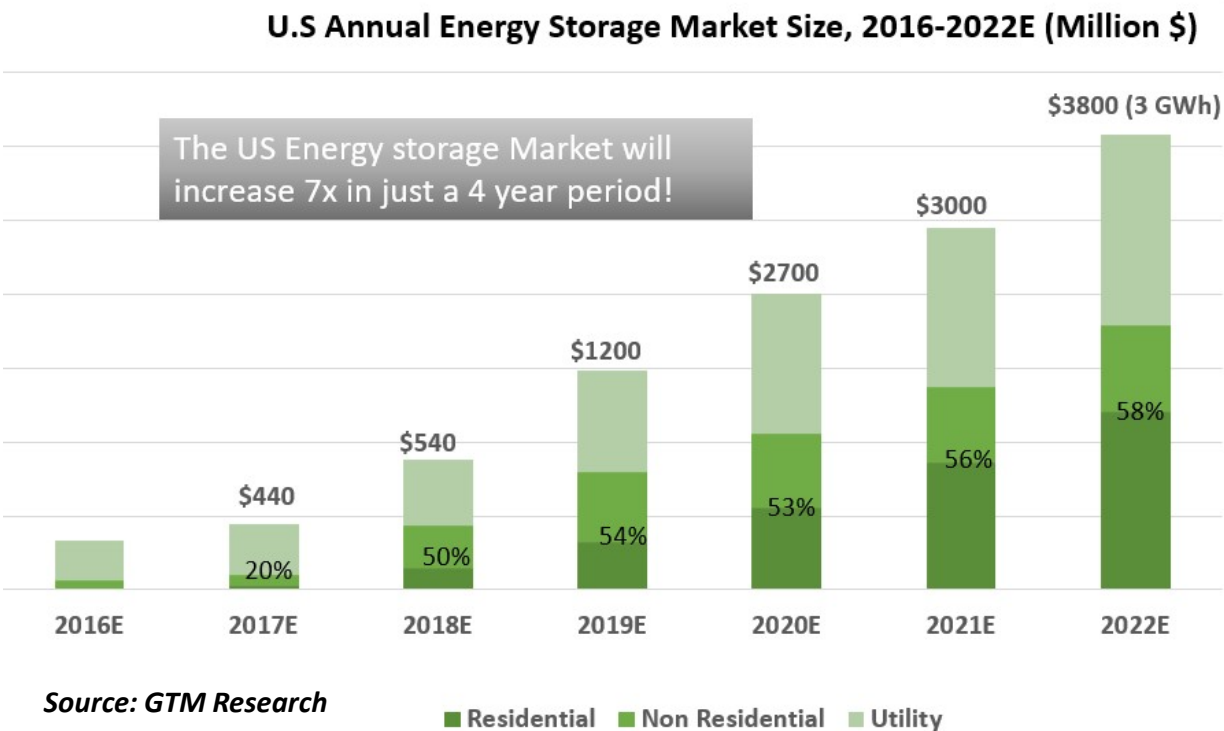

Central & Latin America Energy Storage Market

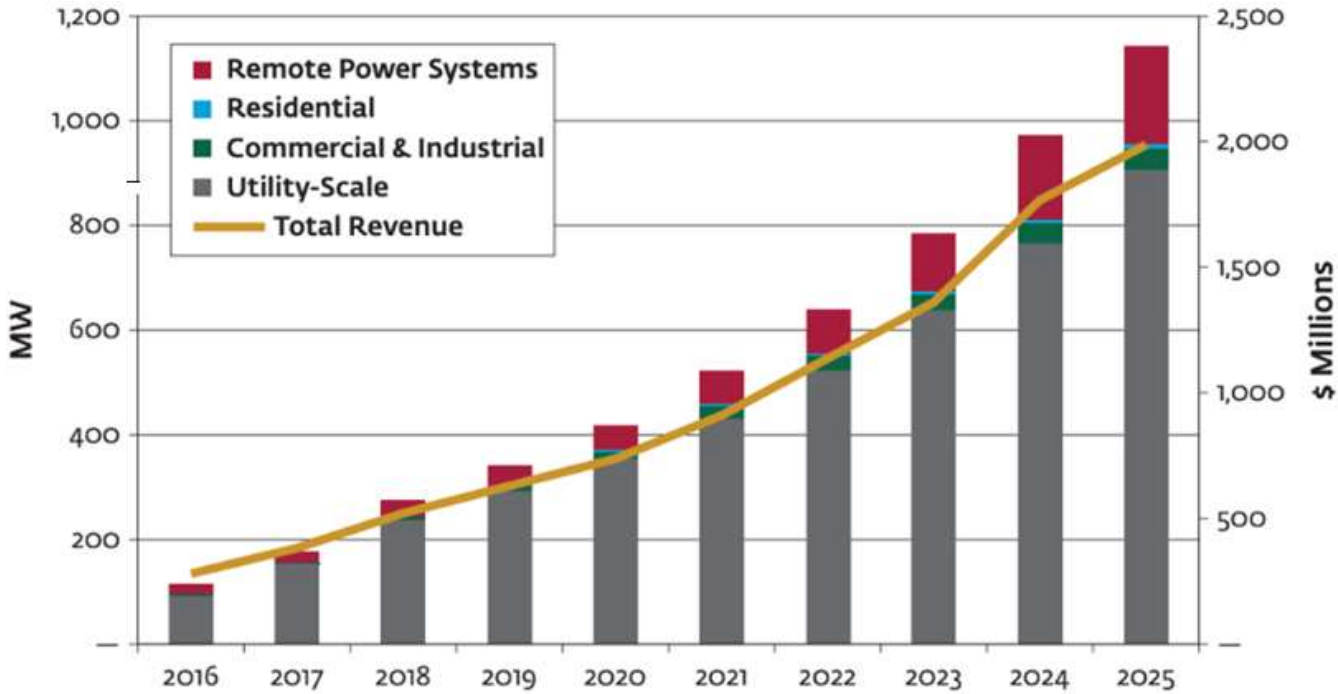

Annual stationary Energy Storage Deployments by Segments Central & Latin America, (2016-2025); Source IFC ES Report

Energy Storage Benefits

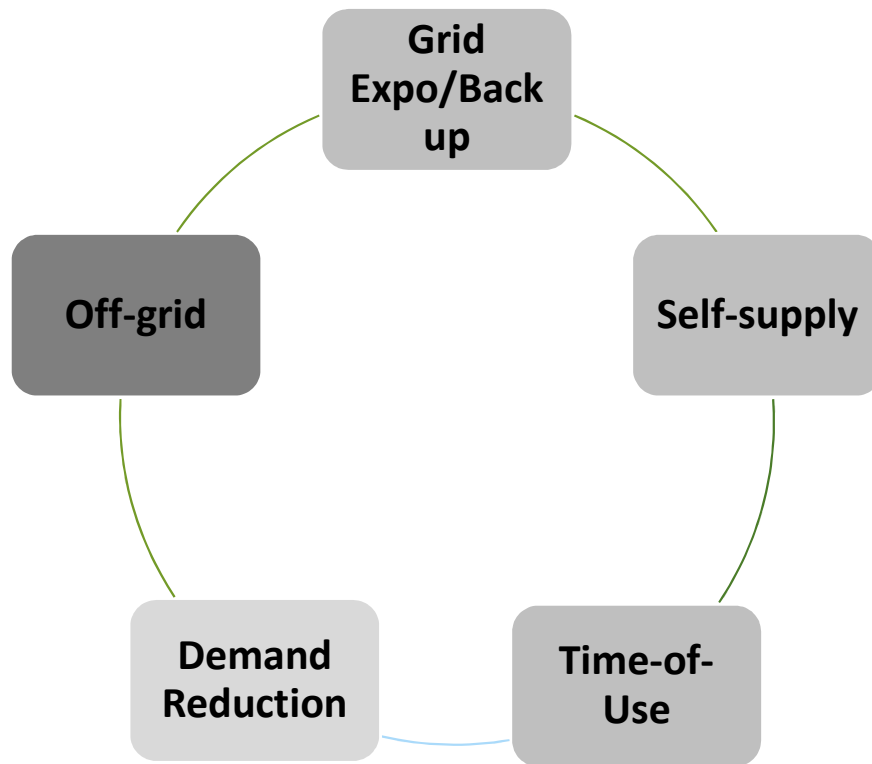

Back Up Your Facility

Power your facility when the grid is off; keep solar panels running during outages. Run Generators more efficiently



Allows "Self Supply"

Install PV where grid prohibits back feed



Maximize Your PV Production

Store excess solar power for later use.



Save Money on your Electric Bill

Charge the batteries at off-peak times; discharge them during peak periods. Peak Shaving to lower demand.



Tax and Incentives

30% ITC available if it's powered by solar; enjoy state and utilities rebates

Off-Grid Application

Stand alone PV + Storage System

- a) No grid available. Power loads from PV or Battery
- a) Integrate generator, if needed

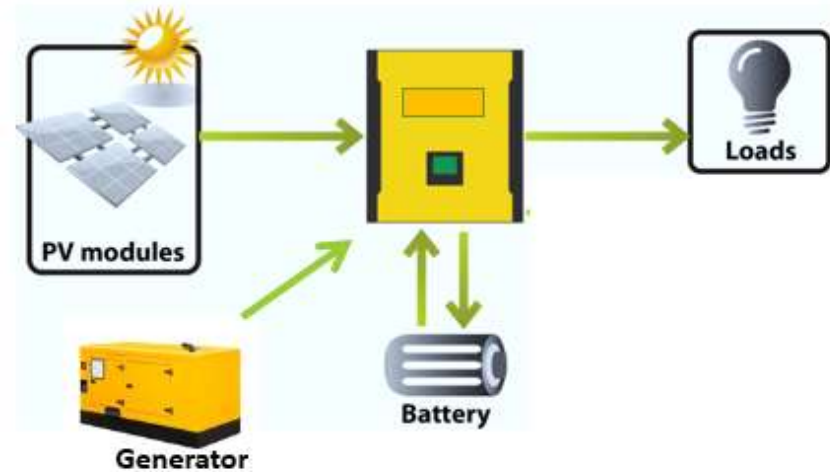

Grid Interactive Applications (Why Battery Back-Up?)

Grid Export / Back up / Time-of-Use / Demand Reduction

- a) When grid fails, Inverter powers loads from PV or Battery.
- b) Inverter Priority: Flexible from keeping batteries charged to maximizing \$ savings to minimizing grid interaction.
- c) Peak Shaving of Grid Power (save demand \$).
- d) Block out times for purchasing grid power (ie. high tariff times) and re-charge batteries at low-cost times.

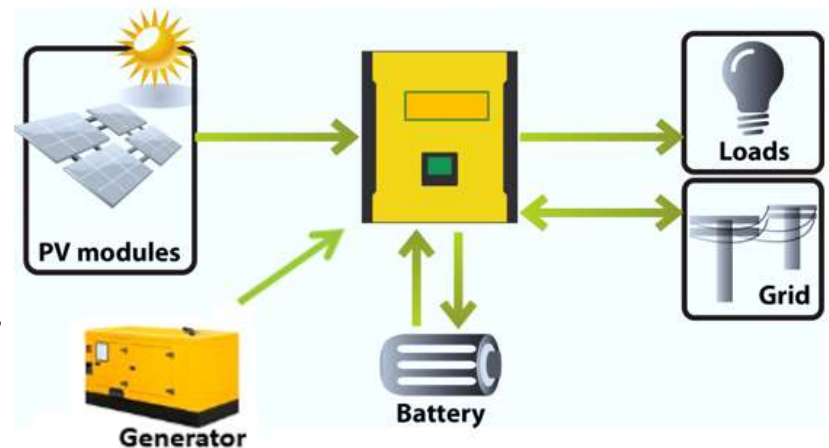

Grid Interactive Applications

Self-Supply Application (HI, CA, NY, Caribbean)

- a) Grid Available for Purchase but Sale is prohibited
- b) PV power charges batteries during day and discharges them at night.
- c) When Battery Charge low, power bought from grid to supply loads and/or charge batteries.

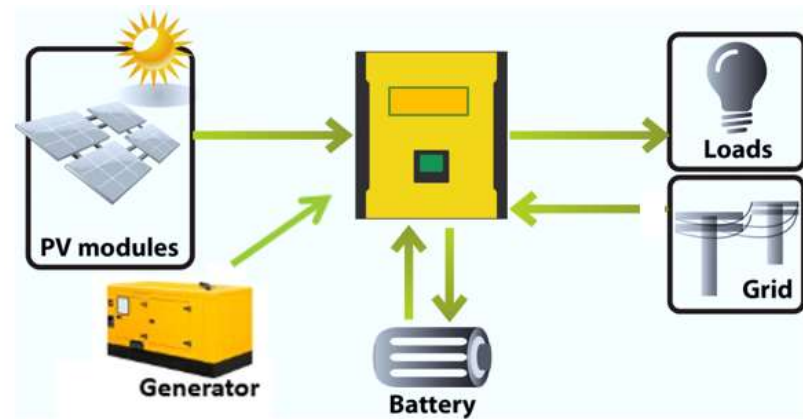



Company Introduction



US Headquarter

A world-leading manufacturer who brings automotive Lithium Ferro Phosphate batteries to the energy sector

- ❑ U.S. Headquarter: Southampton, PA
- ❑ 30,000 Sqf Facility for R&D, Sales and Logistic
- ❑ Logistic Centers in California and Florida
- ❑ Over 35 MWH Installs Worldwide
- ❑ Exclusive Battery Supplier for a local railway company



Manufacturing Facility



- ❑ Manufacturing Facility in Shenzhen, China
- ❑ ISO and OHSAS Certified
- ❑ Produce Lithium Batteries since 2008
- ❑ Supply Batteries to Automotive Companies
- ❑ 800 MWH Production Capacity

Fortress Lithium Iron Phosphate Batteries

eVault 18.5 kWh



LFP-10 kWh



LFP-5 kWh



Battery Management System (BMS)

Multilevel Safety Concept for Highest Reliability

- ✓ Voltage and Temperature Monitoring
- ✓ Overcharge and Deep Discharge Protection
- ✓ Over-heat Protection
- ✓ Over Current Protection (DC Breaker)
- ✓ Cell Monitoring and Balancing

eVault LCD Display

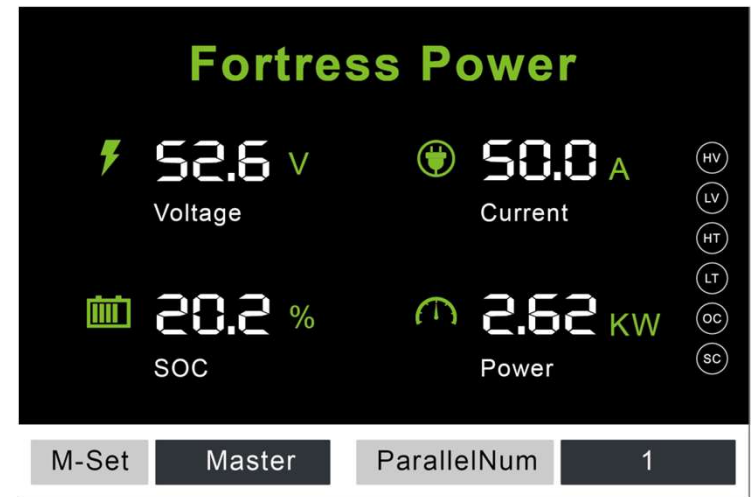

Technical Specification

	eVault 18.5	LFP-10	LFP-5
Total Energy [KWH]	18.5	10.2	5.1
Capacity [AH]	360	200	100
Battery Voltage [V]	48V		
Max. Charge Current (Continuous) [A]	160	80	80
Max Discharge Power (Continuous) [KW]	9 (180A)	5 (100A)	4 (80A)
Peak Output [KW]	12 (240A)	7.5 (150A)	7.5 (150A)
Parallel Stacking	12	2	2
LCD Monitoring	Yes	No	No
Communication	CAN/RS485	N/A	N/A
Breaker	250A	150A	125A
Warranty	5/10 years; up-to 6,000 cycles		

Battery Technology Comparison

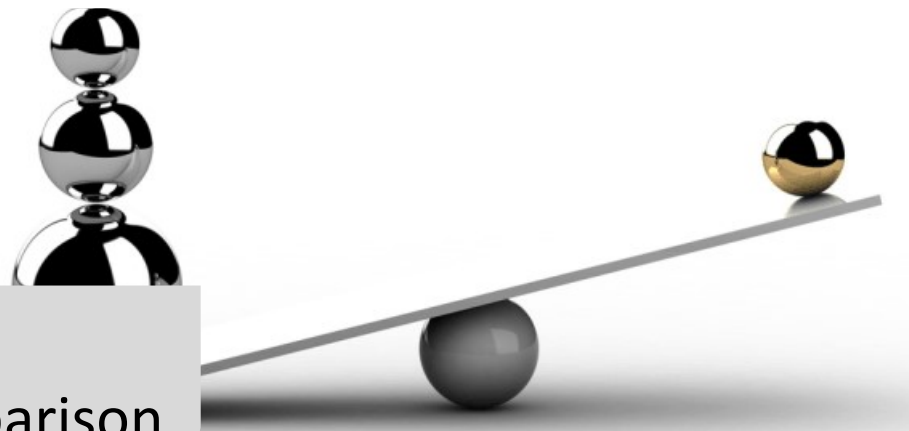

LFP vs NMC vs LiPo

We incorporate the safest technology available into our batteries

	Fortress Power	Tesla, LG Chem, Panasonic	Humless
Chemistry	Lithium Ferro/Iron Phosphate (LFP) or LiFePo4	Lithium Ion or Nickel- Magnesium - Cobalt (NMC)	Lithium Polymer or LiPo
Safety	✓	X	X
Eco-friendly	✓	X	X
Thermal Stability	✓	X	X
Life Cycles	6000	< 3000	< 1500
Degradation Rate		LFP < NMC < LiPo	
Energy density		LFP < NMC < LiPo	

Highest Safety Standard



Lithium Iron Phosphate Technology (Fortress Power)

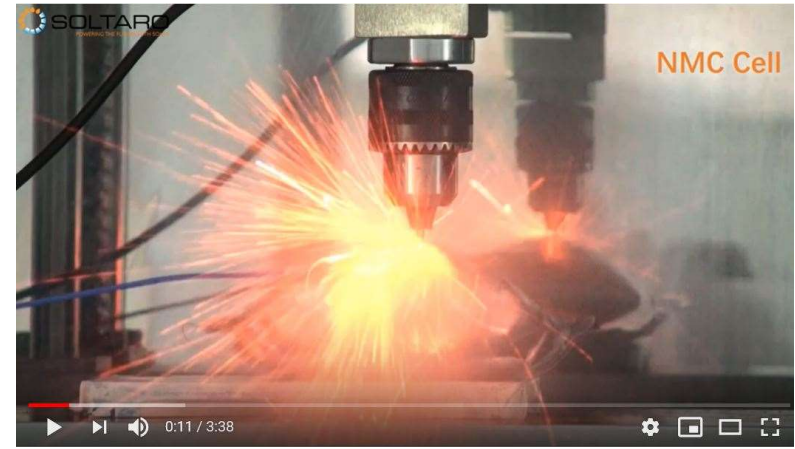

Nickel-Manganese-Cobalt Technology (Tesla)

View [LFP vs. NMC nail test video](#) on YouTube

Performance Comparison: LFP vs. Lead Acid (Nameplate Capacity is not the same)

LFP vs Lead Acid at various discharge rate

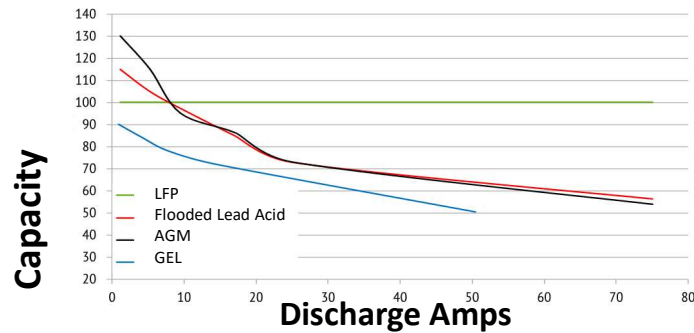

LFP is less affected by Temperature

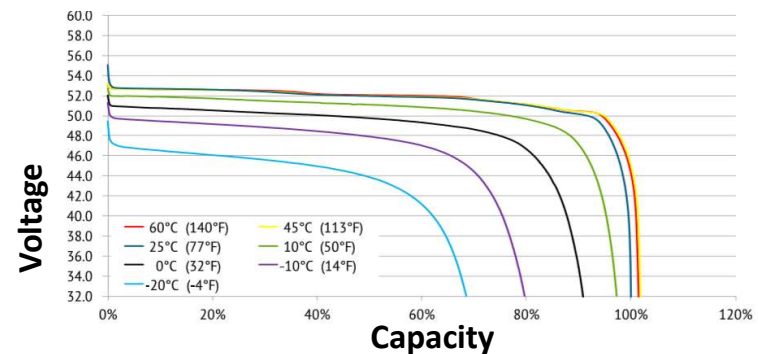

LFP Advantages:

- a) LFP Actual Capacity = Nameplate Capacity
- b) Lead Acid allows only 50% DoD, Actual Capacity = 0.5*Nameplate Capacity
- c) Lead Acid Capacity is affected by Discharge Rate, Temperature, and DoD at much higher rates than LFP.

LFP Cycle Life in Relation to Depth of Discharge (DoD)



Comparison of different Battery Technologies

	LFP	Lithium Ion	Li-Polymer	Flooded LA	AGM	Nickel Iron
Round trip efficiency	98%	95%	95%	80%	88%	65%
The Homeowner Cost of 10 kWh	6,900	6,500	4,500	1,200	2,200	18,000
Cycle Life @ 80% DOD	6,000	2,800	1,500	300	500	8,000
Off Grid Years	16.4	6.8	4	1	1.4	21.9
Energy Throughput in MWH	47	21.5	11.5	1.9	3.5	41.6
Cost per kWh	0.14	0.30	0.40	0.74	0.57	0.19
Safety	Yes	No	No	No	No	Yes
Free Maintenance	Yes	Yes	Yes	No	Yes	No

Energy Throughput: The total amount of energy a battery can be expected to store and deliver over its lifetime

Comparison Chart of Various Lithium Batteries

	Fortress Power	Simpliphi	Discover	LG Chem	Panasonic
Battery Chemistry	LFP	LFP	LFP	NMC	NMC
Safety	Y	Y	Y	N	N
Usable Power	10/18.5 kWh	2.5/3.5 kWh	6.6 kWh	9.3 kWh	2 kWh
Roundtrip efficiency	98%	98%	98%	94.5%	96.5%
LCD Display	Yes	No	No	No	No
Guaranteed Battery Cycles	6,000	10,000	5,000	2,500	2,800
Off-Grid years	16	27 **	13.6	6.8	7.7
Price per kWh	Low	High	High	Low	Low
Installation time	Low	High	High	Low	High
Cost per kWh	Lowest	Mid	Mid	High	High

** Simpliphi uses low-cost MOSFET based BMS, which only lasts 10-15 years.

Space Comparison: LFP is 1/3 size and 1/3 weight of AGM



AGM Batteries
48V, 250AH
(6 kWh usable power)

Fortress eVault
48V, 360AH (16.5
kWh usable power)

LFP Technology Advantage



Superior Safety



High Throughput



Long Duration



Low Energy Cost

Inverter Comparison



AC vs DC Coupled Solution

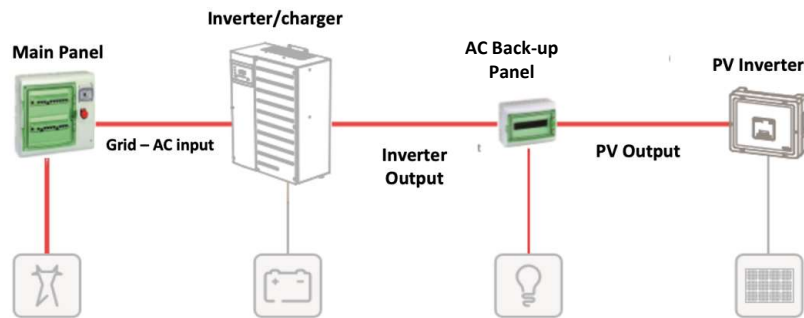

AC-Coupled System Diagram

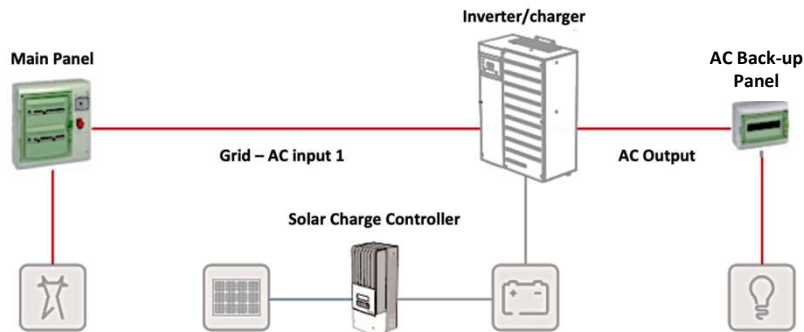

DC-Coupled System Diagram

Application for AC coupled solutions

- *When retrofitting to existing PV systems*
- *For new installations that require module level rapid shutdown*

Application for DC coupled solutions

- *For new installation*
- *No additional PV inverter*
- *More efficient*

Compatible Inverters

COMPATIBLE WITH MOST 48V CHARGERS AND HYBRID INVERTERS!

Brand	Inverter/Charger Mode	Configuration
Schneider	Conext XW MPPT charge controller; Conext XW+ series; Conext SW;	AC or DC coupled
Outback	Skybox, FLEX max charge controller (48V), FLEXpower series (48V); Radian series (48V); FXR(A) and FXR (E) series (48V); GVFX and GVFX series (48V);	AC or DC coupled
Magnum	MS 4448PAE; MS 4048-20B	AC or DC coupled
SMA**	SUNNY ISLAND 4548-US/6048-US; SUNNY ISLAND 3.0M/4.4M/6.0H/8.0H	AC coupled
Sol-Ark**	8 KW Inverter	AC or DC coupled
Victron	Phoenix VE.Direct Inverter; MultiPlus and Quattro Inverter/Charger; Skylla-TG Charger; General; Color Control or Venus GX	DC coupled
Morning Star	TriStar MPPT 600V; TriStar MPPT; Tristar PWM	DC coupled
Midnite Solar	Solar Classic 150, 200 & 250; Solar Classic 150, 200 & 250-SL	DC coupled

** we're establishing communication with those inverters!

FORTRESS + SOL-ARK 8KW (AC & DC Coupling)



9 kW/18.5 kWh

Key features:

- *All in one unit (Off-grid, Time-of-use, Self-supply, Back-up, Grid export)*
- *Compact & easy to install*
- *Allows DC & AC coupling*
- *No transformer required*
- *The best roundtrip efficiency: 93%*
- *High surge power: 20KW*
- *Auto-Gen start included*
- *Cannot run in parallel*

Technical Specification

	Output to the Critical Load		Output to the Grid
	On Solar or Battery (Back-up)	With Grid or Generator Present	Pass-through
AC Output Power	9 KW	12 KW	12 KW
Surge power	20 kW (5 Sec)		
AC Output Voltage	120/240V		
UPS Grid Failure Transfer time	12 kW auto-transfer relay at 4ms		
PV Array in DC Coupling	Up-to 11 KW		
PV Array in AC Coupling	Up-to 7 KW		
PV Array in AC & DC Coupling combined	Total max 13 KW		
Storage capacity	10/18.5 KWH per unit; scalable to 222 KWH		

System Wiring

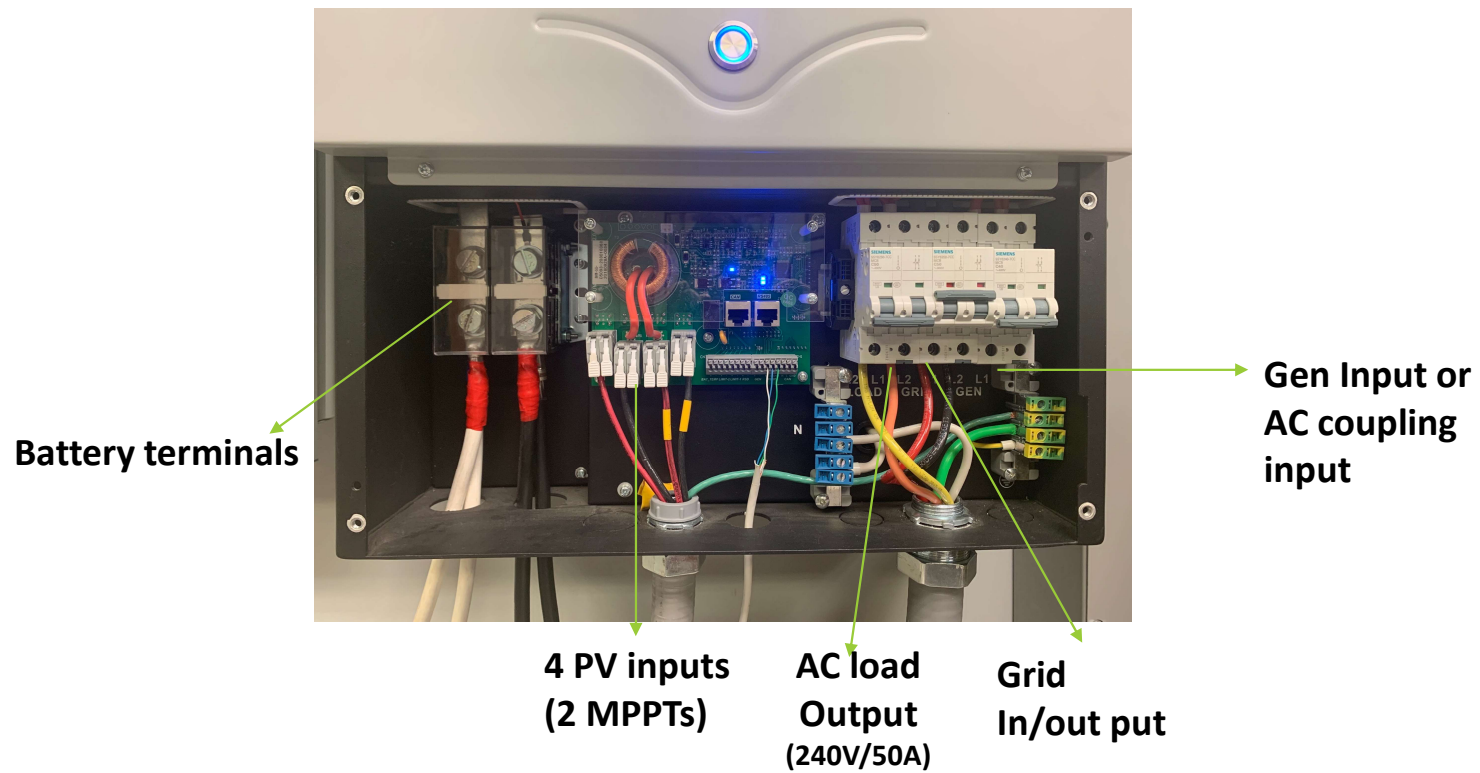

New 12KW Inverter-available in January, 2020



- ❑ Stacking up-to 3 in 120/240V
- ❑ Stacking up-to 6 in 120/280V
- ❑ 10 years warranty
- ❑ Accessible breakers

Integrating Midnite for String Level Rapid Shutdown

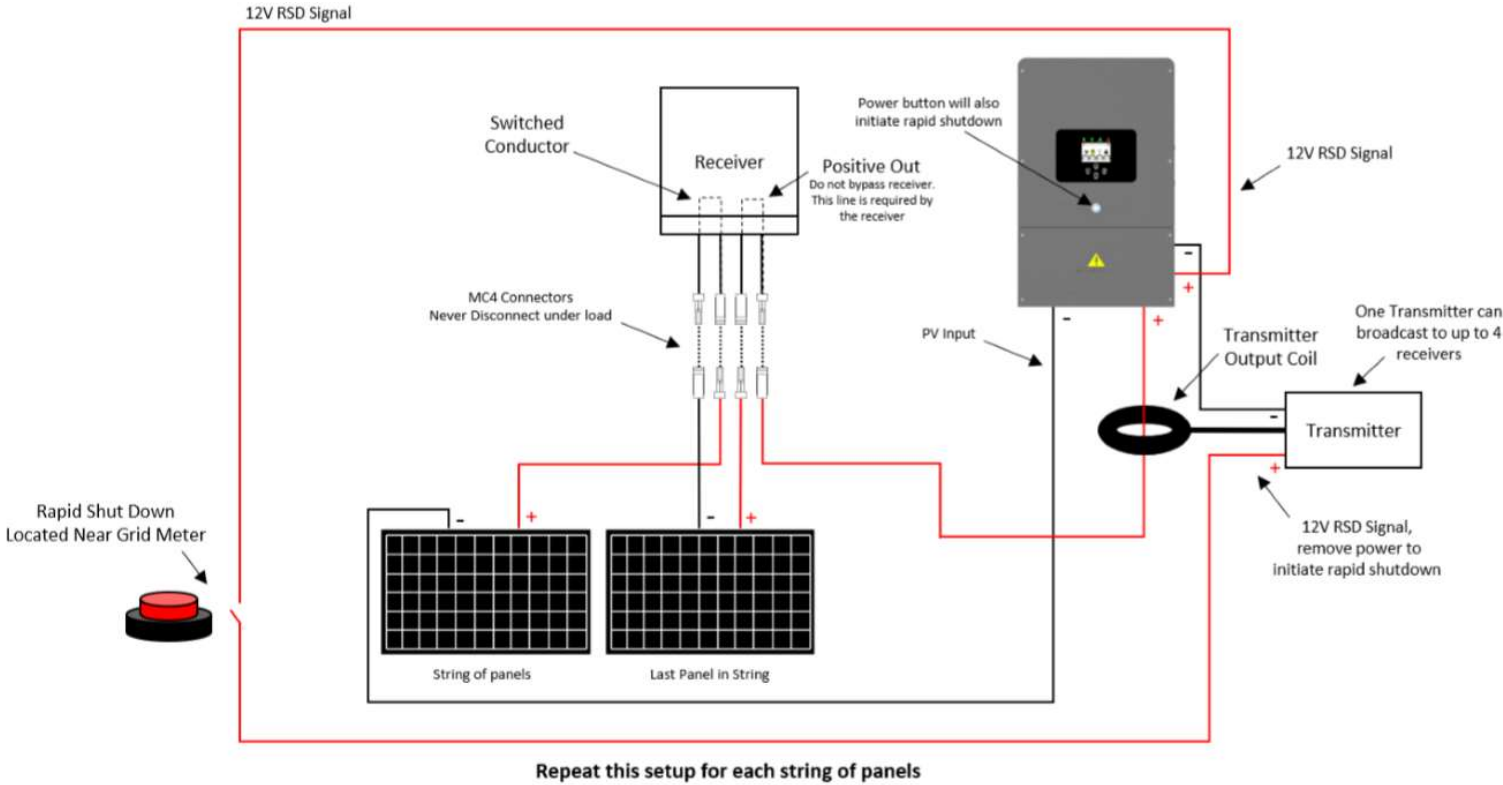

Integrating Tigo for Module Level Rapid Shutdown

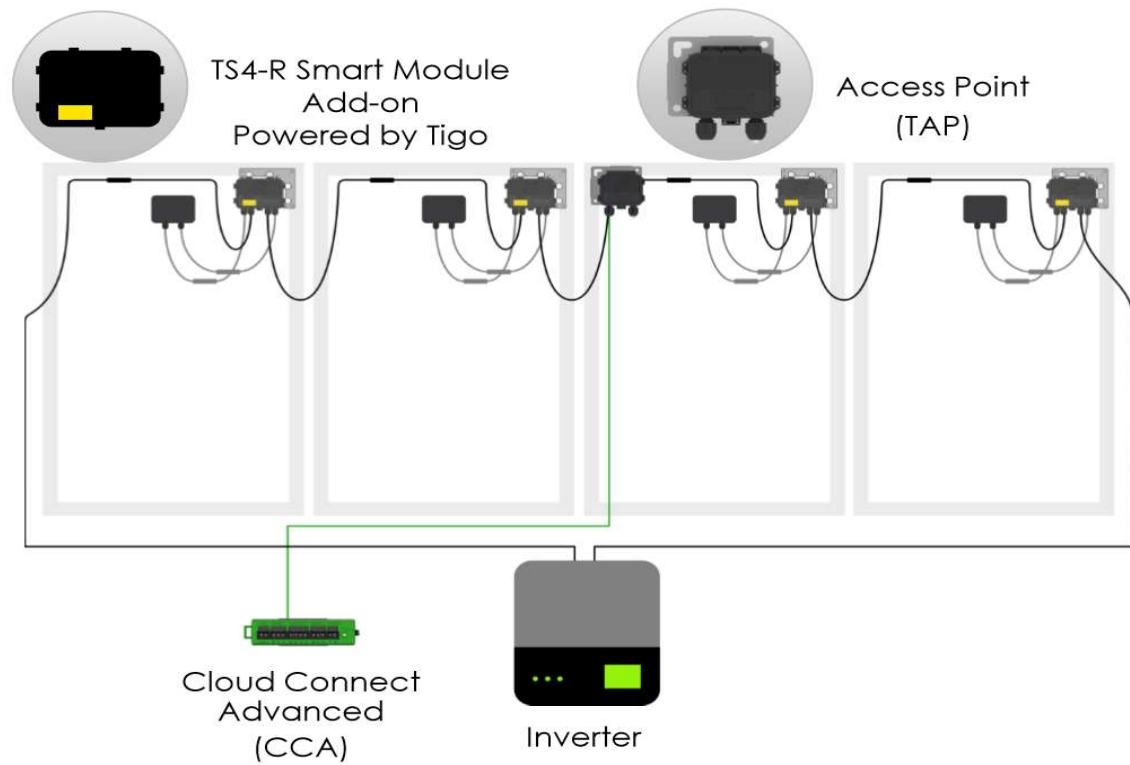



Design Guide for PV + Storage

Fortress Energy Storage Sizing Tool simplifies battery size design

Automatically size Up Energy Storage for Backup

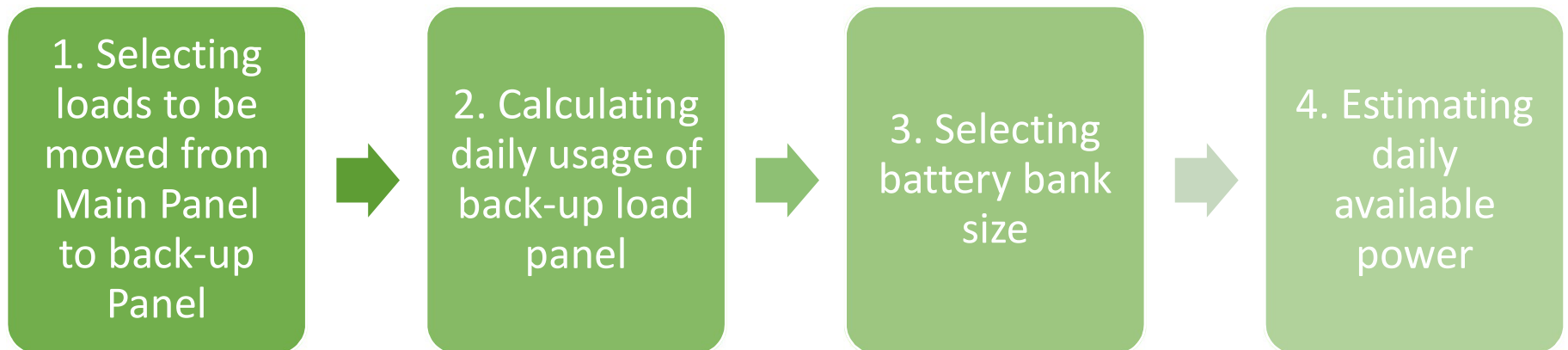

Available to our authorized installers

Fortress Energy Storage Sizing tool Example

	Category	Item	Quantity	Starting Watts	Running Watts	Hours/Day	Watthours/Day
1	Essential	Refrigerator/Freezer-Energy Star	1	1200	200	8	1600
2	Essential	Incandescent Light Bulb-60 Watt	4	240	240	4	3840
3	Essential	LED Light Bulb-60 Watt Equivalent	6	48	48	4	1152
4	Essential	Sump Pump-1/3 HP	1	1300	800	0	0
5	Essential	Water Well Pump-1/3 HP	1	1400	750	3	2250
6	Kitchen	Electric Range-6" Element	1	1500	1500	1	1500
7	Kitchen	Microwave Oven-650 Watts	1	1000	1000	0.1	100
8	Personal Electronics	TV-Flat Screen-46"	1	190	190	6	1140
9	Personal Electronics	Cell Phone Charger	1	25	25	2	50
10	Personal Electronics	Computer-Laptop	1	250	250	2	500
11	HVAC	Window AC-10,000 BTU	1	1400	1200	3	3600
12	HVAC	Furnace Fan-gas/oil-1/4 HP	1	1000	600	1	600
	STANDBY POWER	Sol-Ark 8 kW	1	60	60	24	1440
		Totals		9613	6803		17772

Inverter Type	Quantity**	Watthours/Day	Surge Power	Running Watts
Sol-Ark 8 kW	1	17772 Watts	10387 Watts Available	1197 Watts Available

Monthly PV/Day Production and Energy Available to Charge Batteries

**9 KW PV array
+
9KW/20 KWH**

	Solar Radiation	AC Energy	Energy Per Day (watthours)	Full charge on battery	avail. Energy after battery charged
January	3.8	751	24,226	(18,432)	5,794
February	4.28	746	26,643	(18,432)	8,211
March	5.23	986	31,806	(18,432)	13,374
April	5.91	1,039	34,633	(18,432)	16,201
May	6.32	1,132	36,516	(18,432)	18,084
June	6.74	1,106	36,867	(18,432)	18,435
July	6.36	1,090	35,161	(18,432)	16,729
August	5.78	1,004	32,387	(18,432)	13,955
September	5.19	886	29,533	(18,432)	11,101
October	5.08	926	29,871	(18,432)	11,439
November	4.14	749	24,967	(18,432)	6,535
December	3.38	646	20,839	(18,432)	2,407

WHAT TO EXPECT

Available power in Battery at 90% DoD	18,432 Wh	0.9 Days
Lowest average daily available PV Power:	20,800 Wh	
Highest average daily available PV Power:	36,800 Wh	

Authorized Installer Benefits

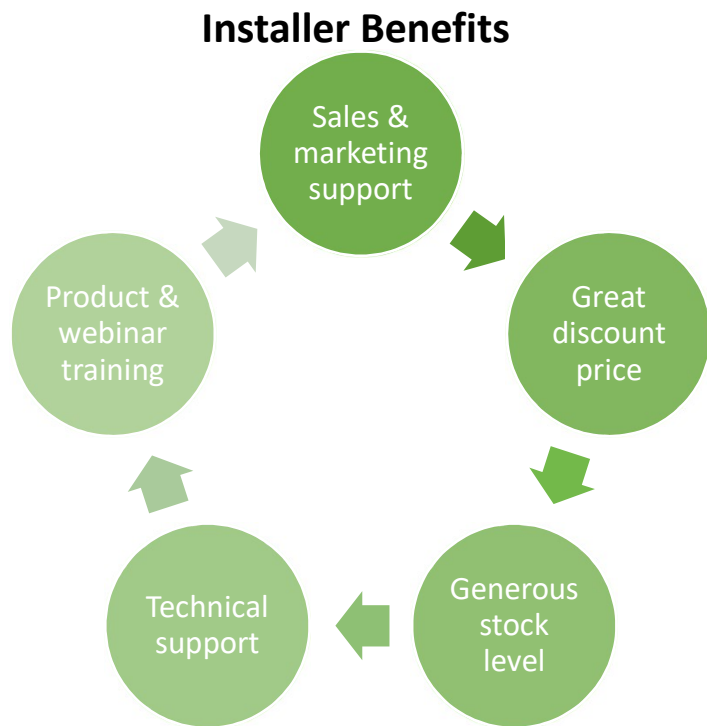

Becoming

Fortress Power
Authorized Installer



Thank You & Contact Us

**If you want to go fast, go alone;
if you want to go far, go together!**



Jing Yu

jingy@fortresspower.com

(877) 497- 6937

www.fortresspower.com

Tim Tuttle

t.tuttle@usa.krannich-solar.com

(856) 266-9911

www.usa.krannich-solar.com