



How To Set Up Fortress Power Lithium Batteries Using Sol-Ark Inverter

Table of Contents

Table of Contents.....	1
Introduction	1
Parameter settings for Fortress batteries with Sol-Ark 8/12kW	2
Setting up closed-loop communication between eFlex 5.4 and Sol-ark.....	3
Making the modified RJ45 cable.....	3
Connecting the eFlex to the Sol-ark inverter	3
Appendix	5
Exhibit A	5
Exhibit B	5
Exhibit C	6
Exhibit D	6
Exhibit E.....	7

Introduction

This integration guide will help set up the charge/discharge parameters of Fortress Power batteries as they relate to Sol-ark inverters, as well as the setup of closed-loop communication between the eFlex 5.4 and the Sol-ark. For any additional help, please contact techsupport@fortresspower.com

How To Set Up Fortress Power Lithium Batteries Using Sol-Ark Inverter

Parameter settings for Fortress batteries with Sol-Ark 8/12kW

Battery		
	80% DoD, 6000 cycles	90% DoD, 3000 cycles
Battery Capacity	eFlex: 105AH per battery LFP-10: 200AH per battery eVault : 360AH per battery	
Max A Charge Rate	eFlex:55A per battery LFP-10: 50A per battery eVault:100A per battery	eFlex: 60A per battery LFP-10: 80A per battery eVault:150A per battery
Max A Discharge Rate	eFlex: 100A per battery LFP-10: 100A per battery eVault: 160A per battery	
TEMPCO	0	
Use Battery charged	Select	
Use Batt % charged	-	
No Battery	-	
BMS Lithium Batt 01	-	
Active Battery	-	
Charge		
Start V	51.7V / 30%	
A	eFlex:55A per battery LFP-10: 50A per battery eVault:100A per battery	eFlex:60A per battery LFP-10: 80A per battery eVault:150A per battery
Float V	54.4 V	
Absorption V	54.4 V	54.6 V
Equalization V*	55.5	
	30 days	
	0 hours	
Discharge		
Shutdown	51.4V / 20%	
Low Batt	51.7V / 30%	50.7V / 10%
Restart	51.9V / 25%	
Batt Resistance	5mOhms	
Batt Charge Efficiency	98%	



Please reassess capacity and charge/discharge current settings, when Fortress battery quantities change.

How To Set Up Fortress Power Lithium Batteries Using Sol-Ark Inverter

Setting up closed-loop communication between eFlex 5.4 and Sol-ark

All Fortress Power batteries work in open-loop communication mode—that is, with voltage detection. However, closed-loop communication between the eFlex 5.4 and the Sol-ark inverter improves the efficiency of a lithium battery. The following is a guide to setting up closed-loop communication between the eFlex 5.4 and the Sol-ark inverter

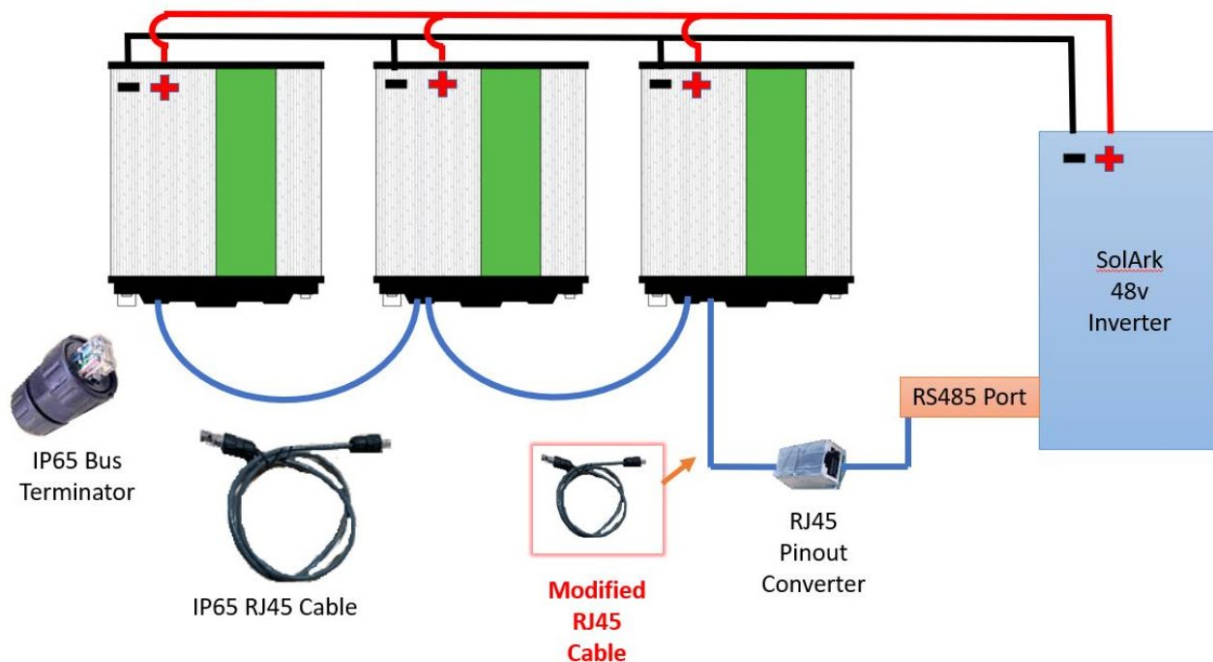

Making the modified RJ45 cable

A **modified RJ45 cable** must be made to ensure proper communication to the Sol-ark inverter. Cut into an ethernet cable, cutting through all wires except pins 7+8 (**brown-white and brown**) as shown in Appendix B. This will disable all eFlex → Sol-ark communication except the RS485 A+B inputs. Use electrical tape on the cut portion of the RJ45 cable to ensure a stable connection.

Connecting the eFlex to the Sol-ark inverter

Connect the modified RJ45 cable into the eFlex (Exhibit A) and then into the RJ45 pinout converter. Using another RJ45 cable, connect the pinout converter to the RS485 port in the Sol-ark (Exhibit B).

Power on the eFlex and Sol-ark as usual and navigate to the “battery setup” menu on the Sol-ark. Next, check the “Use Batt % charged” box as well as the “BMS Lithium Batt” box and set it to “04” (Exhibit D).



How To Set Up Fortress Power Lithium Batteries Using Sol-Ark Inverter

If the communication is successful, a new menu option should open in the battery monitoring page and the screen that appears should show a table of detailed battery information (Exhibit E) for each battery connected.

This data can also be monitored remotely using Sol-ark's monitoring software and wifi module. For remote monitoring using Sol-ark the wifi module, please refer to the guide on the Sol-ark website.

How To Set Up Fortress Power Lithium Batteries Using Sol-Ark Inverter

Appendix

Exhibit A



Exhibit B



How To Set Up Fortress Power Lithium Batteries Using Sol-Ark Inverter

Exhibit C

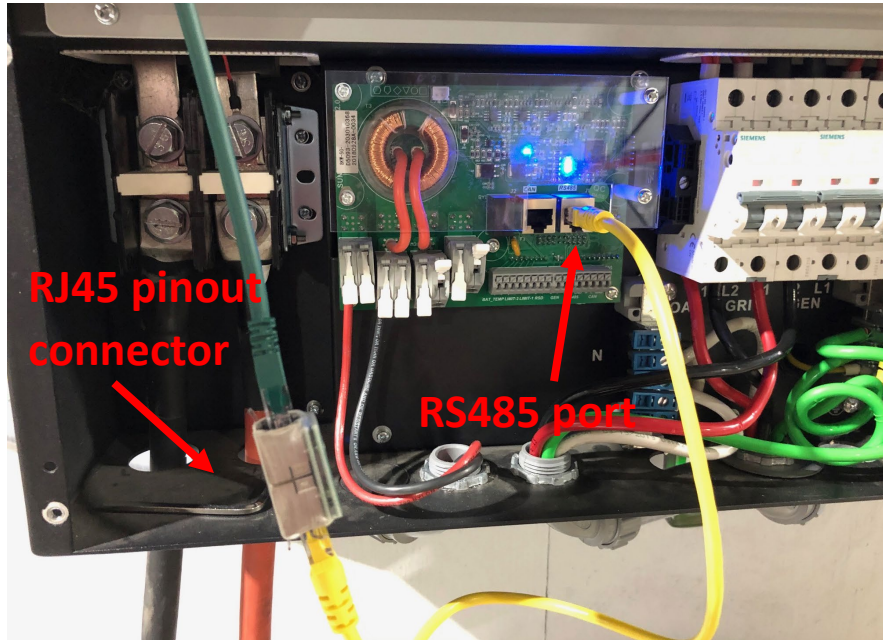
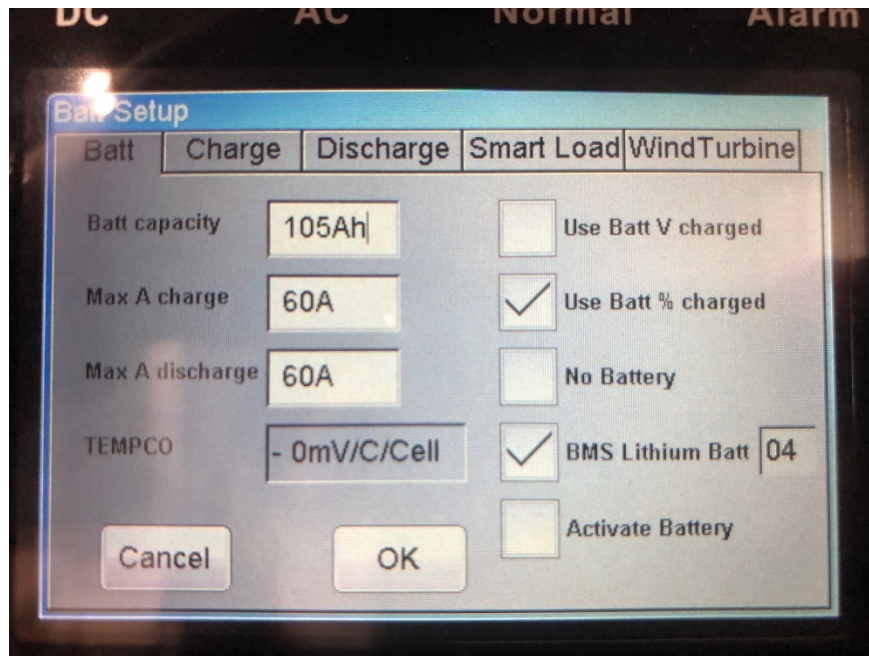
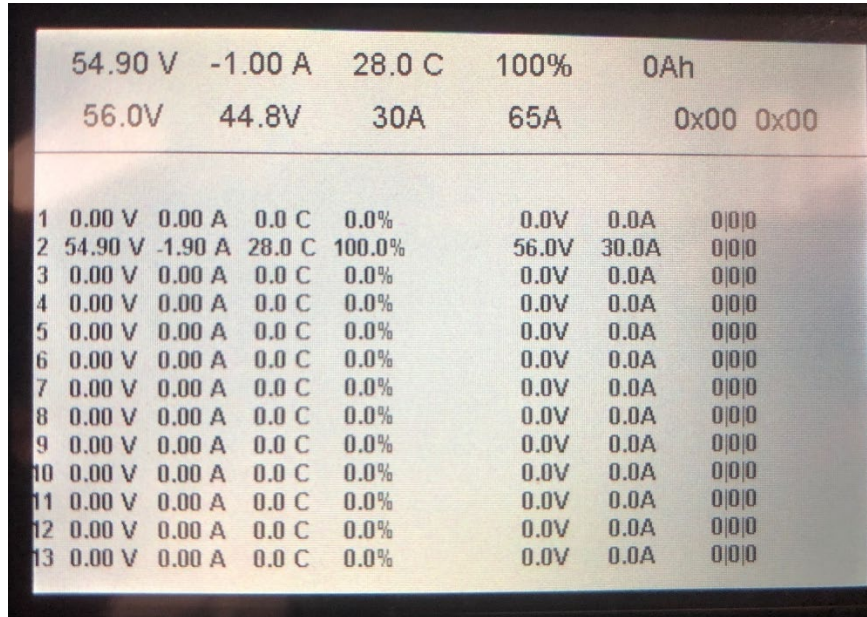

Exhibit D



How To Set Up Fortress Power Lithium Batteries Using Sol-Ark Inverter

Exhibit E



54.90 V		-1.00 A		28.0 C		100%		0Ah	
56.0V		44.8V		30A		65A		0x00 0x00	
1	0.00 V	0.00 A	0.0 C	0.0%	0.0V	0.0A	0 0 0		
2	54.90 V	-1.90 A	28.0 C	100.0%	56.0V	30.0A	0 0 0		
3	0.00 V	0.00 A	0.0 C	0.0%	0.0V	0.0A	0 0 0		
4	0.00 V	0.00 A	0.0 C	0.0%	0.0V	0.0A	0 0 0		
5	0.00 V	0.00 A	0.0 C	0.0%	0.0V	0.0A	0 0 0		
6	0.00 V	0.00 A	0.0 C	0.0%	0.0V	0.0A	0 0 0		
7	0.00 V	0.00 A	0.0 C	0.0%	0.0V	0.0A	0 0 0		
8	0.00 V	0.00 A	0.0 C	0.0%	0.0V	0.0A	0 0 0		
9	0.00 V	0.00 A	0.0 C	0.0%	0.0V	0.0A	0 0 0		
10	0.00 V	0.00 A	0.0 C	0.0%	0.0V	0.0A	0 0 0		
11	0.00 V	0.00 A	0.0 C	0.0%	0.0V	0.0A	0 0 0		
12	0.00 V	0.00 A	0.0 C	0.0%	0.0V	0.0A	0 0 0		
13	0.00 V	0.00 A	0.0 C	0.0%	0.0V	0.0A	0 0 0		