



### LITHIUM ION PHOSPHATE BATTERY

The Fortress Power eFlex is a 5.4 kWh scalable energy storage solution based on safe and energy dense prismatic Lithium Iron Phosphate cells. The digital processor Battery Management System (BMS) includes high amperage contactor disconnects and advanced Closed-Loop inverter communication, as well as individual cell voltage monitoring, temperature monitoring, and cell balancing to maximize reliability and longevity. Canbus, modbus, and wifi communication enable internet-of-things compatibility. The IP65 case ensures direct water spray and dust will not penetrate the battery internals from all directions. The unit can be wall mounted, floor mounted, and server rack mounted for hard-to-reach access in renewable, marine, RV, mobile, telecom, railway applications and more!

- 98% Roundtrip efficiency
- High Durability and Long-Lasting
- Safe Lithium Iron Phosphate Technology (LiFePO4)
- Flexible mounting options

- Data communication with popular hybrid inverters
- Remote monitoring
- Advanced cell level monitoring and balancing
- Integrated heat sink for 5x better thermal performance

Electrical Specifications	
Nominal Voltage:	51.2V
Nominal Capacity:	105AH
Rated Capacity @ 0.5C (50A):	5,374 kWh
Resistance:	<10 mΩ
Efficiency (at 0.5C):	98%
Self-Discharge:	<1 % / Month
Maximum Allowed Modules in Parallel:	15

Charge Specifications	
Recommended Charge Current:	<55A
Maximum Charge Current:	100A
Recommended Charge Voltage:	54.4V
BMS Charge Voltage Disconnect:	>56V

Discharge Specifications	
Recommended Continuous Discharge Rate:	60A (3KW DC)
Peak Continuous Discharge Rate:	100A (5 KW 60 Min)
Maximum Surge Power Rate:	130A (6.6 KW 5S)
Recommended Low Voltage Disconnect:	48V
Battery Low Voltage Protection:	<45V
Battery recovery Voltage:	45V

Temperature Specifications	
Discharge Temperature:	-4°F~131°F (-20°C ~ 55°C)
Charge Temperature:	32°F ~ 114°F (0°C ~ 45°C)
Storage Temperature:	20°F ~ 95°F (-6°C ~ 35°C)

Mechanical Specifications	
Dimensions: (L*W*H)	21.5 x 23 x 17.5 x 7.3 inches 546 x 446 x 183 mm
Weight:	108 lbs (49kg)
Terminal Type:	M8
Ring Terminal Size:	3/8ths or larger
Terminal Torque:	7.0 – 7.7 Nm (5.1 – 5.7 ft-lb)
Case Material:	Anodized Aluminum
Enclosure Protection:	IP65
Cell Type Chemistry:	Prismatic - LiFePO <sub>4</sub>

Compliance Specifications:	
Certifications:	UL1973, UL1642
Shipping Classification:	UN 38.3 CLASS 9 (Lithium Ion Battery)

Basic Charging Profile	
Bulk + Absorb Charge	54.4V
Absorb Time	60 minutes
Float Charge	54V
Inverter Charging	2 Stage / No Float
Equalization	No equalization (typical) 54.6V for 10 seconds (rare)
Temperature Compensation	None



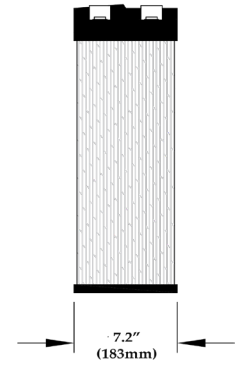
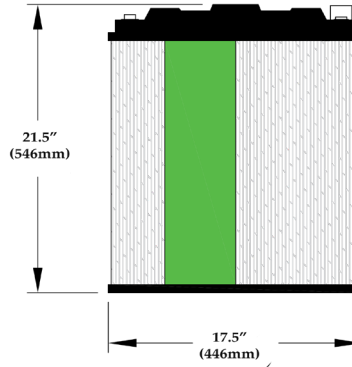
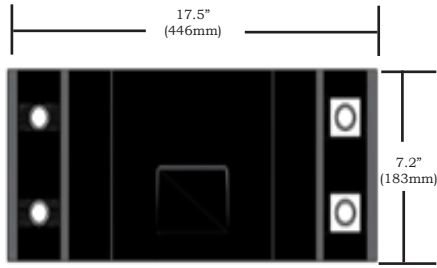

Accessories (Not Included)

Wall Mount Kit

Wall Mount Bracket

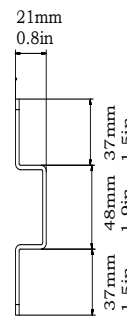
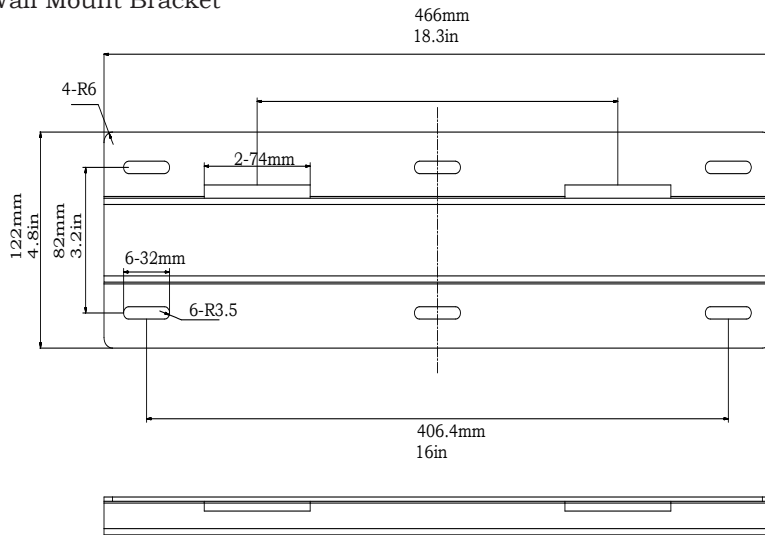

Wall Mount Hook

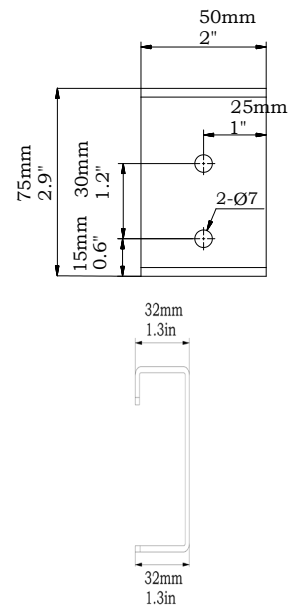

Server Rack Mount Kit

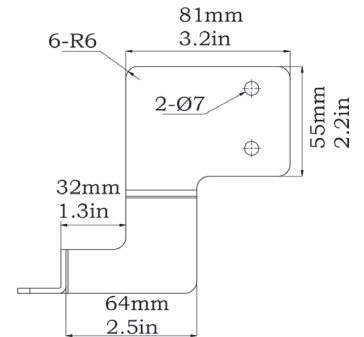
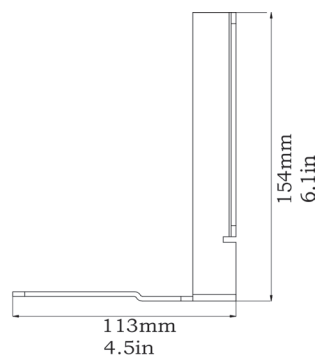
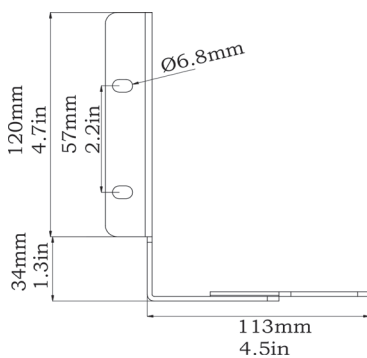

Scan for  
Installation  
Manual:

