



FORTRESS EFLEX 5.4 kWh LITHIUM BATTERY INSTALLATION MANUAL

SECURE YOUR ENERGY WITH FORTRESS LITHIUM BATTERY SYSTEMS

Fortress batteries utilize the industry's most environmentally benign chemistry- Lithium Ferro Phosphate (LFP), which eliminates operating temperature constraints, toxic coolants, and the risk of thermal runaway and fire. The built-in smart Battery Management System (BMS) integrates multilevel safety concepts: Overcharge and Deep Discharge Protection; Voltage and Temperature Observation; Cell balancing.

Fortress high-performance Lithium Batteries are manufactured at the highest quality standards. It comes with large power capacity and a fast charging and continuous discharge power. LFP Chemistry also has nearly twice the cycle life of other Lithium technologies such as NMC. The proprietary architecture and BMS eliminate the need for cooling or ventilation, which creates a 98% efficient round-trip conversion of energy.

The Fortress eFlex is safe, easy to install, consistently reliable, and highly efficient. It provides you with the lowest lifetime energy storage cost.

This installation manual contains information concerning important procedures and features of Fortress Power lithium batteries. Read all the instructions in this manual before installation, operation, transportation, storage, and maintenance.



General Information



CAUTION! Do not combine Fortress Lithium Batteries with other brands or chemistries; Do not mix Fortress Lithium Batteries from different installations, clients, or job sites.



CAUTION! Do not disassemble or modify the battery. If the battery housing is damaged, do not touch exposed contents.



Ambient temperature impacts battery performances, please follow instructions to set up system parameters.



Fortress Lithium Batteries are designed for parallel operation only - do not arrange in series for increased voltage. Series arrangement can result in damage to Fortress Lithium Batteries and will void warranty!



Do not combine Fortress Power Battery with other brands or chemistries. Do not mix different capacity batteries, do not mix batteries from different installations or job sites.



CAUTION! Verify polarity at all connections with a standard voltmeter before energizing the system. Reverse polarity at the battery terminals will void the Warranty and destroy the batteries. Do not short circuit the batteries.



Retrofitting Fortress Lithium batteries to an existing system is not recommended. Like all other batteries, Fortress Lithium Battery's open voltage will diminish during the operation. Parallel batteries with different open voltage may cause reverse currents, which could damage the batteries.



CAUTION! Connect communication cable before turning on eFlex.



NOTE! Without exception, products experiencing terminal burn out will not covered under the warranty.

Table of Contents

General Information 2

Specifications 5

Features 6

Registering for the Fortress Power Warranty 7

1. SAFETY 7

 1.1 General safety precautions 7

2. IMPORTANT NOTES 8

 2.1 Transportation and Handling 8

 2.2 Storage 9

 2.3 Response to emergency situations 9

 2.4 Charge/Discharge 10

 2.5 Charging notes 10

 2.6 System sizing 10

3. PRODUCT INTRODUCTION 11

 3.1 Unboxing Check list 11

 3.2 Accessories and Part Numbers 12

4. INSTALLATION 12

 4.1 Tools & Materials 12

 4.2 Inspection before Installation 13

 4.3 Installation Considerations 13

 4.4 Installation Steps 14

 4.4.1 Mounting the battery pack to a wall 14

 4.4.2 Floor mount installation 15

 4.4.3 Other installation methods 16

 4.4.4 Connecting the battery to the Charge Controller and/or Hybrid Inverter 16

 4.4.5 Using RS485 and CAN Communication 16

 4.4.6 Commissioning a single eFlex battery pack 17

 4.4.7 Commissioning multiple eFlex batteries in parallel 17

 4.6 System Commissioning 19

5. OPERATION 20

5.1 Charging 20
 5.1.1 Use the following steps to charge the battery with an external charger: 20
5.2 Discharging 20
5.3 Parameter set up guide for Charger/Inverter 20
6. INTERFACE GUIDE 22

Specifications

Electrical Specifications	
Nominal Voltage:	51.2V
Nominal Capacity:	105AH
Rated Capacity @ 0.5C (50A):	5.374 kWh
Resistance:	<10 mΩ
Efficiency (at 0.5C):	98%
Self-Discharge:	<1%/Month
Maximum Allowed Modules in Parallel	15

Charge Specifications	
Recommended Charge Current:	<55A
Maximum Charge Current:	100A
Recommended Charge Voltage:	54.4V
BMS Charge Voltage Disconnect:	>56V

Discharge Specifications	
Recommended Continuous Discharge Rate:	60A (3KW DC)
Peak Continuous Discharge Rate:	100A (5KW 60 Min)
Maximum Surge Power Rate:	130A (6.6 KW 5S)
Recommended Low Voltage Disconnect:	48V
Battery Low Voltage Protection:	<45V
Battery recovery Voltage:	45V

Temperature Specifications	
Discharge Temperature:	-4°F ~ 131°F (-20°C ~ 55°C)
Charge Temperature:	32°F ~ 114°F (0°C ~ 45°C)
Storage Temperature:	20°F ~ 95°F (-6°C ~ 35°C)

Mechanical Specifications	
Dimensions:	18x23x7.3 inches 446x546x183 mm
Weight:	108lbs (49kg)
Terminal Type:	M8
Ring Terminal Size:	3/8ths or larger
Terminal Torque	7.0 – 7.7 Nm (5.1 – 5.7 ft-lb)
Case Material:	Anodized Aluminum
Enclosure Protection:	IP65
Cell-Type Chemistry:	Prismatic – LiFeP04

Compliance Specifications:	
Certifications:	UL1973, UL1642
Shipping Classification:	UN 38.3 CLASS 9 (Lithium Ion Battery)

Basic Charging Profile	
Bulk + Absorb Charge	54.4V
Absorb Time	60 minutes
Float Charge	54V
Inverter Charging	2 Stage / No Float
Equalization	No equalization (typical)
Temperature Compensation	None

Features

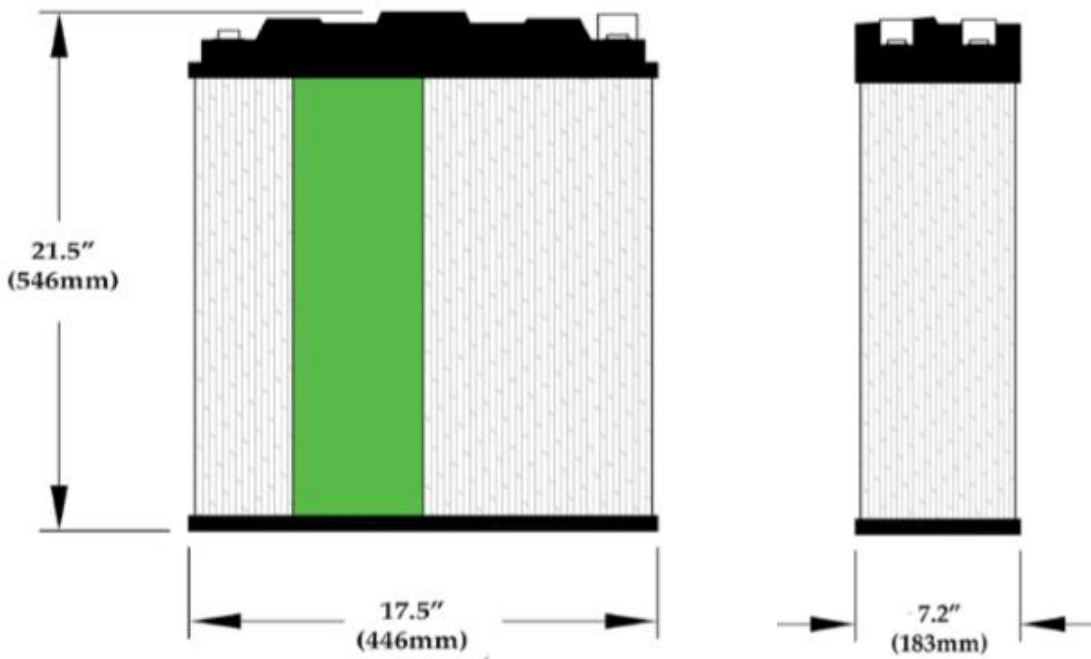

Registering for the Fortress Power Warranty

Fortress Power batteries come with a warranty that depends on charge parameters that define the depth of discharge (DoD) and other important variables. To ensure Fortress Power is able to honor the warranty, please fill out the warranty letter at <https://www.fortresspower.com/product-warranty/> as soon as the system is commissioned. The charge parameters depend on your brand of inverter. Please find the integration guides for many common inverters within the Download Center on our web page. If you need further help, please contact techsupport@fortresspower.com

1. SAFETY

1.1 General safety precautions

- ❖ During installation of the battery, the utility grid and solar input must be disconnected from the battery pack wiring. Wiring must be carried out by qualified personnel. The battery pack is not user serviceable. High voltage or current is present in the device. The electronics inside the battery pack are vulnerable to electrostatic discharge.
- ❖ All types of breakdown of the product may lead to a leakage of electrolyte or flammable gas. Observe the following precautions:
 - ❖ Risks of explosion
 - Do not subject the battery pack to strong impacts.
 - Do not crush or puncture the battery pack.
 - Do not dispose of the battery pack in a fire.
 - ❖ Risks of fire
 - Do not expose the battery pack to temperatures in excess of 122 °F.
 - Do not place the battery pack near a heat source such as a fireplace.
 - Do not expose the battery pack to direct sunlight.
 - Do not allow the battery connectors to touch conductive objects such as wires.
 - ❖ Risks of electric shock
 - Do not disassemble the battery pack
 - Do not touch the battery pack with wet hands
 - Do not expose the battery pack to moisture or liquids
 - Keep the battery pack away from children and animals.
 - Do not wear watches, bracelets, bracelets, rings and other conductive objects during operation
 - ❖ Risks of damage to the battery pack
 - Do not allow the battery pack to come into contact with liquids.
 - Do not subject the battery pack to high pressures.
 - Do not place any objects on top of the battery pack.



IMPORTANT NOTE: Circuit Breakers, Disconnects and Fuses should be employed throughout several points of a power storage and generation installation to effectively isolate and protect all components of the system to safeguard against faults, short circuits, polarity reversals or a failure of any component in the overall system. Fuses, breakers, wiring ratings and values should be determined by established standards and evaluated by certified electricians, licensed installers, and regional code authorities. The Fortress Lithium Batteries must always be installed with a charge controller and the appropriate settings to protect the batteries from open PV voltage and other high voltage charging sources. The Fortress Battery Management System (BMS) alone will not protect the batteries from these extreme electrical phenomena. Failure to adhere to installation protocol will void the Warranty.



CAUTION! Verify polarity at all connections with a standard voltmeter before energizing the system. Reverse polarity at the battery terminals will void the Warranty and destroy the batteries. Do not short circuit the batteries.

Most batteries pose some risk of shock or sparking during the installation and initial wiring and connection process. Wearing insulated gloves, clothing and footwear and using electrically insulated tools are required when working with Fortress Power Lithium Batteries. Cover, restrain or remove jewelry or conductive objects (metal bracelets, rings, belt buckles, metal snaps, zippers, etc.) when working with any electrical or mechanical device. Cover or restrain long hair and loose clothing when working with any electrical or mechanical device.

2. IMPORTANT NOTES

2.1 Transportation and Handling

Do not knock, drop, puncture, or crush the battery; Do not expose battery to flames, incinerate or direct sunlight; Do not open battery case or disassemble the battery; Do not lift battery by the terminal cables; Do not vibrate battery; Do not expose battery to water or other fluids; Do not expose battery to open flame; Do not place the product nearby highly flammable materials, it may lead to fire or explosion in case of accident; Store at cool and dry place. Do not store in greenhouses and storage areas for hay, straw, chaff, animal feed, fertilizers, vegetables or fruit products; Store the product on a flat surface; A ventilated area is strongly recommended for handling the product; Store the product out of reach of children and animals; Store the product where it should be minimal dust and dirt in the area; do not transport battery upside down. Do not disassemble the battery or change the structure of the battery by yourself.

2.2 Storage

Do not expose battery to high temperatures. Fortress Lithium Batteries should be stored out of direct sunlight under the following temperature conditions. The battery circuit/BMS should be off.

Relative Humidity (Min./Max.): 5%~75% RH

Storage Temperature (Min./Max.):

Minimum storage temperature		Maximum storage temperature		Storage Duration	Minimum State of Charge
-20°C	-4°F	95°F	35°C	3 Months	50%
-10°C	14°F	95°F	35°C	6 Months	40%
0 - 15°C	32°F – 59°F	95°F	35°C	12 Months	20%

Systems should be put into storage at 60% SOC and checked monthly to ensure the system SOC does not fall below 20%. At 20% SOC the battery will self-discharge in approximately 2 months. Also check the voltage every 3 months and recycle every 6 months if the battery is not use for long time.

2.3 Response to emergency situations

The battery pack comprises multiple batteries that are designed to prevent hazards resulting from failures. However, Fortress Power cannot guarantee their absolute safety.

❖ Leaking Batteries

❖ If the battery pack leaks electrolyte, avoid contact with the leaking liquid or gas. If one is exposed to the leaked substance, immediately perform the actions described below.

- **Inhalation:** Evacuate the contaminated area and seek medical attention.
- **Contact with eyes:** Rinse eyes with flowing water for 15 minutes and seek medical attention.
- **Contact with skin:** Wash the affected area thoroughly with soap and water, and seek medical attention
- **Ingestion:** Induce vomiting, and seek medical attention

❖ Fire

- In case of fires, make sure that the extinguisher is available near the battery pack. If possible, move the battery pack to a safe area before it catches fire.

Note: FM-200 fire extinguishers, sands, carbon dioxide, dry chemical powder and foam are the most effective means to extinguish a Lithium Ferrous Phosphate (LFP) battery fire

- Use ABC Fire extinguisher, if the fire is not from battery and not spread to it yet.

2.4 Charge/Discharge

- ❖ Do not use unqualified equipment for charging and discharging, please follow the correct instructions for use
 - Do not discharge the battery when the battery is depleted
 - Do not charge or discharge batteries that are hot, deformed, or leaking.
- ❖ The output cable length of the battery should be less than 10 meters long
- ❖ Do not connect a power and load that exceed the power level to the two ends of the battery
- ❖ Do not mix different batteries
 - Different manufacturers, chemistries, models, and lifespans cannot be paralleled

2.5 Charging notes

The battery must be transported, stored, and used in accordance with the instructions in this manual. If any of the following improper operations occur, this product will cancel the free warranty.

If the following scenarios occur, the battery must be charged before use, otherwise the battery damage caused is not covered by the free warranty:

- ❖ The battery has undergone long-term transportation or storage and has not been operated in accordance with the supplementary power requirements.
- ❖ The battery is in a disabled or standby state for a long period of time during transportation or storage.
- ❖ The battery was vented during use and reached under-voltage protection status. For more than 30 days, the battery was not operated in accordance with the requirements of battery recharge.

2.6 System sizing

Please refer to our sizing guide and warranty letter for appropriate sizes between various inverter models and the eFlex. Using an inverter with a charging rate greater than the maximum charge rate of the batteries (total) will trigger battery safety mechanisms.

Further precautions should be taken when adding charge controllers via DC coupling to ensure the inverter and charge controllers do not charge the battery concurrently, when and if their combined charge current totals are greater than the charge current of the combined battery bank. Take additional extra precautions when using wind power to charge the battery, or if the inverter and charge controllers are not the same manufacturer.

Please contact Fortress Power tech support for help sizing the system.

3. PRODUCT INTRODUCTION

3.1 Unboxing Check list

Please confirm and do not discard the following items:

CAN Bus Terminator + Cap. Installed on the last available communication port of the eFlex when paralleling multiple batteries. The terminator is installed backwards into the cap.

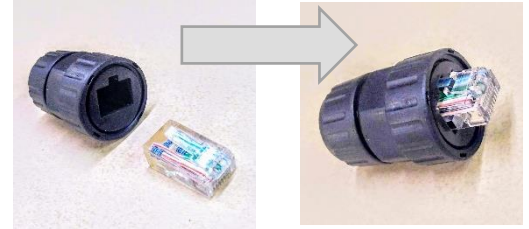

RJ45 adaptor. Installed between the eFlex communication port and the battery inverter during closed loop communication on compatible inverter systems. Alternately, this can be used along with a RS485 cable as a CAN bus terminator if the Can Bus terminator + cap are lost.

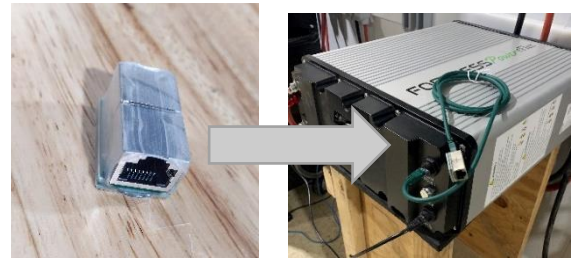

RS485 cable + RJ45 Cable + Cable glands. The included RS485 cables are waterproof and moisture proof. Please match environmental ratings of additional RS485 cables if appropriate.



Battery Terminal Caps. Place these caps over battery terminals to protect against accidental contact.

Mounting Brackets

Floor Mount Bracket x 2 – The floor mounts secure the eFlex to a wall or structure to prevent accidental tipping over of the batteries. Other kinds of mounting brackets are available for purchase.



3.2 Accessories and Part Numbers

These mounting accessories are available for purchase. Please contact sales@fortresspower.com.

Fortress Kit Name	Description	Kit Quantity
eFlex - wall mount kit	Wall mount panel	2
	Wall mount hooks	4
	Hammer screw M6	4
	Hammer nut M6 8mm	4
eFlex- shelf mount kit	Rack mount kit left	1
	Hammer screw M6	4
	Hammer nut M6 8mm	4
	Rack mount kit right	1
eFlex - floor mount kit	Connection Plate	1
	Hammer nut M6 8mm	1
	Hammer screw M6	1

4. INSTALLATION

Safe and reliable installation requires trained and certified technicians. The following discussion of Fortress Power Battery configurations is a basic primer. Follow all requirements for Energy Storage Systems in the National Electric Code. Due to the variety of systems and components in the field, all possible scenarios are not covered. This is not the purpose of this section of the manual. Refer to professional installers regarding your system and its components and specifications. We encourage you or your installer to contact us with any specific questions for technical support. We are committed to working with you and your installation team to achieve a safe, reliable storage system that will provide years of maintenance free service.

4.1 Tools & Materials

- ❖ The following insulated tools and materials are required:
 - Positive and negative battery cables. Please refer to the published Battery Cable Sizing Chart for the proper size, based on your system specification.
 - Positive and Negative Terminal lug recommendation: M8 (diameter: 8mm or 5/16in). Note that ring terminal size for the terminal lug is 3/8ths or larger.
 - Screwdriver
 - Communication Bus Terminator: to Match Impedances during parallel setup
 - RS 485 cable
 - OSHA approved personal protective equipment

		
Insulated gloves	Safety Glasses	Safety Shoes

4.2 Inspection before Installation

- ✓ Check the battery package, type, quantity, appearance and other components
- ✓ Check if there is any damage on the battery box
- ✓ Check the battery terminals and connections to make sure they are clean, free of dirt, fluids and corrosion
- ✓ Check the Open Circuit Voltage.
 - Set the battery on a clean working space.
 - Make sure the + and - terminals are not contacting anything.
 - Locate the eFlex Power Button and press it momentarily. Wait for ~10 seconds for the LED self - diagnostic to complete before continuing to the next eFlex.
 - Confirm that the LED lights are green and that the BMS light does not remain on. The operator should see the LED lights indicating the battery state of charge.
 - Using a Voltage Meter check that the voltage across the terminals is between 50V-55V.
 - If Voltage is <50V, charge the battery using an approved battery charger.
 - If the Voltage is >55V, contact Fortress Power.



IMPORTANT NOTE: Please inform us of any problems within 7 days of receipt of goods. Otherwise, we deem that clients have no objection to the goods.

4.3 Installation Considerations

Although the eFlex is IP65 rated, if it is to be installed outdoors it is recommended that the installation location meet the following conditions:

- ✓ At minimum, the eFlex should be protected from inclement weather with a cover/enclosure. The IP65 rating of the eFlex prevents ingress of direct water spray and dust. However, the eFlex cannot be immersed in water, nor are its exposed terminals waterproof.
- ✓ The floor is flat and level (Inclination < 15°).
- ✓ There is minimal dust and dirt in the area.
- ✓ Adequate clearance is provided around battery terminals is maintained for access.
- ✓ The eFlex has an insulated base so may be installed directly on concrete if floor mounting.
- ✓ All battery cables and their connections should be tight, intact, and NOT broken or frayed
- ✓ Check torque on terminal bolts

- ✓ Replace any damaged batteries and cables
- ✓ There are no flammable or explosive materials.
- ✓ The optimal ambient temperature is from 59 °F to 95 °F for longest battery life but more extreme temperatures are allowed for battery operation and storage. The best location will maintain temperature and humidity at a constant level.



IMPORTANT NOTE: If the ambient temperature is outside the operating range, the battery pack may stop operating to protect itself. Frequent exposure to harsh temperatures may deteriorate the performance and life of the battery pack as well as the product warranty.

4.4 Installation Steps

4.4.1 Mounting the battery pack to a wall

The eFlex 5.4 can be easily wall-mounted using our custom T-slot brackets. The wall-mounting brackets are sold separately. Please ensure the wall and mounting hardware can handle the weight of the batteries.

<https://www.fortresspower.com/fortress-power-video-library-2/>

1. Line up the top bracket on the wall.
 - a. Mark the desired placement using a level to ensure the bracket is horizontal
 - b. Affix the mounting bracket into the wall
2. Using the T-slot screws, fix the male brackets onto the slots in the battery

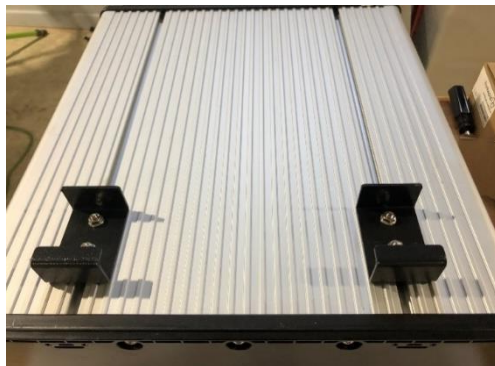

- Once all brackets are properly positioned, carefully lift the battery with the help of someone and gently drop it into the female wall mounted brackets

Note: the eFlex may be wall mounted in any orientation except for sideways with the terminals near the ground (see section 4.4.2 floor mount installation for picture)

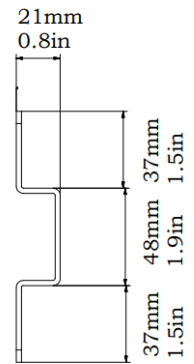
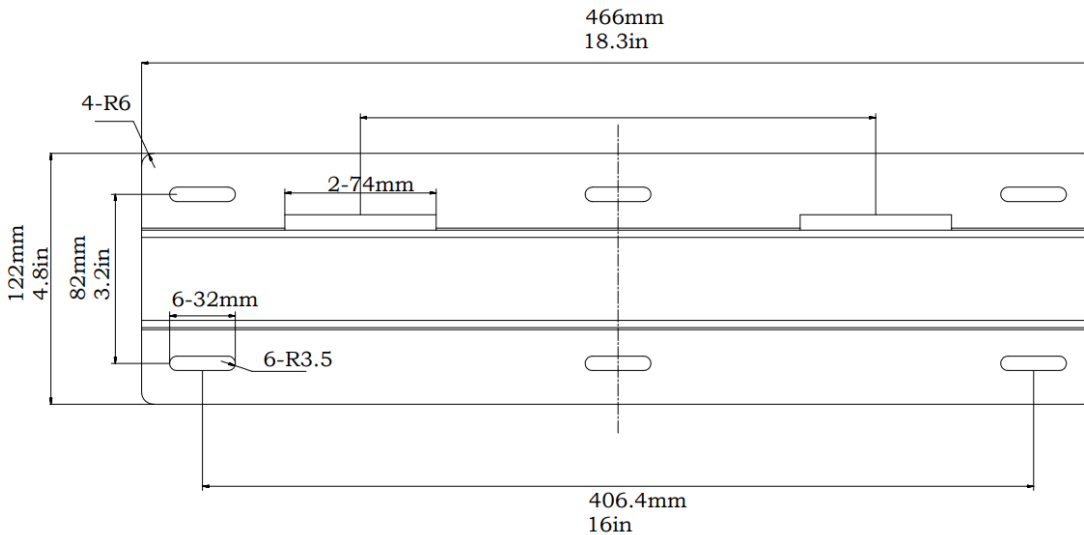

4.4.2 Floor mount installation

The eFlex 5.4 can be floor-mounted in several orientations. **The orientation depicted to the right, with the terminals towards the ground, is the only orientation NOT allowed.** All other orientations are allowed, but regardless of orientation, the included floor mounting bracket must be used to prevent the battery from tipping over. Therefore, it is common to put the back of the eFlex battery against the wall.

- Place the eFlex in the preferred orientation
- Attach the mounting bracket using the T-slot fastener and T-slot groove on the back of the eFlex
- Screw the mounting bracket into the wall
- Connect the battery terminals to the corresponding bus bar and inverter



4.4.3 Other installation methods

The eFlex is designed for multiple installation methods. The T-slot at the back of the enclosure provides the flexibility to use standard size 8 - M6 or M8 hammer screw to secure the battery to a variety of racks, including 19" server racks. In all cases, a clearance of 1" around the eFlex battery is required. Please visit <https://www.fortresspower.com/fortress-power-video-library-2/> for videos on installing the eFlex.

4.4.4 Connecting the battery to the Charge Controller and/or Hybrid Inverter

1. Ensure the battery is turned off by verifying the LED lights are is off and there is no voltage across the terminals.
2. Install the positive cable first and the negative cable second. Do not cross the positive and negative terminals; also, ensure the terminals are not connected to any metal mounting, fixture, or body part. Ensure the terminals are tightened to the recommended terminal torque of 7.0 – 7.7 Nm (5.1 – 5.7 ft-lb)

The Fortress Lithium Batteries are equipped with two M8 threaded terminals with a lock washer and nut. 8mm ring terminals or 3/8ths inch ring terminals, along with proper size wiring cables, are required to connect the battery to the inverter/charger. **Do not reverse polarity-- doing so will void warranty. Use a voltmeter to check polarity before connecting terminals.**

4.4.5 Using RS485 and CAN Communication

Fortress eFlex 5.4 has a self-managed Battery Management System (BMS). No communication is required between a battery-based inverter and the eFlex 5.4 to operate the system. The unit has two ports on the front face of the battery. Both ports are designed to support RS 485 and CAN communication. These ports are used in multi-battery in parallel setup (see section 4.4.7.) or in some cases to communicate with a compatible hybrid inverter/charge controller. Below is a sketch of the communication between paralleled batteries.

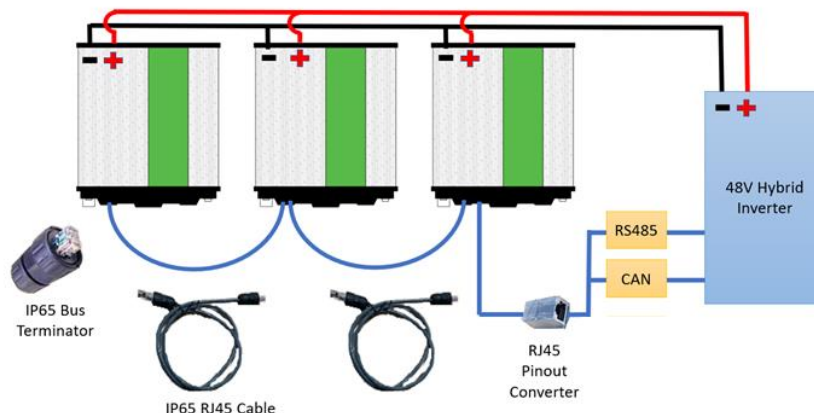

If making a communication cable, please refer to the pinout diagram for an RJ45 cable below.

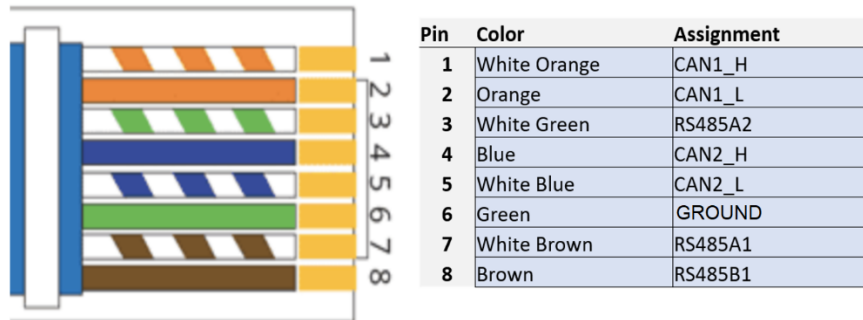

CAUTION! Please check with Fortress Power to see if you can use the CAN comm. port to connect the battery to your charge controller or battery-based inverter.

4.4.6 Commissioning a single eFlex battery pack

Installation procedure for a single eFlex battery

1. **Turn the eFlex on momentarily to check battery voltage.** Check that voltage between terminals is between 50-55V. If the voltage is too low, a slow charging to 50V is needed. Turn off the eFlex.
2. **Put the inverter disconnect into “OFF” position** (if there is any). Make sure the eFlex battery and any charge controllers are off/disconnected as well.
3. **Connect the eFlex DC positive and negative terminals** to the inverter.
4. **Put the inverter breaker into “ON” position.** Note: always turn the eFlex battery on first prior to turning on the inverter. If a shut down is required, always turn the inverter OFF first prior to turning OFF the eFlex battery.
5. **Put any DC charge controllers into the “ON” position.**
6. **Turn on eFlex unit** by pressing the eFlex power button and waiting ~10sec until LED diagnostic is complete. Under normal operation, the eFlex LEDs will show state of charge after the diagnostic is complete. The red BMS light should not be on.

4.4.7 Commissioning multiple eFlex batteries in parallel

For a maximum battery bank size of 81KWH, up to 15 eFlex batteries can be connected in parallel. All wires should be an appropriate gauge and constructed to handle the loads that will be placed upon them. A qualified installer should understand this and must adhere to industry standards and published electrical guidelines.

The storage capacity and total permissible charging and discharging amperage are increased by the parallel arrangement. The overall voltage is not changed. Instead, the available amperage from the

system is increased with each additional parallel battery. For example, in a parallel system with two batteries, the available charging and discharging current is twice that compared to a single battery.

Please follow this procedure to commission eFlex batteries in parallel:

1. **Turn OFF all equipment in the system**
2. **Turn on batteries to check voltages independently.** Make sure the voltage difference between the highest voltage and lowest voltage battery is **less than 0.5V to ensure trouble-free start-up of the whole system.**
3. **Connect the positive and negative common DC bus to the inverter.**
4. **Prepare and connect communication cable.** Each unit comes with one IP65 rated RJ45 cable is used using the RS485 standard. Daisy chain the RS485 cables to each unit utilizing either one of the RJ485 ports.
5. **Plug the can bus terminator into the last RJ485 port at the end of the daisy chained eFlex units.**
 - a. **Open Loop Communication.** If open loop communication is to be used, plug a second can bus terminator into the first RJ485 port on the daisy chained eFlex units.
 - b. **Closed Loop Communication.** If close loop communication is to be used with a compatible inverter, plug a RJ45 cable into the first RJ485 port, and then plug the other end into the RJ45 pinout converter.
6. **Turn on the first eFlex unit and wait 10 seconds for the diagnostic to complete before turning on the next eFlex unit.**
7. **Turn on the inverter system and then the charge controller system.** Note: some inverters have high in-rush current and need to be pre-charged manually, or you can choose to use BMS pre-charge function to start it up. This may require the inverter to be turned on first before you turn on the battery.
8. **For inverter-specific settings,** visit <https://www.fortresspower.com/resources/> for the most recent integration manual for the specific inverter brand.



Canbus Terminator

 **CAUTION!** Installation should be designed to minimize the voltage drop between battery. There are a few best practices: Maintain identical wire length and wire construction from each Fortress Power Battery terminal to the common bus. If you parallel more than 4 units, a battery combiner/bus bar is highly recommended.

 **CAUTION!** For connecting multiple units: Maintain the recommended clearance between units - at least 0.5 inches (12mm).

 **CAUTION!** When paralleling the eFlex 5.4 batteries without connecting them via RJ45 cable(s), please make sure the difference between the highest voltage and lowest voltage does not exceed 0.5 volts. A large current flow from the higher voltage battery to the

lower voltage battery could potentially damage one or both batteries. Resulting damage to the battery will void the warranty.

4.5 KEY POINTS SUMMARY:

1. Each Fortress Lithium Battery contains circuitry that protects the Lithium Ferro Phosphate cells from overcharging, over-discharging, and excessive load amperage. If the values specified are exceeded, the battery will enter a protective shut down state. In some cases, this may result in the need to re-initialize an inverter charger or other pieces of equipment in the installation. In other cases, the inverter's system settings may be saved within the inverter memory storage and will not need to be reset. This is not an absolute standard but is common among most inverter chargers. Check your inverter manufacturer specifications.
2. Although each Fortress Lithium Battery contains circuitry that protects the Lithium Ferro Phosphate cells from overcharging, over-discharging and excessive load amperage, Fortress Lithium Batteries must always be installed with a charge controller and the appropriate settings to protect the batteries from open PV and other high voltage sources. Fortress Lithium Batteries alone will not protect from extreme electrical phenomena.
4. **GRID TIED SYSTEMS:** Once the Fortress Lithium Battery has been installed, turn on the entire system to test. Once testing has been completed, please disconnect the batteries from the load center until your local Utility Inspector is ready to turn on the entire system. The charge controllers and inverter monitoring systems can drain the Fortress Lithium Batteries over an extended period when the entire system is not fully operational due to the electrical draw of the system components.
5. **OFF GRID SYSTEMS:** Do not connect the Fortress Lithium Batteries until the entire system is ready to turn on and is fully operational.
6. See Inverter and Charge Controller Settings on the Fortress Power website for recommended settings at <https://www.fortresspower.com/resources/> .

4.6 System Commissioning

Final installation and operation guidelines will be dictated by your Electrician and Installer based on the specifics of your installation and any code requirements that apply to your region. Fortress Power technicians and sales staff are available to provide any additional information on the Fortress Lithium Batteries as needed. Please be aware of the potential electrical hazards before interacting with any and all electrical or mechanical devices. Please take all necessary safety precautions in your projects and installations.

5. OPERATION

5.1 Charging



CAUTION! Do not attempt to charge the battery below 32 degrees F (0 degrees C). Attempts to charge at subfreezing temperatures can adversely affect State of Health (SOH) and cycle life and will void the warranty; never charge battery if it is frozen; never charge a visibly damaged battery.

5.1.1 Use the following steps to charge the battery with an external charger:

1. Connect the charger leads to the battery.
2. Make sure that the charger leads, both at the charger and the battery side, connections are tight.
3. Turn the charger on.



CAUTION! Recommended charging current is 55A, Max. 100A (Please follow the specification on Fortress Lithium Battery Datasheet.)

5.2 Discharging

- ✓ Do not discharge battery below operating voltage.
- ✓ Do not discharge battery at rates greater than maximum continuous current.
- ✓ Do not operate in conditions that will exceed the internal operating temperatures of the battery.

5.3 Parameter set up guide for Charger/Inverter

Before commissioning the energy storage system, the appropriate controller and inverter settings must be programmed per the manufacturer's recommendations. Consult the manufacturer's manuals and/or access technical support.

Although Fortress Lithium batteries can perform at very high rates and depths of discharge within a very wide temperature range, in order to achieve extended life cycles and to comply with the Warranty, the following guidelines should be followed:

Understanding Charge Stage

1. Bulk Charge: Charge at Constant Current (CC) to Bulk/Absorb Voltage
2. Absorption Charge: Maintain Constant Bulk/Absorb Voltage (CV)
3. Terminate when charge current drops below 0.05C
4. Unlike Lead Acid batteries, Lithium Ferro Phosphate batteries do not require Float Charge

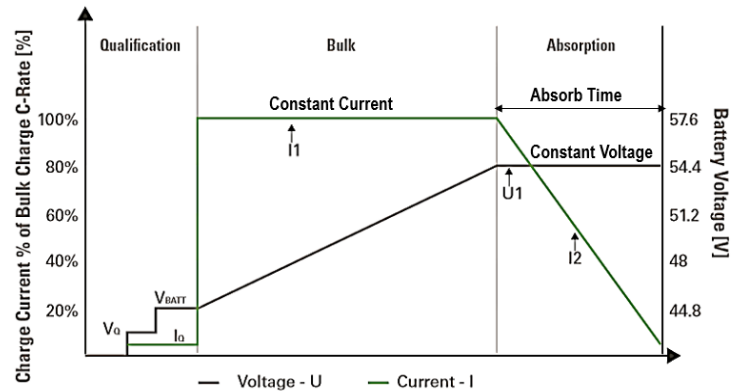

Charger/Inverter configuration recommendation for best Performance:

Note: For inverter-specific integration manuals, visit www.fortresspower.com/Resources

Recommended operating parameters of charger/Inverters For 3,000 Cycles:

- Operating temperature range: 32 F to 120 F (0 °C to 49°C)
- Bulk voltage and absorb voltage should be set to 54.4V

Recommended operating parameters of charger/Inverters For 6,000 Cycles:

- Operating temperature range: 50 F to 110 F (10°C to 43°C)
- Storage must be equal to or more than twice the rated output of the Inverter
- Bulk voltage and absorb voltage should be set to 54.4V

At the End of Cycle Life capacity is Equivalent to 70% Retained Capacity



CAUTION! Do Not Operate Fortress Lithium Batteries at an average temperature exceeding 30 °C / 86 °F over the life of the battery.

6. INTERFACE GUIDE

The eFlex has six LEDs on the front face allowing the user to decode the state of the battery as well as any important messages from the BMS. When the eFlex is turned on, each LED will also turn on and display a LED mode.



The red “BMS” light will turn on during start-up diagnostic as well as when there is a communication error between batteries. If the problem persists, please contact Fortress Power tech support. In normal operation, the “RUN” LED light will be on. The number of charging lights (LED1-4) that are on depends on the battery state of charge. Below is a chart that explains the SOC as a function of the charging LED lights.

Battery status	SOC status	LED1	LED2	LED3	LED4
Full of rest	100%	ON	ON	ON	ON
Charge	0~25%	Flash	OFF	OFF	OFF
	26~50%	ON	Flash	OFF	OFF
	51~75%	ON	ON	Flash	OFF
	76~100%	ON	ON	ON	Flash
Over discharge protection	0%	OFF	OFF	OFF	OFF
Discharge	0~25%	ON	OFF	OFF	OFF
	26~50%	ON	ON	OFF	OFF
	51~75%	ON	ON	ON	OFF
	76~100%	ON	ON	ON	ON

PLEASE CONTACT US FOR TECHNICAL SUPPORT

Fortress Power, LLC
505 Keystone Road,
Southampton, Pennsylvania, 18966
877.497.6937
techsupport@fortresspower.com
www.FortressPower.com

