



FORTRESS
POWER
Secure your energy



FORTRESS POWER





FORTRESS eVault Max 18.5 kWh LITHIUM BATTERY INSTALLATION MANUAL

SECURE YOUR ENERGY WITH FORTRESS LITHIUM BATTERY SYSTEMS

Fortress battery systems utilize the industry's most environmentally benign chemistry- Lithium Ferro Phosphate, which eliminates operating temperature constraints, toxic coolants, and the risk of thermal runaway and fire. The built-in smart Battery Management System (BMS) integrates multilevel safety concepts: Overcharge and Deep Discharge Protection; Voltage and Temperature Observation; Cell balancing.

Fortress high-performance Lithium Batteries are manufactured at the highest quality standard. It comes with large power capacity and a fast charging and continuous discharge power. The proprietary architecture and BMS eliminate the need for cooling or ventilation, which creates an efficient round-trip conversion.

The Fortress Lithium Battery is safe, easy to install, consistently reliable, and highly efficient. It provides you the lowest lifetime energy cost.

This installation manual contains information concerning important procedures and features of Fortress Power Lithium batteries. Read all the instructions in this manual before installation, operation, transportation, storage and

maintenance.

FORTRESS POWER

TABLE OF CONTENTS

1. SAFETY	
1.1 General Safety Precautions and Safety Instructions	6
2. TRANSPORTATION, HANDLING AND STORAGE	
2.1 Transportation and Handling	7
2.2 Storage	7
2.3 Response to Emergency Situations	7
3. PRODUCT INTRODUCTIONS	
3.1 Technical Data	8
4. INSTALLATION	
4.1 Environmental Requirements	9
4.2 Tools and Materials	9
4.3 Inspection Before Installation	9
4.4 Installation Location	10
4.5 Mechanical Installation Steps	10
4.5.1 Mounting and Securing the Battery	
4.5.2 Mounting the Battery Pack to a Wall	10
4.5.3 Connecting the Battery to the Charge Controller and/or Hybrid Inverter	11
4.5.4 Battery Communications	12
4.5.5 Grounding	12
4.5.6 System Commissioning	12
4.6 Parallel Communication Connection	15
4.7 Battery Connections	16
4.8 LCD Display and Alarm Warning	17
4.9 Final Connection of the Installation	18
4.10 Powering off the Unit	18
5. System Expansion	18
6. OPERATING	
6.1 Operating Environment	19
6.2 Charging	19
6.2.1 Charging Stage	19
6.3 Discharging	19
6.4 Parameter Set Up Guide in Charger/Inverter	20
7. DIAGNOSTIC GUIDE	20
8. TROUBLESHOOTING	
8.1 General Symptom-Solution Situations	21

8.2 LCD Display Warnings	22
8.2 Fundamental Troubleshooting Guide	22

1. SAFETY

1.1 GENERAL SAFETY PRECAUTIONS

- All types of damage to the product may lead to a leakage of electrolyte or flammable gas.
- During installation of the battery, the utility grid, solar input must be disconnected from the Battery Pack wiring. Wiring must be carried out by qualified personnel. The battery pack contains no user serviceable parts. High voltage or current is present in the device. The electronics inside the Battery Pack are vulnerable to electrostatic discharge. Observe the following precautions:
- Risks of explosion
 - Do not subject the battery pack to strong impacts.
 - Do not crush or puncture the battery pack.
 - Do not dispose of the battery pack in a fire.
- Risks of fire
 - Do not expose the battery pack to temperatures in excess of 122°F (50°C).
 - Do not place the battery pack near a heat source such as a fireplace.
 - Do not expose the battery pack to direct sunlight.
 - Do not allow the battery connectors to touch conductive objects such as wires.
- Risks of electric shock
 - Do not disassemble the battery pack
 - Do not touch the battery pack with wet hands
 - Do not expose the battery pack to moisture or liquids
 - Keep the battery pack away from children and animals.
- Risks of damage to the battery pack
 - Do not allow the battery pack to come in contact with liquids.
 - Do not subject the battery pack to high pressures.
 - Do not place any objects on top of the battery pack.

IMPORTANT NOTE: Circuit Breakers, Disconnects and Fuses should be employed throughout the energy storage and generation installation to effectively isolate and protect all components of the system against faults, short circuits, polarity reversals or a failure of any component in the overall system.

Fuses, breakers, wiring ratings and values should be determined by established standards and evaluated by certified electricians, licensed installers, and regional code authorities. The eVault Max must always be installed and commissioned with settings to protect the batteries from open PV voltage and other high voltage charging sources. The eVault Max Battery Management System (BMS) alone will not protect the batteries from these extreme electrical events. Failure to adhere to installation protocol will void the Warranty.



CAUTION! Verify polarity at all connections with a digital voltmeter before energizing the system. Reverse polarity at the battery terminals will void the Warranty and destroy the batteries. Do not short circuit the batteries.

Most batteries pose some risk of shock or sparking during the installation and initial wiring and connection process. Wearing insulated gloves, clothing and footwear and using electrically insulated tools are required when working with eVault Max. Cover or remove jewelry or conductive objects (metal bracelets, rings, belt buckles, metal snaps, zippers, etc.) when working with any electrical or mechanical device. Cover or restrain long hair and loose clothing when working with any electrical or mechanical device.



CAUTION! Do not combine the eVault Max with other brands or chemistries; Do not mix eVault Max(s) from different installations, clients, or job sites.



CAUTION! Do not disassemble or modify the battery. If the battery housing is damaged, do not touch exposed contents.

2. TRANSPORTATION, HANDLING AND STORAGE

2.1 TRANSPORTATION AND HANDLING

Do not knock, drop, puncture, or crush the battery; Do not expose battery to flames, incinerate or direct sunlight; Do not open battery case or disassemble the battery; Do not lift battery by the terminal cables; Do not vibrate battery; Do not expose battery to water or other fluids; Do not expose battery to open flame; Do not place the product nearby highly flammable materials, it may lead to fire or explosion in case of accident; Store at cool and dry place. (Do not store in greenhouses and storage areas for hay, straw, chaff, animal feed, fertilizers, vegetables or fruit products; Store the product on a flat surface; A ventilated area is strongly recommended for handling the product; Store the product out of reach of children and animals; Store the product where it should be minimal dust and dirt in the area; do not transport battery upside down.

2.2 STORAGE

Do not expose battery to high temperatures. eVault Max should be stored out of direct sunlight under the following temperature conditions.

Storage Temperature (Min./Max) <1 Months: 14F-110F (-20C ~ 45C)

Storage Temperature (Min./Max.): 41°F/5°C – 95°F/ 35°C

Relative Humidity (Min./Max.): 5%~75% RH

Systems should be put into storage at 60% SOC and checked monthly to ensure the system SOC does not fall below 20%. At 20% SOC the battery will self-discharge in approximately 2 months. Also check the voltage every 3 months and recycle every 6 months if the battery is not use for long time.

2.3 RESPONSE TO EMERGENCY SITUATIONS

The battery pack consists of multiple batteries and a sophisticated Battery Management System that are designed to prevent hazards resulting from failures. However, Fortress Power cannot guarantee their absolute safety.

- Leaking Batteries
- If the battery pack leaks electrolyte, avoid contact with the leaking liquid or gas. If a person is exposed to the leaked substance, immediately perform the actions described below.
 - Inhalation: Evacuate the contaminated area and seek medical attention.
 - Contact with eyes: Rinse eyes with flowing water for 15 minutes and seek medical attention.
 - Contact with skin: Wash the affected area thoroughly with soap and water, and seek medical attention
 - Ingestion: Induce vomiting, and seek medical attention
- Fire
 - In case of fire, make sure that an extinguisher is available near the battery pack. If possible, move the battery pack to a safe area before it catches fire.

Note: Fire extinguisher

- Water, carbon dioxide, dry chemical powder and foam are the most effective means to extinguish a Lithium Ferrous Phosphate (LFP) battery fire
- Use ABC Fire extinguisher, if the fire is not from battery and has not spread to it yet.

3. PRODUCT INTRODUCTION

3.1 TECHNICAL DATA

Electrical

Total Energy (kWh)	18.5
Recommend Charge Current	150
Max. Charge Current (Continuous) [A]	180
Max. Discharge Current Continuous) [A]	180
Max Pulse Current for 10sec [A]	200
Capacity [Ah]	360
Voltage [V]	51.2 (48V Nom)
Charging Temperature [F]	32°F ~ 120°F (0°C ~ 49°C)
Discharging Temperature [F]	14°F ~ 120°F (-10°C ~ 49°C)
Circuit Breaker/Disconnecting Means	250 A
Battery Efficiency	>98%

Mechanical

Dimension [WxDxH in]	20.3 x 20.3 x 42.2
Packaging Dimensions [WxDxH in]	45x24x31
Connection Terminal	M10 or 3/8in
Weight	520lbs (235.87kg)
Enclosure Protection Rating	IP55 (indoor only)
Scalability	Up to 20 units in closed loop communication

4. INSTALLATION

Safe and reliable installation of any electrical power system requires knowledgeable and trained technicians. This manual is intended to be a basic guide covering the specifics of the eVault Max unit itself only, due to the variety of systems and components in the field, all possible scenarios cannot be covered. Refer to your professional installers regarding your system and its components and specifications. We encourage you or your installer to contact us with any specific questions for technical support. We are committed to working with you and your installation team to achieve a safe, reliable storage system that will provide years of maintenance free service.



The eVault Max is designed for parallel operation only - do not arrange in series for increased voltage. Series arrangement can result in damage to eVault Max and will void the warranty!

4.1 ENVIRONMENTAL REQUIREMENTS

Application scenarios	Residential/Small Commercial
Operating Environment	Indoor and away from strong electromagnetic radiation
Operating Temperature	14°F ~ 120°F (-10°C ~ 49°C)
IP grade	IP55
Storage Temperature	Short Duration (≤ 1 month): -20~45°C (-4~110°F) Long Duration (≥ 1 month): 5~35°C (41~95°F)
Operating Humidity	0 ~ 85% non-condensing
Max charge/discharge current vs. Altitude	180A@ $\leq 2,000$ m 162A@2,000m~4,000m
Case Ground requirement	Use at least 6AWG (16mm ²) copper wire

4.2 TOOLS & MATERIALS

The following tools and materials are required:

- Positive and negative battery cables, we recommend copper cable starting at 2/0 AWG for runs of less than 10ft. Please refer to your adopted version of the National Electric Code or Local Authority Having Jurisdiction for more guidance (*not included*)
- Positive & Negative Terminal Lugs: 3/8in (10mm) (*not included*)
- Electrical Conduit: 1in or 2in (*not included*)
- Screwdriver (*not included*)
- Battery parallel communications cable (*included*)
- Inverter to Battery CAT5/5e communications cable (*not included*)
- Wall Mount Stabilizers (*included*)
- OSHA approved personal protective equipment such as the following (*not included*)



Insulated gloves



Safety Glasses



Safety Shoes

4.3 PRE-INSTALLTION CHECKLIST

- Check the battery package, type, quantity, appearance and other components for damage and completeness
- Check the battery terminals and connections to make sure they are clean, free of dirt, fluids or corrosion
- All battery cables and their connections should be tight, intact, and NOT broken or frayed
- Check torque on terminal bolts
- Replace any damaged batteries and cables

IMPORTANT NOTE: Please inform us of any problems with the battery within 7 days of receipt of goods. Otherwise, we will deem the product delivered in good condition.

4.4 INSTALLATION LOCATION

The battery pack must be installed indoors. In addition, make sure that the installation location meets the following conditions:

- The area is completely waterproof.
- The floor is flat and level (Inclination < 15°).
- There are no flammable or explosive materials nearby.
- The optimal ambient temperature is within the range from 59° to 95°.
- The temperature and humidity are maintained at a constant level.
- There is minimal dust and dirt in the area.

IMPORTANT NOTE: If the ambient temperature is outside the operating range, the battery pack may stop operating to protect itself. Frequent exposure to harsh temperatures may deteriorate the performance and life of the battery pack.

4.5 MECHANICAL INSTALLATION STEPS

4.5.1 Mounting and securing the battery

The Fortress eVault Max 18.5 is designed to stand on the floor with the four adjustable legs on the bottom. Four wheels are provided for serviceability only, Installation. We recommend using the wall bracket in high seismic areas. Please refer to the eVault Max Data Sheet for weight and dimensions.

4.5.2 Mounting the battery pack to a wall

1. Fasten the screws through the mounting brackets into the holes of the battery pack on its both sides.
2. Secure the mounting brackets to the wall with screws. Make sure to leave a space of at last 2in inbetween the battery pack and the wall.

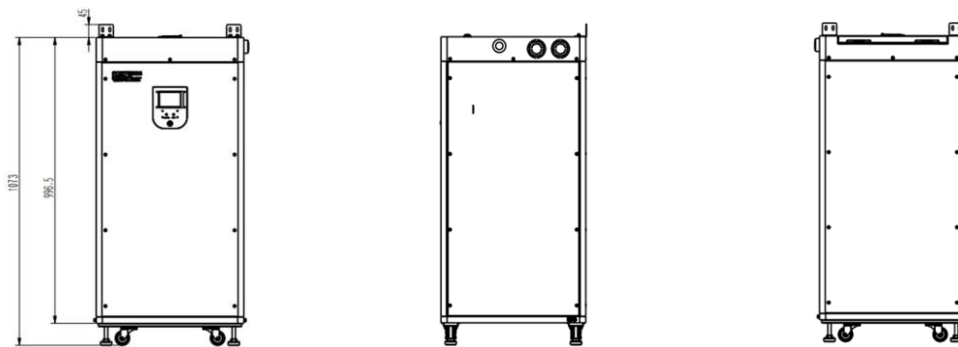

Dimensions are in mm

4.5.3 Connecting the battery to the Charge Controller and/or Hybrid Inverter

The battery terminals are positioned under the top cover. To open the cover, slide the raised latch to the right, the handle will then pop up, rotate it counterclockwise 90° and lift the lid to the open position. Note: the lid does not have a mechanism to keep it from shutting so be sure to open it past 90° or use an object to hold it open.

When connecting the cables ensure that the battery DC breaker is OFF and that the battery screen is off. Pay special attention to the polarity of the connections and do not cross the positive and negative terminals between the inverter/charge controller and the battery; also, ensure the terminals are not connected to any metal mounting point, fixture, or body part.

The eVault Max is equipped with two 3/8s (M10) threaded terminals with a lock washer and nut. Recommended terminal torque is 10.0 –19.1 N·m (7.4 – 14.1 ft.lb) The right-hand terminal is for the positive lead while the left-hand terminal is for the negative. Heavy duty battery ring terminals of size 3/8s (10mm) along with proper size wiring cables are required to connect battery to inverter/charger. Do not reverse polarity, doing so will void warranty. Use a voltmeter to check polarity before connecting terminals.

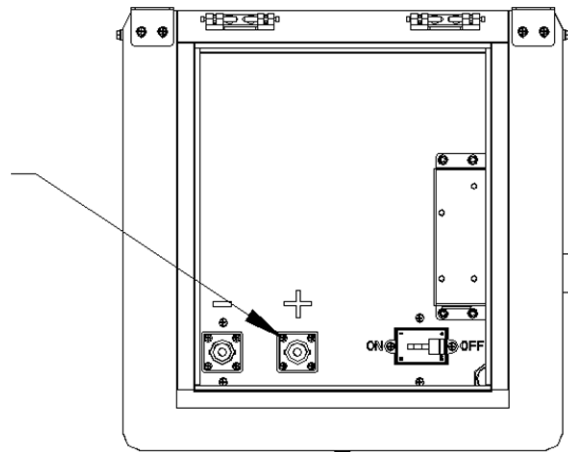

M10 Terminal

Top View

The knockouts are positioned on each side of the battery. The included knockouts are 1in & 2in electrical trade size. There are two on each side of the unit.

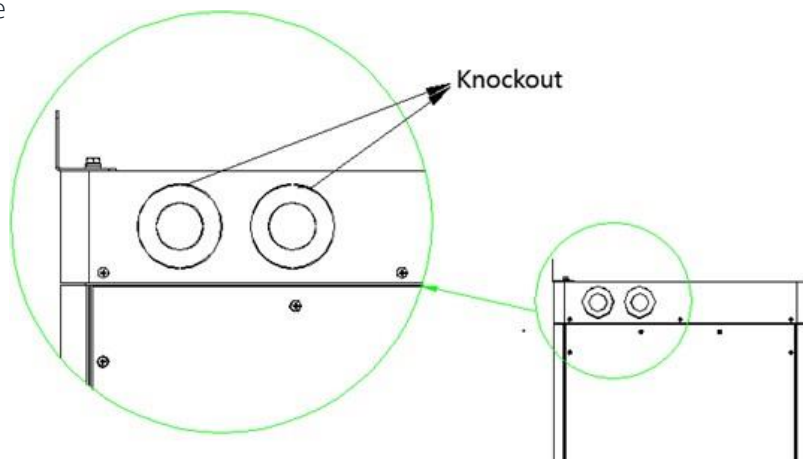

4.5.4 Battery Communications

The eVault Max 18.5 has a self-contained Battery Management System (BMS). No communication is required between a battery-based inverter and the eVault Max 18.5 to operate the system, though closed loop communication is recommended to improve battery and inverter performance.

The Communication Box has five ports next to the battery breaker (refer to communication box picture below). Those ports are designed to support Inverter RS-485 and CAN communication, battery parallel communication (see section 4.4.6.) and USB Logging.

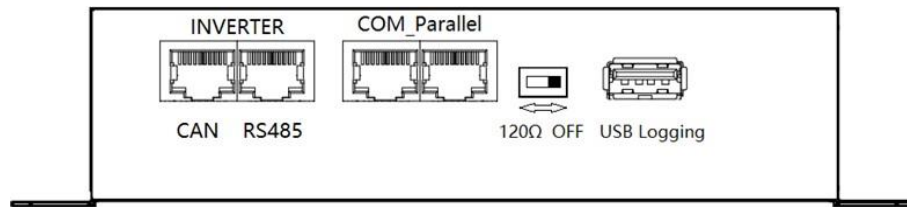

These ports also support MODBUS and CANBUS communication. Please consult with Fortress Technical Support for further assistance.

4.5.5 Grounding

The Fortress eVault Max 18.5 has two grounding lugs on the bottom of battery case.

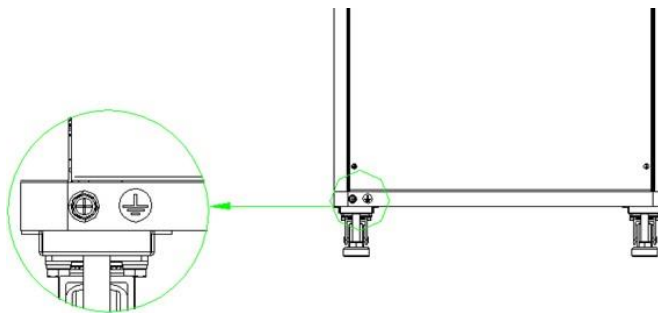

4.5.6 System Commissioning

If you're installing a single eVault Max 18.5, please follow the below steps to start up the system.

1. When using a single battery be sure to set the "Battery ID" to 0 or the unit will not start.
2. Check the DC cables for correct polarity.
3. Switch the battery's 250A breaker to the "ON" position.
4. Switch inverter breaker to the "ON" position.
5. Push the power button on the front of the unit for approximately 8 seconds until the status light and LCD light up.



When installing multiple inverters with one or more eVault Max 18.5, please turn the first inverter on then use the following the steps, then power up the remaining inverters.

4.5.7 Parallel eVault Max Units

eVault Max units with the same capacity may be connected in parallel in configurations of up to 20, this is the maximum number allowed for consistent and robust operation. Quantities greater than this will require consultation with Fortress Power. A qualified installer should understand the complexities of large-scale storage and must adhere to industry electrical design guidelines, including the NFPA standards and local fire codes when installing systems of this size.

The storage capacity and total available current are increased in a parallel arrangement. The following illustration shows how to connect multiple batteries in parallel. Please note that while the overall system voltage is not changed, the available current from the system has been doubled.

1 to 20 eVault Max Parallel Configuration

Closed Loop

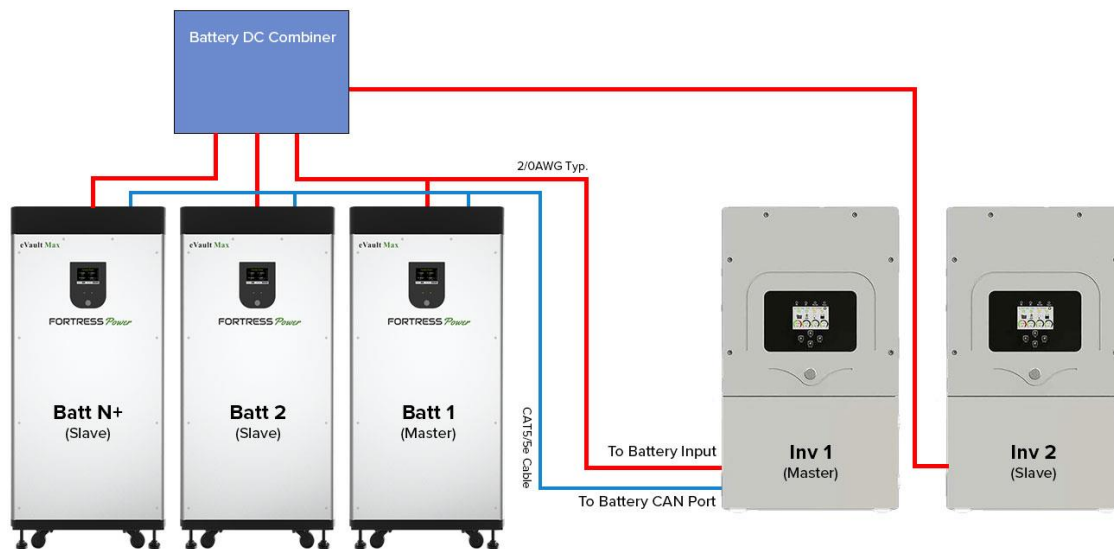

Note: For parallel systems maintain identical wire length and wire type from eVault Max to the system battery combiner. When installing more than one eVault Max, a dedicated battery DC combiner is highly recommended. Please see our [website](#) for application notes on bus bar selection.



CAUTION! The eVault Max is designed for parallel operation only; series arrangement for higher voltage can result in damage to the eVault Max and will void the warranty.

eVault Max Communication Interface Details

Note: The Inverter CAN and RS485 ports are optional and only one is used at a time for closed loop inverter communications. The battery RS484 port is used when the inverter requires a MODBUS interface such as on the Sol-Ark 12, 8, & 5k, as well as the Schneider XW Plus.

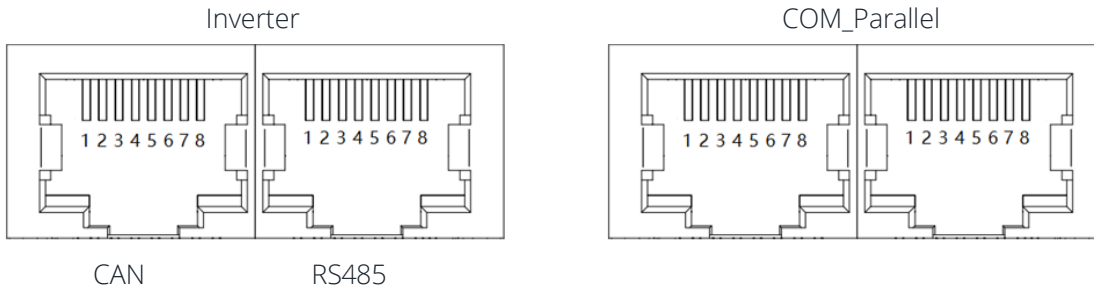

INVERTER CAN PORT

Pin No.	Definition
1.	INVERTER_CANH
2.	INVERTER_CANL
3.	CANGND
4.	NC
5.	NC
6.	NC
7.	NC
8.	NC

INVERTER RS485 PORT

Pin No.	Definition
1.	NC
2.	NC
3.	INVERTER_RS485A
4.	NC
5.	INVERTER_RS485B
6.	RS485GND
7.	NC
8.	NC

BATTERY COM_PARALLEL

Pin No.	Definition
1.	INVERTER_CANH
2.	INVERTER_CANL
3.	CANGND
4.	NC
5.	NC
6.	RS485GND
7.	Parallel_CANL
8.	Parallel_CANH

Procedure to Parallel eVault Max Batteries

4.6 COMMUNICATION CONNECTIONS

1. Confirm that each battery DC circuit breaker is in the "OFF" position.
2. Wire each battery to your systems battery combiner. Connect the applicable AC and DC wiring on the inverter side of the system.
3. Connect the first eVault COM_Parallel **OUT** to the input of the next eVault's **IN** port. Each unit comes with one RJ45 cable for this purpose. If the cable is missing, please make sure the cable you purchase on the market meets the following standards, CAT5/5e or greater, 24AWG pure copper, this is most typical ethernet cables..
4. Per Fig 1. ensure the communication matching resistor of the first and last battery is set as 120Ω, while the others are set to OFF.

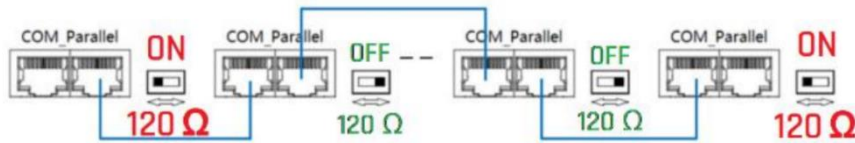

Figure 1

5. Press the button on the front of each battery for approximately 8 seconds one by one, until all batteries start up.
6. Touch the battery LCD to set "Battery ID" from 1 to N (Parallel number) as illustrated in the picture below.



7. Touch the LCD to set Inverter "Protocol ID" to the following:

PROTOCOL ID	SUPPORT INVERTER PROTOCOL
1	Fortress Power/Sol-Ark MODBUS
2	SMA CANBUS
3	Fortress Power CANBUS

4	Victron CANBUS
5	Schneider MODBUS
6	Reserved
7	Reserved
8	Reserved

8. Use a CAT5/5e or greater cable to connect the CAN or RS-485 port of master battery (the Battery ID set as 1) to inverter communication port.
9. Turn ON the inverter breaker, then turn ON all battery DC breakers, and then press the button of master battery (Battery ID 1) for 8+ seconds to turn off. Finally, press the button on the master battery for 3+ seconds to start the automatic PARALLEL PROCESS.
10. The master battery orders the lowest voltage battery of the whole system to pre-charge and turn on relay, and request charge current from inverter. As the battery voltage increases, batteries join the parallel circuit one by one. After all batteries are in parallel, the process ends.

4.7 BATTERY CONNECTIONS

Wire the battery cables and connect them to positive and negative common bus respectively.

For parallel battery connections ensure identical wire lengths and wire type from each eVault Max to the DC combiner.

NOTE: When installing multiple units ensure the recommended spacing distance among units of at least 5inches (12mm).

1. Connect the positive and negative cables from the DC combiner to the inverter.
2. Switch the battery breaker to the "ON" Position
3. Switch the inverter breaker to the "ON" Position



CAUTION! If paralleling the eVault Max 18.5 batteries without connecting them via RJ45 cable(s), please make sure the difference between the highest voltage and lowest voltage does not exceed 0.5 volts. A large current flow from the higher voltage battery to the lower voltage battery and could potentially damage one or both batteries. Resulting damage to the battery will void the warranty.



CAUTION! Verify polarity at all connections with a standard voltmeter before energizing the system. Reverse polarity at the battery terminals will void the Warranty and destroy the batteries. Do not short circuit the battery.

4.8 LCD SCREEN AND ALARM WARNINGS

The LCD display on the front of eVault Max provides Battery Voltage (V), Charging and Discharging Current (A), State of Charge (SOC), as well as Charging and Discharging Power Output (kW). Please note, when the battery is charging, the Current (A) will show a negative value, while during the discharging the Current (A) is positive.



The green light (RUN) indicates system is running properly.

The red alarm light (ALARM) will turn on, if the battery experiences one of those scenarios: High voltage (HV); Low voltage (LV); HT (High Temperature); LT (Low Temperature); Open Circuit (OC) and Short Circuit (SC).

KEY POINTS SUMMARY:

1. Each eVault Max contains a sophisticated Battery Management System that protects the Lithium-Ferro Phosphate cells from overcharging, over-discharging, and excessive load amperage. If the values specified are exceeded, the battery will enter a protective shut down state. In some cases, this may result in the need to re-initialize an inverter charger or other pieces of equipment in the installation. In other cases, the inverter's system settings may be saved within the inverter memory storage and will not need to be reset. This is not an absolute standard but is common among most inverter chargers. Check your inverter manufacturer specifications.
2. If the battery enters a self-protective mode, negligible voltage readings will be present until the unit is reset. In some instances, after a prolonged shut down, a charge might need to be manually applied to the energy storage bank. Should this occur, please contact Fortress Power for technical support.
3. Although each eVault Max contains circuitry that protects the Lithium Ferro Phosphate cells from overcharging, over-discharging and excessive load amperage, the eVault Max must always be installed with a charge controller and the appropriate settings to protect the batteries from open PV and other high voltage sources.
4. GRID TIED SYSTEMS: Once the eVault Max has been installed, turn on the entire system to test. Once testing has been completed, please disconnect the batteries from the load center until your local Utility Inspector grants Permission to Operate the entire system. The charge controllers and inverter monitoring systems can drain the eVault Max over an extended period when the entire system is not fully operational due to the electrical draw of the system components.
5. OFF GRID SYSTEMS: Do not connect the eVault Max until the entire system is ready to turn on and is fully operational.
6. See the [equipment integration guides](#) on our website for details on programming your system. The eVault Max are compatible with most 48V Inverter/Chargers and Charge Controllers. Please contact Fortress Power to learn the recommended settings for any device not explicitly covered in this manual.

4.9 FINAL CONNECTION OF THE INSTALLATION

Final installation and operation guidelines will be dictated by your Electrician and Installer based on the overall properties of and procedures for the equipment in your installation and any code requirements that apply to your region. Fortress Power technicians and sales staff are available to provide any additional information on the eVault Max as needed. Please be aware of the potential electrical hazards before interacting with any and all electrical or mechanical devices. Please take all necessary safety precautions in your projects and installations.

4.10 POWERING OFF THE UNIT

If you need to turn off the unit, hold the button below the screen for 8 seconds.

5. SYSTEM EXPANSION

Adding new eVault Max batteries to an existing system (older than 1yr) is not recommended. Like all other batteries, the eVault Max open circuit voltage and internal resistance can change with age. Parallel batteries with different internal resistance may cause reverse currents, which could damage the batteries

6. OPERATING

6.1 OPERATING ENVIRONMENT

See "3.1 Technical Data" Table

6.2 CHARGING

Never attempt to charge a battery without first reviewing and understanding the instructions for the charger being used. Only use a Fortress Power Approved Lithium Ferro Phosphate (LFP) charger if ancillary charging is required before installation, testing or troubleshooting. Failure to use a Fortress Power approved LFP charger will damage the battery and void the warranty.



CAUTION! Do not attempt to charge the battery below 32°F (0°C). Attempts to charge at subfreezing temperatures can adversely affect State of Health (SOC) and cycle life and will void the warranty; never charge battery if it is frozen; never charge a visibly damaged battery.

6.2.1 Charging Stage - Please follow the following steps to use the charger to charge the battery:

1. Connect the charger leads to the battery.
2. Make sure that the charger lead, both at the charger and the battery side, connections are tight.
3. Turn the charger on.

NOTE: Recommended charging current is 150A, Max. 180A

6.3 DISCHARGING

- Do not discharge battery below operating voltage.
- Do not discharge battery at rates greater than maximum continuous current.
- Do not operate in conditions that will exceed the internal operating temperatures of the battery.

6.4 PROGRAMMING THE INVERTER/CHARGER

Before commissioning the energy storage system, the appropriate controller and inverter settings must be programmed per the manufacturer's recommendations. Consult the manufacturer's manuals and/or access technical support (Schneider, Sol-Ark, SMA, Magnum, Darfon, Outback).

Although the eVault Max can perform at very high rates and depths of discharge within a very wide temperature range, in order to achieve extended life cycles and to comply with the Warranty, the following guidelines should be followed:

Understand Charge Stage

1. Bulk Charge: Charge at Constant Current (CC) to Bulk/Absorb Voltage
2. Absorption Charge: Maintain Constant Bulk/Absorb Voltage (CV)
3. Terminate when charge current drops below 0.05C
4. Unlike Lead Acid batteries, Lithium Ferro Phosphate batteries do not require Float Charge

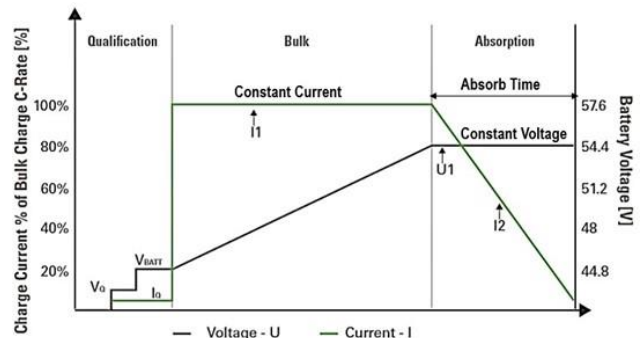

INVERTER/CHARGER CONFIGURATION:

A PDF manual with settings for SMA, Sol-Ark, Schneider, Outback and other Inverters/Chargers is available for download at our [website](#).

For a detailed breakdown of operating conditions and how they can affect battery life and the 10 (5) year battery warranty please see the eVault Max Warranty document on our website.



CAUTION! Do Not Operate the eVault Max at an average temperature exceeding 30°C / 86°F over the life of the battery.

7. DIAGNOSTIC GUIDE

The eVault Max BMS provides multiple levels protection function:

- Over Charge Voltage Protection
- Over Discharge Protection
- Over Current Protection for Discharge Via Thermal Control
- Short Circuit Protection
- ON/OFF Switch
- In the event of a fault the battery protection circuit will open its internal relays disconnecting the negative battery terminals from the internal cells. The battery uses relays and precautions should be taken to reduce voltage spikes and large inductance in the application.

Over Voltage Fault	58.4±0.4V
Over Voltage Recovery	54.0±0.4V
Low Voltage Fault	43.2±0.4V
Low Voltage Recovery	43.2±0.4V

When an Incident occurs or an alarm light is on, please follow this guide as the initial step in the troubleshooting process.

1. Please isolate the battery:
 - a. Turn OFF main DC breaker on top of the battery
 - b. Remove all external power sources to/from battery
2. Make sure Battery Voltage is consistent with LCD Display:
 - a. Turn ON main DC breaker on top of the battery
 - b. Use an available Multimeter to measure the voltage at top of the terminals
 - i. If consistent with LCD Display, please measure the voltage of each battery cell
 - Please see Restart BMS by pushing the POWER Button for at least 10s
 - If Alarm Light persists, see "Measure Cell Voltages Manual" in order to remove the back case of the unit and measure each of its cell voltages
 - ii. If inconsistent, please use the BMS Adapter Cable along with BMS Tool Software
 - Once the BMS Tool Software is running, check what Alarm is currently active
 - Follow "Troubleshooting Manual"
3. If the problem persists, please contact Fortress Power Tech Support







8. TROUBLESHOOTING

8.1 GENERAL TROUBLESHOOTING GUIDE



ISSUE	SOLUTION
Unit voltage at terminals is extremely low or is bleeding down (steep decline)	Unit's BMS is in Protection Mode. There are two possible solutions. <ol style="list-style-type: none">1. Use a 48V charger to trickle charge the battery in order activate the BMS2. Use the BMS-to-Computer Adapter Cable in conjunction with the BMS Tool Software on a Windows Computer to forcibly reset the Charge/Discharge Relays. Contact Fortress Power Tech Support.
Unit can charge/ discharge healthily but amperage on LCD Display is not accurate	Check amperage on cable with a Clamp Sensor. If consistent with inverter, but not battery, use the BMS-to-Computer Adapter Cable in conjunction with the BMS Tool on a Windows Computer to check BMS Vitals and diagnose situation. If nothing is seen, BMS Tray may need to be taken out. Inspect Main BMS Module for improper solders or burns. Replace if necessary. Contact Fortress Power Tech Support.
"ALARM" LED Light is on but unit still functions	Check Inverter Settings. Use the BMS-to-Computer Adapter Cable in conjunction with the BMS Tool on a Windows Computer to check BMS Vitals and diagnose situation. Follow the below chart (Section 8.2) for solution
"ALARM" LED Light is on but unit cannot function	Try to turn on unit by holding the Power Button. Use the BMS-to-Computer Adapter Cable in conjunction with the BMS Tool on a Windows Computer to check BMS Vitals and diagnose situation. Follow the below chart for solution. Follow the below chart (Section 8.2) for solution
If cells are imbalanced (upon checking with the BMS Tool)	Open Back case and check harness connections are connected properly. Make sure all connections have "Black" wires on the left side (regardless of orientation) and "Red" on the right side. Check voltages of each cell (See "Measure Cell Voltages Manual")
LCD Display went Dark	LCD Display will automatically go dark after 60 seconds of inactivity to preserve energy consumption. If problem persists, open front case and check LCD Display connections.
Whole system (Inverter and Battery) shut off	Check Breaker to see if tripped. Set Breaker to "Off" then turn back to "On". Reset Battery BMS. Try to restart battery by holding down the Power Button. If problem persists, use the BMS-to-Computer Adapter Cable in conjunction with the BMS Tool on a Windows Computer to check BMS Vitals and diagnose situation.

8.2 LCD DISPLAY WARNINGS





ERROR LIST

	over high voltage protection
	over low voltage protection
	Discharge over-temp protection, charge over-temp protection, environmental over-temp protection
	Discharge low-temp protection, charging low-temp protection, environmental low-temp protection
	Discharge over current protection, charge over current protection
	Short circuit protection

8.3 FUNDAMENTAL TROUBLESHOOTING GUIDE

RUNNING STATE	STATUS	RUN	ALM	DISPLAY	SOLUTION
	normal	●	-	-	-
	Battery COM Error		-	Flash -	Check the communication cable and battery ID (Cannot repeat with others) on LCD, then restart.
	Battery Wait for parallel	Flash	-	-	No action necessary. This battery will join in parallel within 1 cycle.
Charge	Total overvoltage alarm	●	-		stop charge
Charge	Total overvoltage protection	-	●		stop charge, start discharge
Charge	Cell over-voltage alarm	●		-	stop charge
Charge	Cell over-voltage protection		●	-	stop charge

RUNNING STATE	STATUS	RUN	ALM	DISPLAY	SOLUTION
Charge	over current alarm	•	-		lower the power used
Charge	over current protection	-	•		disconnect the battery and turn it on after lowering the power
Discharge	total low-voltage alarm	•	-		start charging
Discharge	total low-voltage protection	-	•		charging activation
Discharge	cell low-voltage alarm	•	-	-	start charging
Discharge	cell low-voltage protection	-	•	-	charging activation
Discharge	over current alarm	•	-		lower the power used
Discharge	over current protection	-	•		disconnect the battery, stop using the battery, and reset BMS once within a safe range
Temperature	charge over-temperature alarm	•	-		reduce the environment temperature, lower the power used
Temperature	charge over-temperature protection	-	•		disconnect the battery, stop using the battery, and reset BMS once within a safe range
Temperature	charge low-temperature alarm	•	-		reduce the environment temperature
Temperature	charge low-temperature protection	-	•		disconnect the battery, stop using the battery, and reset BMS once within a safe range
Temperature	discharge over-temperature alarm	•	-		reduce the environment temperature
Temperature	discharge over-temperature protection	-	•		disconnect the battery, stop using the battery, and reset BMS once within a safe range
Temperature	discharge low-temperature alarm	•	-		improve the environment temperature
Temperature	discharge low-temperature protection	-	•		disconnect the battery, stop using the battery, and reset BMS once within a safe range

RUNNING STATE	STATUS	RUN	ALM	DISPLAY	SOLUTION
Temperature	environment over temperature alarm	•	-		reduce the environment temperature
Temperature	environment over temperature protection	-	•		reduce the environment temperature
Temperature	environment low temperature alarm	•	-		improve the environment temperature
Temperature	environment low temperature protection	-	•		improve the environment temperature

About Fortress Power

Our mission is to provide compact, user-friendly, and affordable energy storage solutions using the latest technology for all homes and businesses. Fortress solar energy storage batteries can easily integrate with new and existing PV systems and work with a wide range of existing inverter and charge controller manufacturers for ease in system design.

Contact Information

Address:

Corporate Headquarters
505 Keystone Rd
Suite D
Southampton, PA 18966 USA

Website: www.fortresspower.com

Phone: (877) 497-6937

Legal

Fortress Power assumes no responsibility or liability for loss or damage, whether direct, indirect, consequential or incidental, which might arise out of the use of this information. Use of this information is entirely at the user's risk.

Fortress Power cannot be responsible for system failure, damages, or injury resulting from improper installation of their products. Information included in this document is subject to change without notice.

© 2021 by Fortress Power LLC. All Rights Reserved.

For recycling information please contact Fortress Power

