

<b>Prüfbericht-Nr.:</b> <i>Test Report No.:</i>	<b>CN22M2ZQ 001</b>	<b>Auftrags-Nr.:</b> <i>Order No.:</i>	168372872	Seite 1 von 39 Page 1 of 39
<b>Kunden-Referenz-Nr.:</b> <i>Client Reference No.:</i>	2334702	<b>Auftragsdatum:</b> <i>Order date:</i>	2022.05.17	
<b>Auftraggeber:</b> <i>Client:</i>	<b>Fortress Power LLC</b> 505 Keystone Road, Southampton, PA 18966			
<b>Prüfgegenstand:</b> <i>Test item:</i>	Battery rack			
<b>Bezeichnung / Typ-Nr.:</b> <i>Identification / Type No.:</i>	DuraRack			
<b>Auftrags-Inhalt:</b> <i>Order content:</i>	Test -report			
<b>Prüfgrundlage:</b> <i>Test specification:</i>	UL 9540A: 2019 (Fourth Edition)			
<b>Wareneingangsdatum:</b> <i>Date of sample receipt:</i>	2022.05.10			
<b>Prüfmuster-Nr.:</b> <i>Test sample No.:</i>	Engineering sample			
<b>Prüfzeitraum:</b> <i>Testing period:</i>	2022.05.10 ~ 2022.05.24			
<b>Ort der Prüfung:</b> <i>Place of testing:</i>	Refer to clause 1.1 of main report			
<b>Prüflaboratorium:</b> <i>Testing laboratory:</i>	Refer to clause 1.1 of main report			
<b>Prüfergebnis*:</b> <i>Test result*:</i>	See main report			
<b>erstellt von:</b> <i>created by:</i>	<b>genehmigt von:</b> <i>authorized by:</i>			
<b>Datum:</b> 2022.08.29 <i>Date:</i>	 Xun Yu	<b>Datum:</b> 2022.08.29 <i>Date:</i>	 Corney Zhang	
<b>Stellung / Position</b>	Project Engineer	<b>Stellung / Position</b>	Technical Certifier	
<b>Sonstiges /</b> <i>Other:</i>	This report does not evidence compliance of the provided sample with the relevant standards but only with the referred tests. This test report documents the findings of examination conducted on the delivered product mentioned above only. This report does not entitle the applicant to carry any safety mark on this or similar products. Further for sales or other application purposes of the tested product, any reference to TÜV Rheinland or a test through TÜV Rheinland is only permissible with prior written consent of TÜV Rheinland.			
<b>Zustand des Prüfgegenstandes bei Anlieferung:</b> <i>Condition of the test item at delivery:</i>	Prüfmuster vollständig und unbeschädigt <i>Test item complete and undamaged</i>			
* Legende:	P(ass) = entspricht o.g. Prüfgrundlage(n)	F(ail) = entspricht nicht o.g. Prüfgrundlage(n)	N/A = nicht anwendbar	N/T = nicht getestet
*Legend:	P(ass) = passed a.m. test specification(s)	F(ail) = failed a.m. test specification(s)	N/A = not applicable	N/T = not tested
<p><b>Dieser Prüfbericht bezieht sich nur auf das o.g. Prüfmuster und darf ohne Genehmigung der Prüfstelle nicht auszugsweise vervielfältigt werden. Dieser Bericht berechtigt nicht zur Verwendung eines Prüfzeichens.</b></p> <p><i>This test report only relates to the a. m. test sample. Without permission of the test center this test report is not permitted to be duplicated in extracts. This test report does not entitle to carry any test mark.</i></p>				

v05

## INTRODUCTION

Model fire codes and energy storage system standards require energy storage systems to comply with UL 9540, which in turn requires battery cells and modules to comply with UL 1973. Compliance with these standards reduces the risk of batteries and battery energy storage systems (BESS) creating fire, shock or personal injury hazards. However, they don't evaluate the ability of the BESS installed as intended and with fire suppression mechanisms in place if necessary, from contributing to a fire or explosion in the end use installations.

To address these fire and explosion hazards associated with the installation of a BESS, the fire and other codes require energy storage systems to meet certain location, separation, fire suppression and other criteria. Those codes also provide a means to provide an equivalent level of safety based on large scale fire testing of anticipated BESS installations.

UL 9540A is intended to provide a test method that can be used as a basis for validating the safety of a BESS installation in lieu of meeting the specific criteria provided in those codes. The data generated can be used to determine the fire and explosion protection required for installation of a BESS.

The test method is initiated through the establishment of a thermal runaway condition that leads to combustion within the BESS. The test method outlined in UL 9540A consists of several steps – cell level testing, module level testing, unit level testing and installation level testing. The cell and module level testing steps are information gathering steps to inform the unit and installation level testing.

The following outlines the information that may be gathered as part of the testing:

- a) Cell level – An individual cell fails in a manner that leads to thermal runaway and fire through a suitable method such as external heating. Data such as off-gassing contents, temperatures at venting and temperatures at thermal runaway are recorded.
- b) Module level – One or more cells within a BESS module fail in the manner determined during the cell level testing. Data such as fire propagation in the module, temperatures on the failed cells and surrounding cells, off-gassing contents and heat release data are gathered.
- c) Unit level – A complete BESS is installed surrounded by target (e.g. dummy) BESS and walls separated at a distance as intended in its installation. The module level test is repeated on a module located in the BESS in the most unfavorable location. Data such as temperature within the BESS, on surrounding walls and target BESS; incident heat flux on walls and target BESS; observation of fire propagation from BESS to target units and walls as well as observance of explosions or evidence of re-ignition within the BESS; and heat release and off-gassing contents are gathered.
- d) Installation level – This test is a repeat of the unit level test with the test conducted within a test room and with the intended fire suppression system installed as well as any overhead cables (that can lead to fire propagation) installed. This test is intended to validate the fire suppression system for the BESS installation. Data such as temperature within the BESS, on surrounding walls and target BESS; incident heat flux on walls and target BESS; fire propagation from the BESS to target units, walls or overhead cables and any observable explosion incidents or re-ignition within the BESS; and off-gassing contents (if needed) and heat release are gathered.

## Contents

<b>1</b>	<b>GENERAL INFORMATION .....</b>	<b>4</b>
1.1	TEST SPECIFICATION .....	4
1.2	GENERAL REMARKS .....	4
1.3	REVISION INFORMATION .....	4
	NEW REPORT, NOT APPLICABLE. ....	4
1.4	DEFINITIONS .....	5
<b>2</b>	<b>GENERAL PRODUCT INFORMATION .....</b>	<b>6</b>
2.1	CELL .....	6
2.2	MODULE .....	6
2.3	BATTERY RACK .....	7
2.4	PHOTO.....	9
<b>3</b>	<b>UNIT LEVEL TEST (SECTION 9 OF UL 9540A) .....</b>	<b>11</b>
3.1	GENERAL .....	11
3.2	UNIT SAMPLE PREPARATION.....	12
3.3	SETUP OF THE TEST .....	12
3.3.1	<i>Battery system installation information</i> .....	12
3.3.2	<i>Test site setup</i> .....	13
3.3.3	<i>Thermal runaway setup</i> .....	14
3.4	OBSERVATIONS AND RECORDS .....	16
3.4.1	<i>Temperature measurement</i> .....	17
3.4.2	<i>Temperature measurement of modules surface in unit</i> .....	19
3.4.3	<i>Temperature measurement of instrumented wall</i> .....	21
3.5	HEAT FLUX MEASUREMENT .....	24
3.6	GAS GENERATION MEASUREMENT .....	26
3.6.1	<i>Test method</i> .....	26
3.6.2	<i>Total gas release</i> .....	26
3.6.3	<i>Gas components</i> .....	27
	..... <i>Error! Bookmark not defined.</i>	
3.7	PERFORMANCE SUMMARY REMARK AGAINST CRITERIA.....	33
3.8	PHOTOS.....	34
<b>4</b>	<b>LIST OF TEST AND MEASUREMENT INSTRUMENTS .....</b>	<b>38</b>

## 1 General information

### 1.1 Test specification

**Standard: ANSI/CAN/UL 9540A: 2019 (Fourth Edition)**

**Test Method for Evaluating Thermal Runaway Fire Propagation in Battery Energy Storage Systems**

This report presents the result of unit level tests of UL 9540A: 2019.

All tests were conducted at TÜV Rheinland (Shenzhen) Co., Ltd. and TÜV Rheinland's partner labs that were under supervision of TÜV Rheinland's engineer.

Testing period: May 10, 2022 ~ May 13, 2022

Refer to Clause 4 for test and measurement instruments.

### 1.2 General remarks

This report is descriptive and provide the test data only.

The test results presented in this report relate only to the object tested.

This report shall not be reproduced, except in full, without the written approval of the testing laboratory.

Throughout this report a  comma /  point is used as the decimal separator.

### 1.3 Revision information

New report, not applicable.

## 1.4 Definitions

**CELL** – The basic functional electrochemical unit containing an assembly of electrodes, electrolyte, separators, container, and terminals. It is a source of electrical energy by direct conversion of chemical energy.

**MODULE** – A subassembly that is a component of a BESS that consists of a group of cells or electrochemical capacitors connected together either in a series and/or parallel configuration (sometimes referred to as a block) with or without protective devices and monitoring circuitry.

**UNIT** – A frame, rack or enclosure that consists of a functional BESS which includes components and subassemblies such as cells, modules, battery management systems, ventilation devices and other ancillary equipment.

**BATTERY SYSTEM (BS)** – Is a component of a BESS and consists of one or more modules typically in a rack configuration, controls such as the BMS and components that make up the system such as cooling systems, disconnects and protection devices.

**BATTERY ENERGY STORAGE SYSTEM (BESS)** – Stationary equipment that receives electrical energy and then utilizes batteries to store that energy to supply electrical energy at future time. The BESS, at a minimum consists of one or more modules, a power conditioning system (PCS), battery management system (BMS) and balance of plant components.

a) **INITIATING BATTERY ENERGY STORAGE SYSTEM UNIT (INITIATING BESS)** – A BESS unit which has been equipped with resistance heaters in order to create the internal fire condition necessary for the installation level test.

b) **TARGET BATTERY ENERGY STORAGE SYSTEM UNIT (TARGET BESS)** – The enclosure and/or rack hardware that physically supports and/or contains the components that comprise a BESS. The target BESS unit does not contain energy storage components, but serves to enable instrumentation to measure the thermal exposure from the initiating BESS.

**Note:** Depending upon the configuration and design of the BESS (e.g. the BESS is composed of multiple separate parts within separate enclosures), the unit level test can be done at battery system level. In such case, the BESS is be read as BS throughout this report.

**NON-RESIDENTIAL USE** – Intended for use in commercial, industrial or utility owned locations.

**RESIDENTIAL USE** – In accordance with this standard, intended for use in one or two family homes and town homes and individual dwelling units of multi-family dwellings.

**THERMAL RUNAWAY-** The incident when an electrochemical cell increases its temperature through self-heating in an uncontrollable fashion. The thermal runaway progresses when the cell's generation of heat is at a higher rate than the heat it can dissipate. This may lead to fire, explosion and gas evolution.

**STATE OF CHARGE (SOC)** – The available capacity in a BESS, pack, module or cell expressed as a percentage of rated capacity.

## 2 General Product Information

The product information and parameters were provided by the client as below.

### 2.1 Cell

Manufacturer .....	[REDACTED]	
Model .....	[REDACTED]	
Chemistry .....	LiFePO4	
Physical configuration .....	Prismatic	
	Weight:	1.98±0.06 kg
	Dimension:	130.3±1.0*36.7±1.0*20 0.5±1.0 mm
Electrical rating .....	Rated capacity:	105 Ah
	Nominal voltage:	3.2V
Standard charge method .....	Charge current:	52.5 A
	End of charge voltage:	3.65 V
	Cut off current:	5.25
Standard discharge method .....	Discharge current:	52.5 A
	End of discharge voltage:	2.5 V

### 2.2 Module

Manufacturer name .....	Fortress Power LLC	
Model number .....	eFlex 5.4	
Physical configuration .....	Metal enclosure	
	Weight:	51.8 kg
	Cells in series/parallel:	1P16S
	Total number of cells:	16
Cooling method .....	Forced air cooling	
Separation between cells .....	No	
Electrical rating .....	Rated capacity:	105 Ah
	Nominal voltage:	51.2 V
Standard charge method .....	Charge current:	55 A
	End of charge voltage:	58.4 V
Standard discharge method .....	Discharge current:	<68 A

	End of discharge voltage: 48 V
Compliance with UL 1973.....:	Report no. 200117076GZU-001, issued by Intertek Testing Services Shenzhen Ltd. Guangzhou Branch.

## 2.3 Battery rack

Manufacturer:	Fortress Power LLC
Model number .....	LiFePO4 (51.2V 105Ah)
Physical configuration.....:	Metal enclosure
	(1P16S)4p
	Weight of system: 280 kg
	Vertical separation between modules: 490 mm
	Horizontal separation between modules: 0 mm
Electrical rating .....	Rated capacity: 420 Ah
	Nominal voltage: 51.2 V
Compliance with UL9540.....:	<input type="checkbox"/> Yes <input checked="" type="checkbox"/> No
Compliance with UL1973.....:	<input type="checkbox"/> Yes <input checked="" type="checkbox"/> No
Integrated fire protection system in the unit.....:	<input type="checkbox"/> Yes integrated fire protection system <input checked="" type="checkbox"/> No

Unit diagram with overall dimension

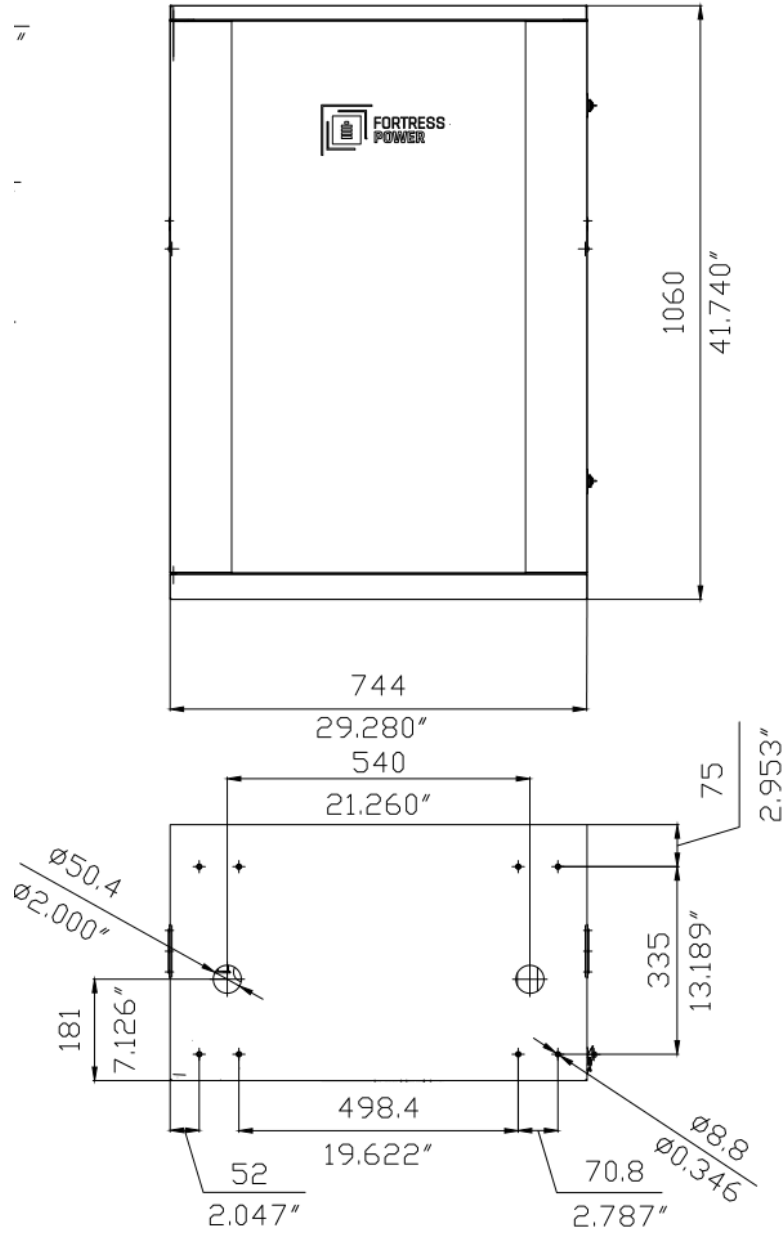

Unit: mm

## 2.4 Photo

Module



Rack



## **3 Unit level test (section 9 of UL 9540A)**

### **3.1 General**

Unit level testing corresponds with the testing anticipated by fire codes and other codes impacting energy storage system installations to evaluate the large scale fire performance of BESS units installed in, on or adjacent to buildings or in other areas and their resultant performance to qualify for exceptions to limits in the codes imposed on these installations. The limitations where exceptions may be sought are limitations on the size of the individual BESS units, the total number of BESS units installed within a room, and the separation distances between BESS units and between BESS units and walls of the building.

In this test the initiating BESS unit is placed a set distance from target BESS units simulating BESS units identical to the initiating BESS unit, and from simulated walls representative on the installation. A thermal runaway is induced in cells, using the same approach as used in the module level testing within one of the modules in the initiating BESS, and a variety of measurements are taken. The results are intended to be used to verify that a fire within a single BESS unit will not spread to other units, nor breach the walls or the BESS enclosure (if provided), and there shall be no flying debris or explosive discharge of gases.

The test arrangement include the largest (energy) BESS unit for the installation to be represented by the test, and minimum spacing to adjacent walls and BESS units. The BESS may be tested with an internal fire suppression system provided by the manufacturer if that fire suppression system is required to be installed in the BESS. Optional internal fire suppression systems are not included in the unit level testing.

The test monitors the fire behavior of the BESS unit and measures heat release rates (convective and chemical); gas generation and composition; smoke release rate; maximum heat flux on the target BESS units, wall surfaces and within the accessible means of egress; maximum surface temperatures of the walls and modules within the target BESS units; and documents any explosions, deflagrations and flying debris from the BESS under test.

### 3.2 Unit sample preparation

The battery rack is constructed with 4 modules that was considered as a unit for purposes of the test.

All 4 modules samples through 3 charge/discharge cycles per the manufacturer's instructions to verify that the module was functional. Each cycle was defined as a charge to 100% SOC and allowed to rest 30 minutes and then discharged to an end of discharge voltage (EODV) determined by the module specification. Refer to 2.2 for the end of condition of charge and discharge.

### 3.3 Setup of the test

#### 3.3.1 Battery system installation information

The installation information was provided by the client as below.

Intended use location .....	<input checked="" type="checkbox"/> Residential	<input type="checkbox"/> Non-residential
	<input type="checkbox"/> Non-residential rooftop	
	<input type="checkbox"/> Non-residential open garage use	
Type of installation.....	<input checked="" type="checkbox"/> Indoor	<input type="checkbox"/> Outdoor
	<input checked="" type="checkbox"/> Floor/ground mounted	<input type="checkbox"/> Wall mounted
Row(s) of installation	<input checked="" type="checkbox"/> Single	<input type="checkbox"/> Multiple

### 3.3.2 Test site setup

Two instrumented wall with 3.66 m height, 4.1 m length. Walls were constructed of 19.05-mm(3/4-in) plywood and painted flat black.

Two rack were used for the purpose of the test.

The initiating unit was positioned adjacent to the two instrumented wall sections.

Minimum separation distance from the unit to wall and between unit were provided by the client, separation distance: A=B=C=D=1 inch.

Unit's layout can be seen in Figure 1.

Figure 1. Top view of sub-unit's layout

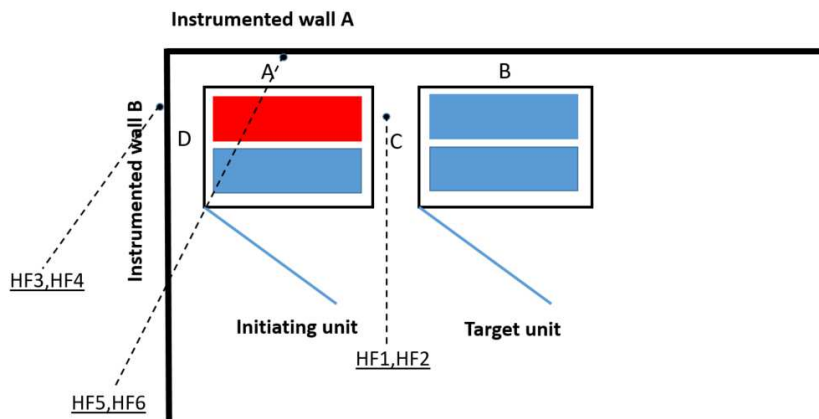

Separation Distance : A=B=C=D=1 inch

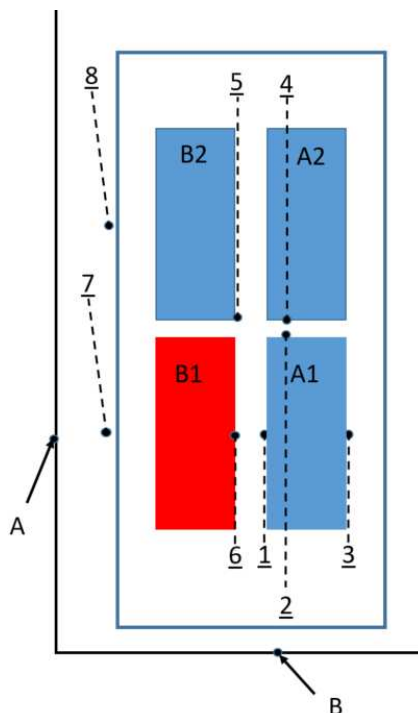

### 3.3.3 Thermal runaway setup

Setup of Unit:

There were 4 columns module in the rack, and two rack was marked as initiating unit and target unit, respectively.

Modules **B1** was selected as “initiating module” for the test in initiating unit.

Modules **A1/B2 and D1** were used to check the possible propagation between modules in initiating unit and target unit. Figure 2 show the details.

Figure 2. Module numbering in unit

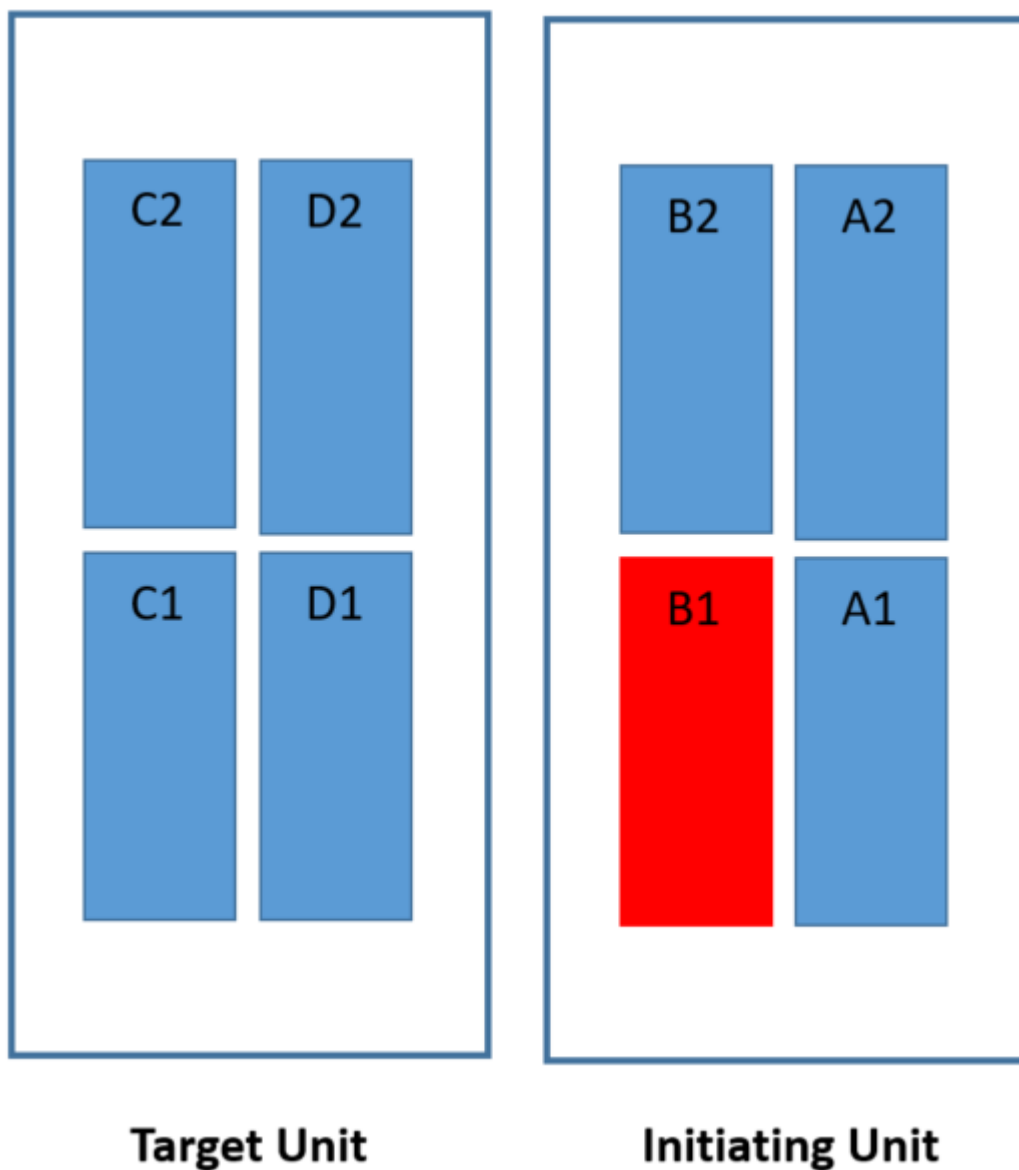

Side view of initiating unit and target unit

One heater, controlled by a PID heating controller; The PID controller were used to control the voltage supply to the heater and maintain a 4°C/min to 7°C/min heating rate.

The heater was de-energized immediately and independently as the thermal runaway observed on the cell that is heat by the heater.

Setup of module:

The module to be tested was charged to 100% SOC and allowed to stabilize for a minimum of 1 h and a maximum of 8 h before the start of the test.

The module consisted of 16 cells(1P16S). All cells in the module were numbered from #1 to #16 as below.

External heating method was used to initiate thermal runaway in the module. Two PI sheet heater rated 75VAC/300 W, size 150\*100 mm, were fitted on cell.

Total 13 PTFE insulated thermocouples, Type K, 24AWG, were attached between the cells and under the heating surface. Temperature of both sides were monitored during test. See Figure 2 for the detail locations.

Schematic diagram can be seen as follow:

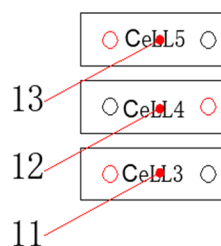
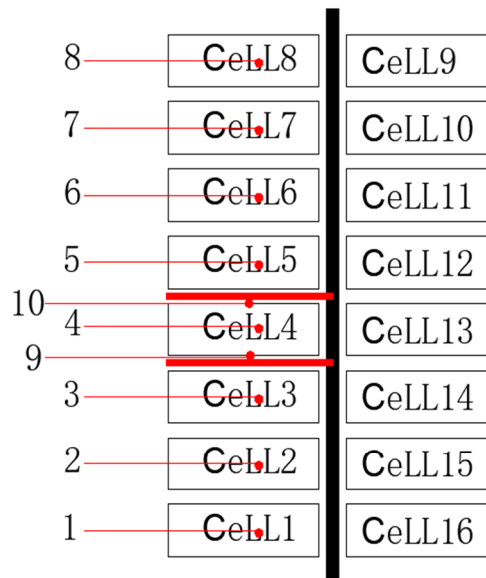

### 3.4 Observations and records

Before test, the initiating module was charged to 100% SOC and allowed to stabilize for a minimum of 1 h and a maximum of 8 h before the start of the test.

Ambient condition at the initiation of the test was 28°C, 53% R.H

Open circuit voltage of the modules before test was recorded as below:

Before the test:				
Number of module in Initiating unit	A1	A2	B1	B2
OCV (V)	53.1	53.2	53.2	53.2
Weight (kg)	51.0	51.2	51.6	51.2

Test was performed on 2022.05.12, started at 06:30 PM.

Observations during test:

White smoke was observed 87 minutes after test was initiated.

Time	Item
06:30 PM	Start test
07:57 PM	Smoke observed first time on Module B1

No flying debris or explosive discharge of gases during test.

No sparks, electrical arcs, or other electrical events during test.

No external flaming was observed.

Observations after test:

No damage on target walls.

No damage on target units.

The initiating cells (#3 ~ #5) of Module B13 were damaged(thermal runaway) after the test. Cells #1~2 and #6~8 damaged because of the propagation by cell to cell.

After the test:				
Initiating module number	A1	A2	B1	B2
OCV (V)	53.1	53.2	20.19	53.2
Weight (kg)	51.0	51.2	49.2	51.2

Weight loss of the initiating module A3 was 2.4 kg (before test 51.6 kg, after test 41.2 kg)

### 3.4.1 Temperature measurement

Total 31 glass fiber insulated thermocouples, Type K, 24AWG, were attached on all module and unit. See Figure 3 and Figure 5 for the detailed locations.

Figure 3: Thermocouple locations on module

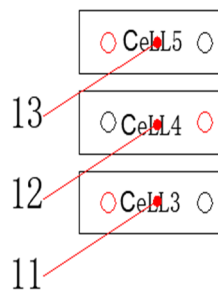
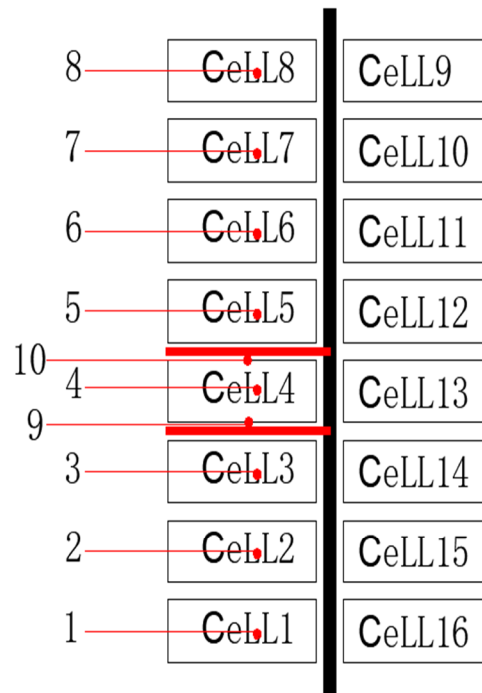

**Module B1**

The thermocouple temperature of the module B1 was shown in the figure 4 as below.

Figure 4. Temperature vs time curve of module B1.

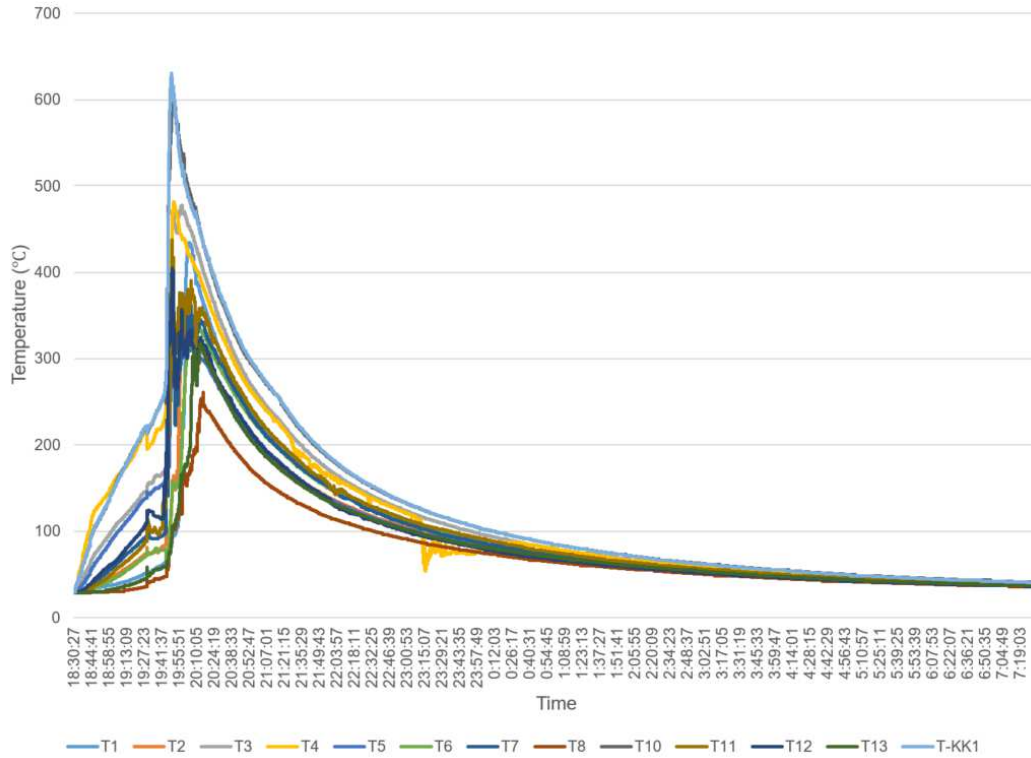

Number	Location	Channel	Max Temp. (°C)
1	#1 cell narrow surface	T1	433.8
2	#2 cell narrow surface	T2	348.6
3	#3 cell narrow surface	T3	477.5
4	#4 cell narrow surface	T4	482.1
5	#5 cell narrow surface	T5	338.1
6	#6 cell narrow surface	T6	337.9
7	#7 cell narrow surface	T7	398.5
8	#8 cell narrow surface	T8	260.8
9	Between #4 wide surface and heater	T-KK1	630.5
10	Between #4 cell wide surface and heater	T10	609.2
11	Vent of 3# cell	T11	437.8
12	Vent of 4# cell	T12	404.6
13	Vent of 5# cell	T13	317.9

Note: the temperature recording started on 2022-05-12 06:30:27 PM (Beijing Time), ended at 2022-05-13 07:19:03 (Beijing Time). Time format hh:mm:ss.ms.

### 3.4.2 Temperature measurement of modules surface in unit

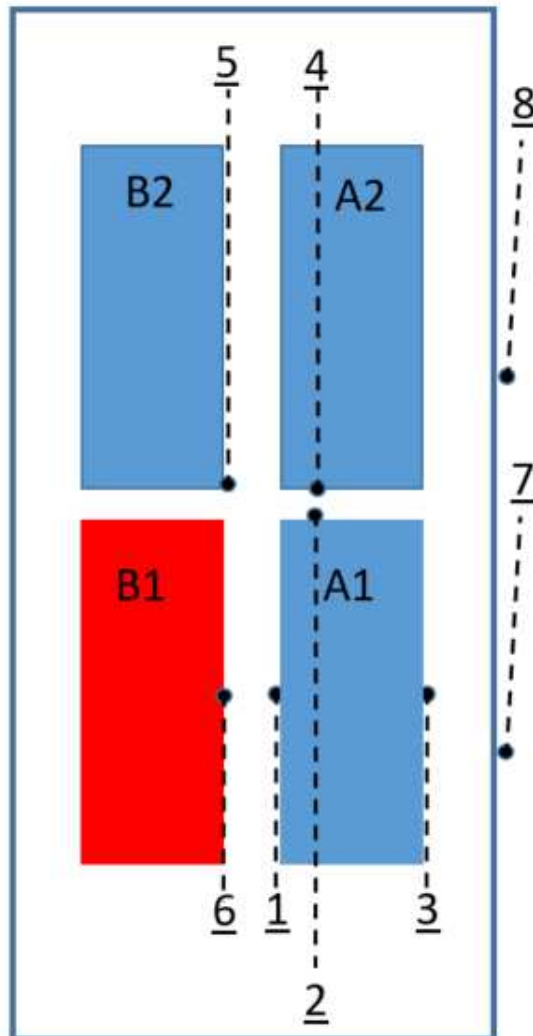

Side view

Figure 5. Surface temperatures of module in unit

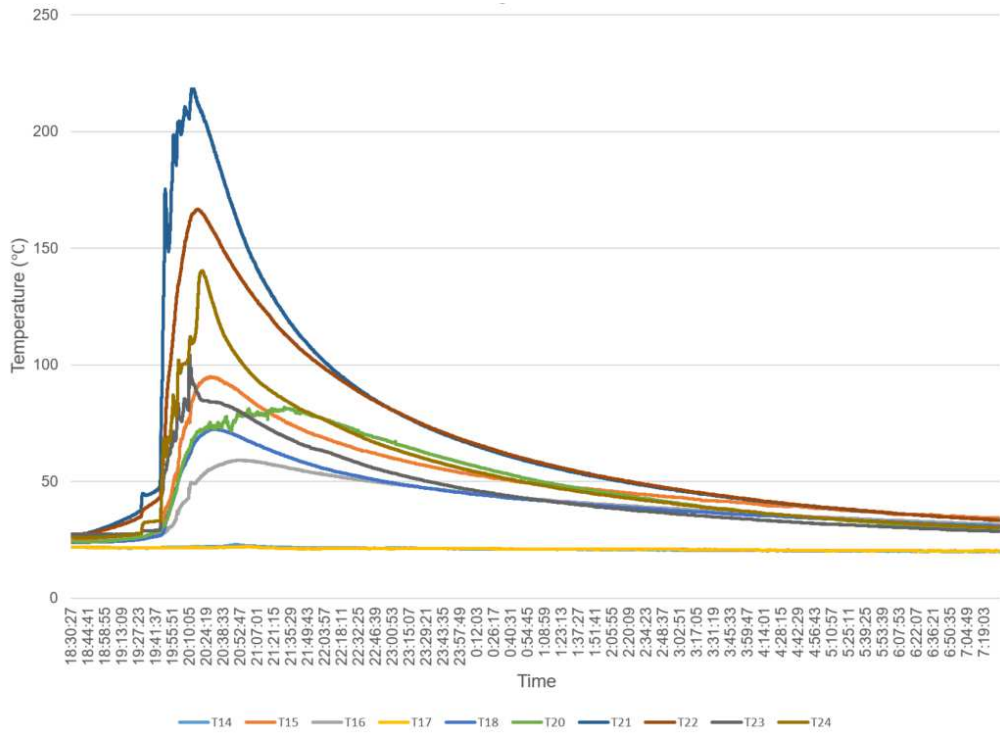

Number	Location	Channel	Max Temp. (°C)
1	Left side of Module A1 adjacent to B1 in initiating unit	T14	22.9
2	Top of Module A1 adjacent to B1 in initiating unit	T15	94.9
3	Right side of Module A1 adjacent to B1 in initiating unit	T16	59.1
4	Bottom of Module A2 adjacent to A1 in initiating unit	T17	22.1
5	Bottom of Module B2 adjacent to B1 in initiating unit	T18	72.4
6	Left side of Module B1	T20	81.9
7	Bottom of Module B1	T21	218.4
8	Right side of Module B1	T22	166.6
9	Front of Module B1	T23	104.3
10	Back of Module B1	T24	140.5

Note: the temperature recording started on 2022-05-12 06:30:27 PM (Beijing Time), ended at 2022-05-13 07:19:03 (Beijing Time). Time format hh:mm:ss.ms.

### 3.4.3 Temperature measurement of instrumented wall

Wall surface temperatures were measured in vertical array at 152 mm intervals for the full height of the instrumented wall sections using Type K, 24 AWG thermocouple. The thermocouple array were collinear with the centre line of initiating unit and target unit.

Figure 6. Temperature of instrumented wall B(Left side of initiating unit)

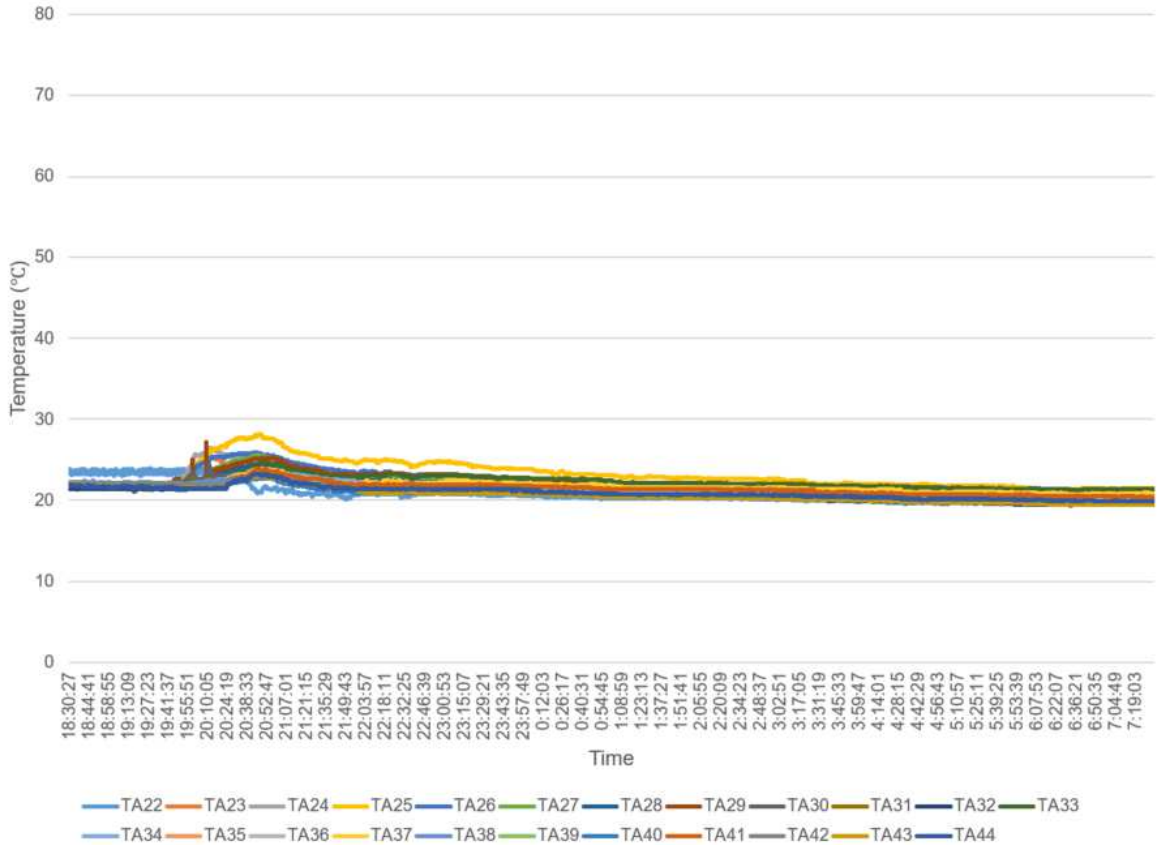

Number	Location	Channel	Max Temp. (°C)
1	Wall B. Vertical array at 152 mm intervals. Left side of Unit1_sub-unitA in the horizontal direction.	TA22	24.1
2		TA23	25.4
3		TA24	26.5
4		TA25	28.1
5		TA26	25.9
6		TA27	25.6
7		TA28	24.5
8		TA29	27.2
9		TA30	24.6
10		TA31	23.5
11		TA32	23.3
12		TA33	24.7
13		TA34	24.0
14		TA35	23.6
15		TA36	23.6
16		TA37	23.9
17		TA38	23.1

18	TA39	22.8
19	TA40	22.7
20	TA41	23.8
21	TA42	23.0
22	TA43	23.0
23	TA44	23.3

Note: the temperature recording started on 2022-05-12 06:30:27 PM (Beijing Time), ended at 2022-05-13 07:19:03 (Beijing Time). Time format hh:mm:ss.ms.

Figure 7. Temperature of instrumented wall A

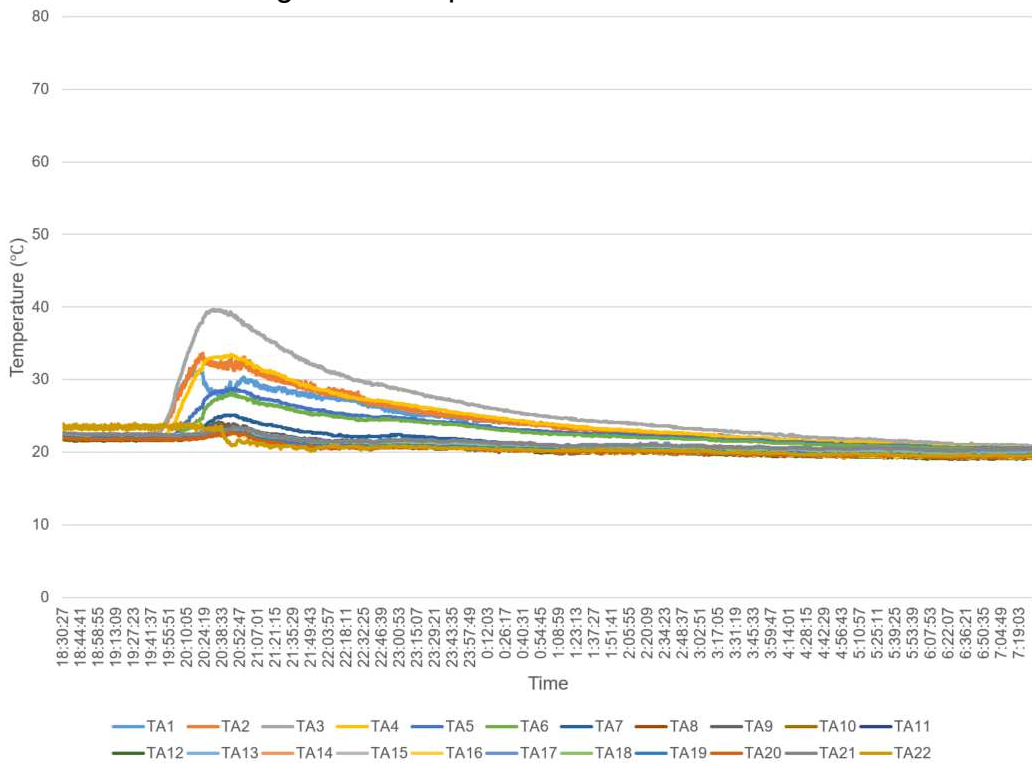

Number	Location	Channel	Max Temp. (°C)
24	Wall A. Vertical array at 152 mm intervals. In front of Unit1_sub-unitA in the horizontal direction.	TA1	31.3
25		TA2	33.6
26		TA3	39.7
27		TA4	33.5
28		TA5	28.8
29		TA6	28.1
30		TA7	25.1
21		TA8	24.1
32		TA9	24.2
33		TA10	23.5
34		TA11	23.1
35		TA12	22.7

**Prüfbericht - Nr.: CN22M2ZQ 001**

Seite 23 von 39

Test Report No.:

Page 23 of 39

36		TA13	23.3
37		TA14	22.8
38		TA15	22.7
39		TA16	22.7
40		TA17	23.4
41		TA18	23
42		TA19	22.8
43		TA20	22.7
44		TA21	23.5
45		TA22	24.1

Note: the temperature recording started on 2022-05-12 06:30:27 PM (Beijing Time), ended at 2022-05-13 07:19:03 (Beijing Time). Time format hh:mm:ss.ms.

### 3.5 Heat flux measurement

Ten sensors were placed on the instrument wall A, wall B and target sub-unit to measure the heat flux.

Two sensors (HFG\_1 & HFG\_2) were placed on sub-unit surface that facing initiating unit.

Two sensors (HFG\_3, HFG\_4) were placed on the surface of instrumented wall B. Two sensors (HFG\_5 & HFG\_6) were placed on the surface of instrumented wall A.

HFG\_3 and HFG\_4 were collinear with the vertical thermocouple array of wall B, adjacent to Initiating unit. HFG\_5 and HFG\_6 were collinear with the vertical thermocouple array of wall A, adjacent to target unit.

Figure 8 shows the sensor positions of wallA and wallB

Figure 8. Heat flux sensor layout

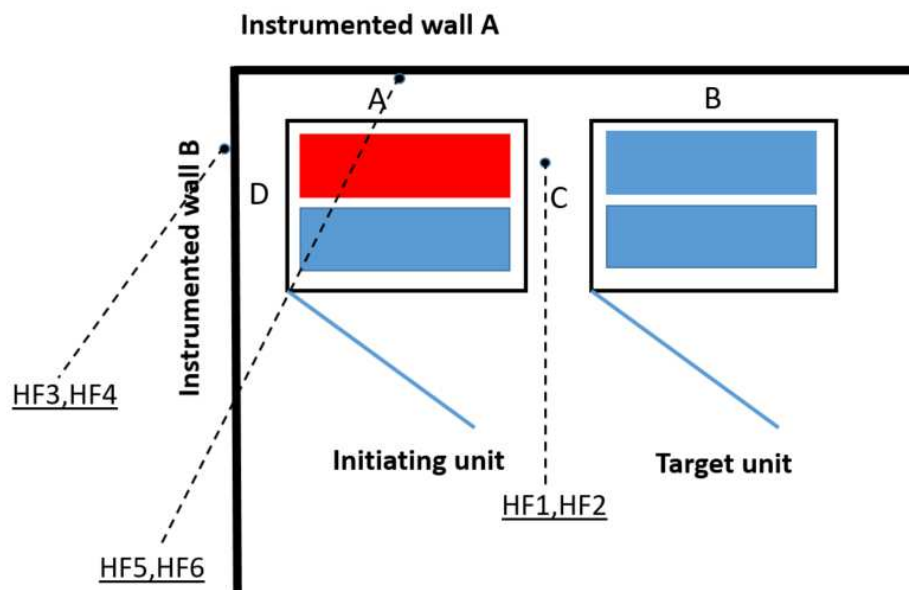

Separation Distance : A=B=C=D=1 inch

Figure 9. The measured heat flux of target walls and target unit

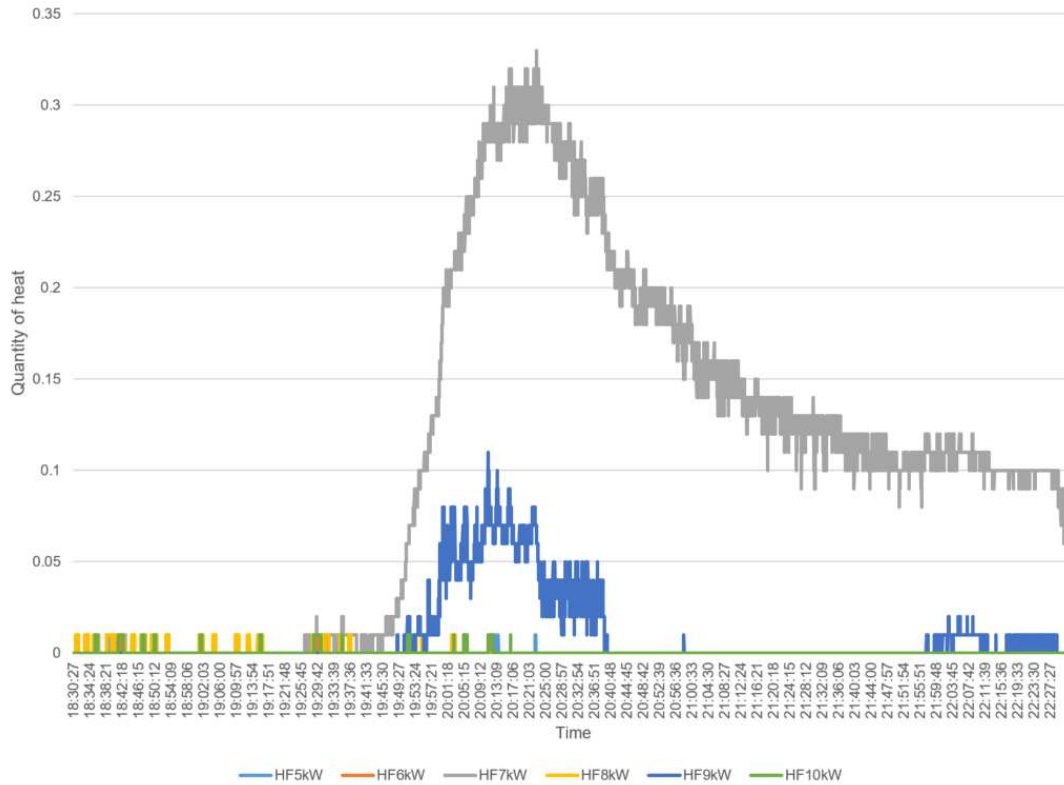

### 3.6 Gas generation measurement

#### 3.6.1 Test method

The composition, velocity and temperature of the vent gases were measured within the calorimeter's exhaust duct.

Gas composition were measured using a Fourier-Transform Infrared Spectrometer with a resolution of  $1 \text{ cm}^{-1}$  and a path length of 4.2 m within the calorimeter's exhaust duct.

The hydrocarbon content of the vent gas was measured using flame ionization detection.

Hydrogen gas was measured with a palladium-nickel thin-film solid state sensor.

Composition, velocity and temperature instrumentation were collocated with heat release rate calorimetry instrumentation

#### 3.6.2 Total gas release

Gas type	Gas components		Total volume of gas (L)
Hydrocarbon species	Methane	CH <sub>4</sub>	17.9
	Ethylene	C <sub>2</sub> H <sub>4</sub>	7.0
	Ethane	C <sub>2</sub> H <sub>6</sub>	2.9
	Propylene	C <sub>3</sub> H <sub>6</sub>	8.5
	Propane	C <sub>3</sub> H <sub>8</sub>	5.3
Others	Carbon Monoxide	CO	1.5
	Carbon Dioxide <sup>2)</sup>	CO <sub>2</sub>	4213.3
	Hydrogen	H <sub>2</sub>	104.9
	Ethylmethyl Carbonate	C <sub>4</sub> H <sub>8</sub> O <sub>3</sub>	41.2
	Dimethyl carbonate	C <sub>3</sub> H <sub>6</sub> O <sub>3</sub>	0.3
Total Hydrocarbons (measured by FID)			103.6

Note: 1) The collection time is from 06:30:27 PM to 10:30:57 PM

2) The carbon dioxide in the air during this period<sup>1)</sup> was also counted

### 3.6.3 Gas components

Concentration of different gas components were present according to gas species classification in Figures 10 to 14. Average flow rate was 2.1 m<sup>3</sup>/S during test.

Figure 10 Hydrocarbon species:

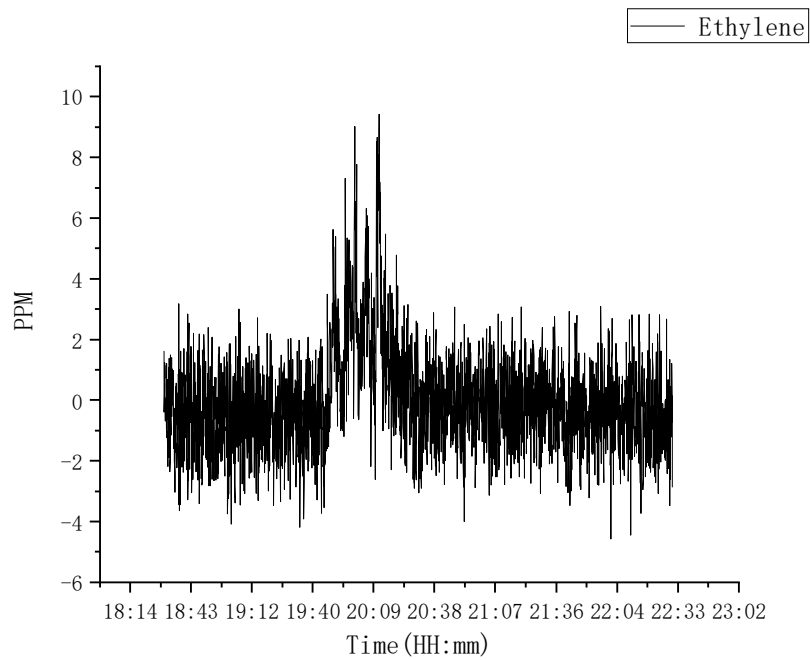
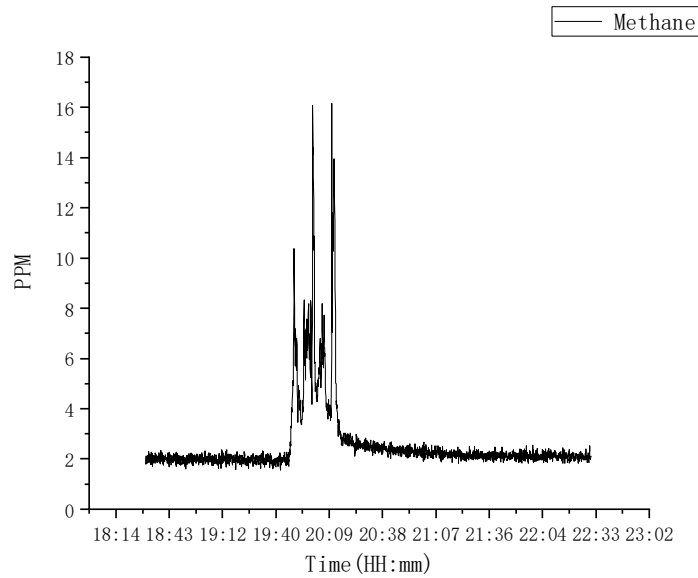

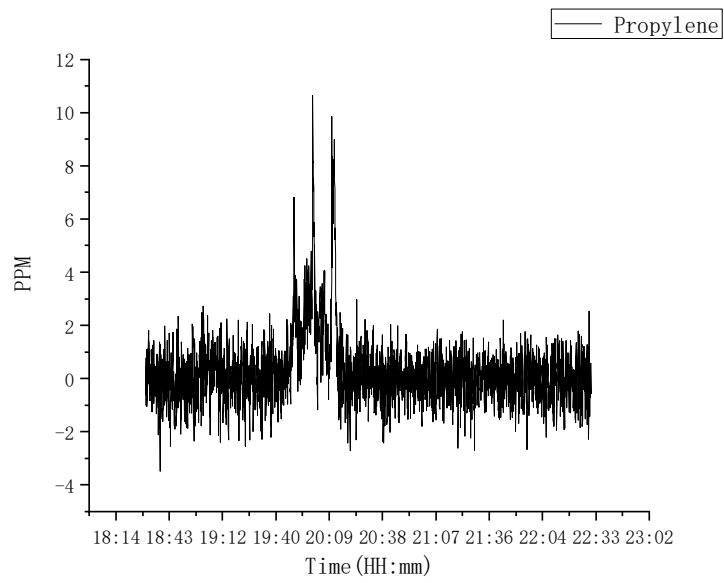
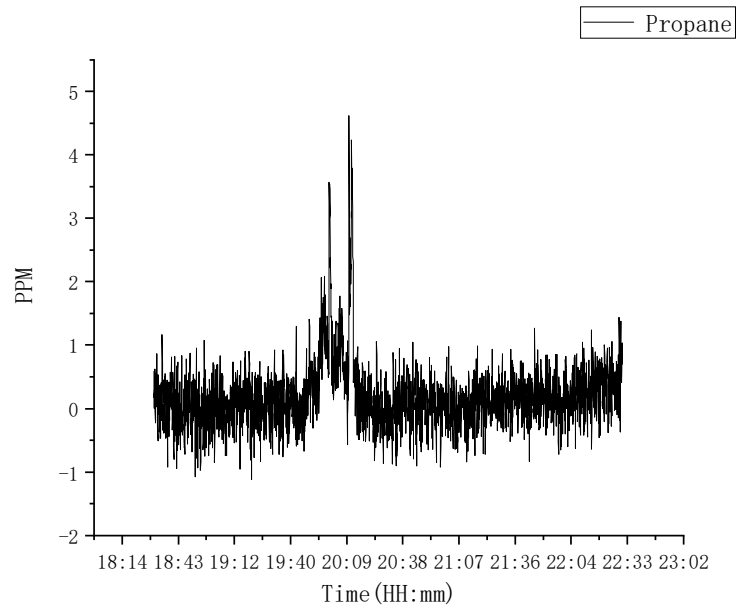

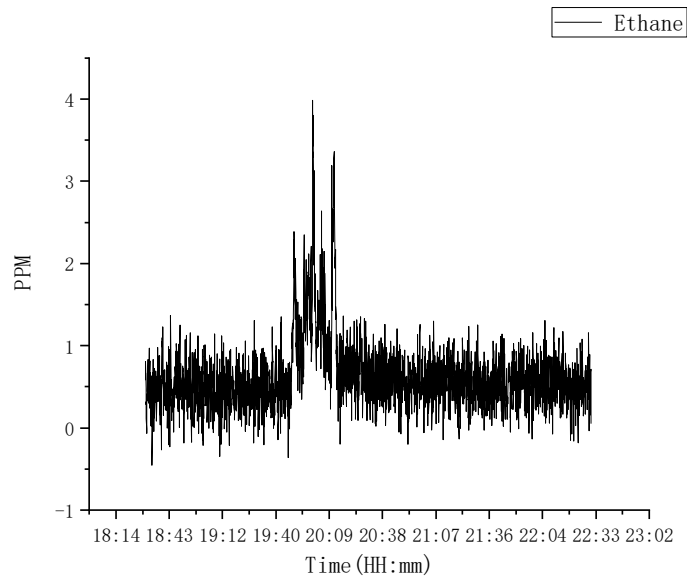
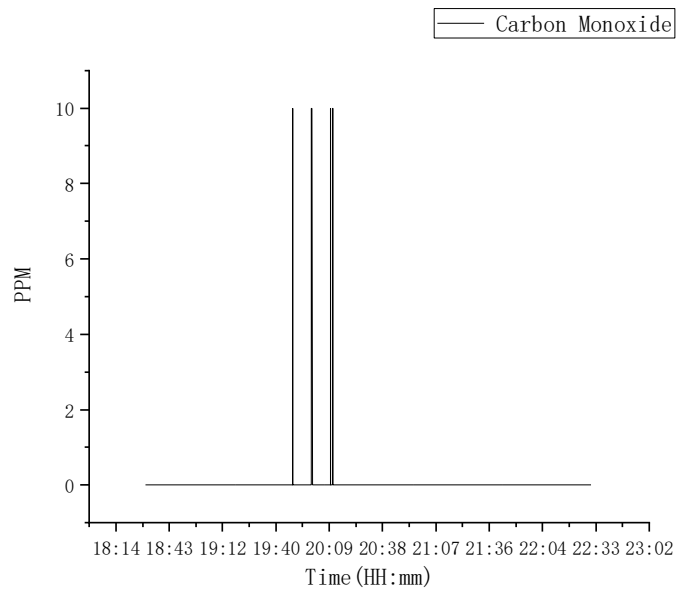
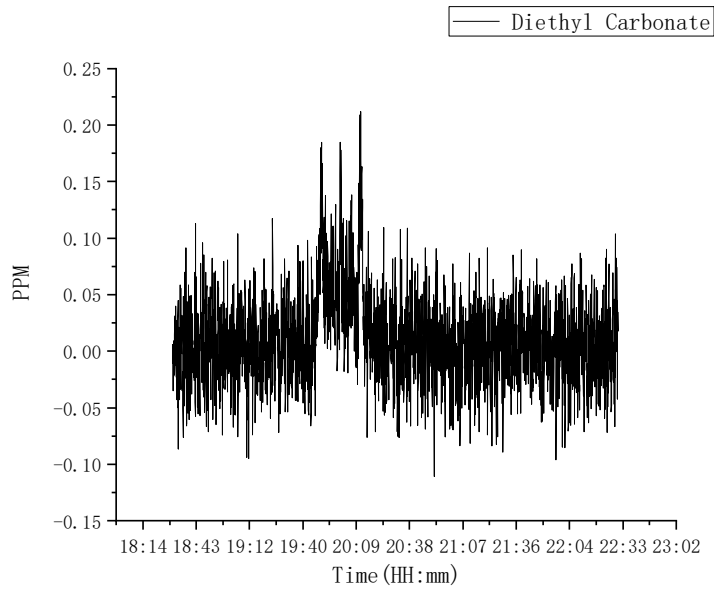
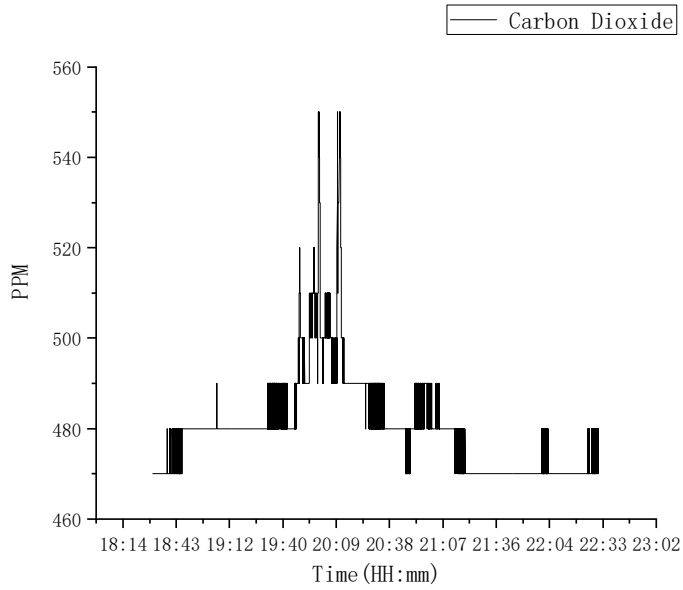

Figure 11 Others





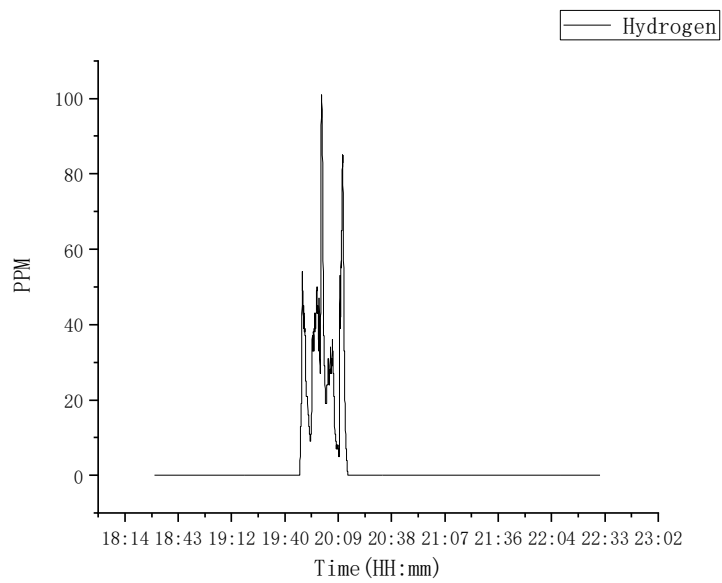
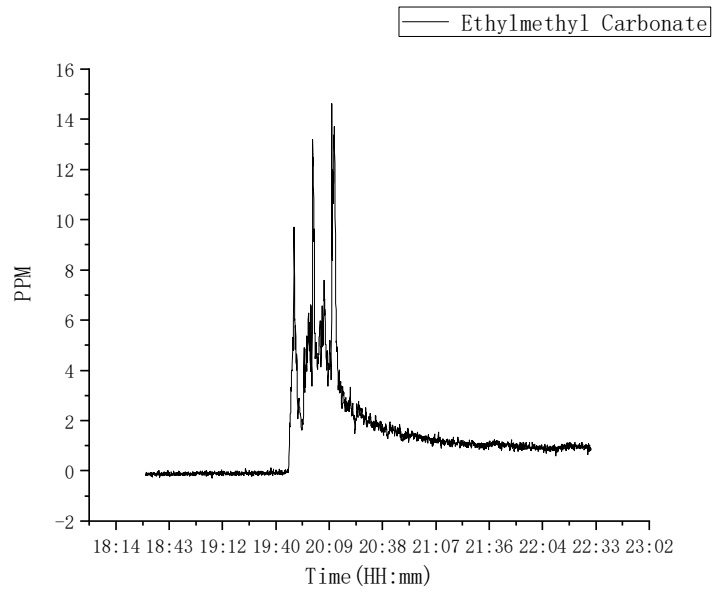
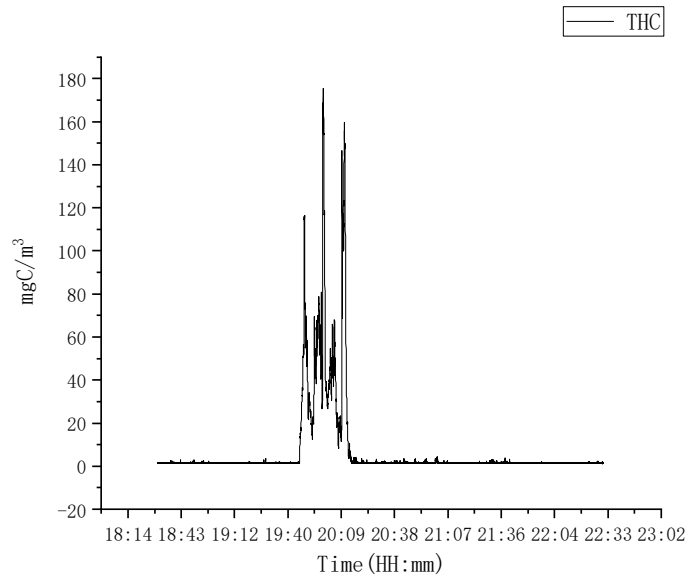

Figure 12 Total Hydrocarbons



### 3.7 Performance Summary Remark Against Criteria

Installation level testing was not required as the following performance conditions were met during the unit level test.

Performance conditions	Remark
a) If flaming outside of the unit observed, separation distances to exposures shall be determine by greatest flame extension observed during test. <i>(No flaming)</i>	No flaming observed in both external and internal of unit during the test.
b) Surface temperatures of modules within the target units adjacent to the initiating unit do not exceed the temperature at which thermally initiated cell venting occurs. <i>(Surface temperatures of module in unit2 and unit3; sub-module A,C,D,F, module B1, B3, B4, E1, E3, E4 in unit1 do not exceed the temperature at which thermally initiated cell venting occurs)</i>	The maximum surface temperature of module within the initiating unit, adjacent to the initiating module was 94.9 °C; the maximum surface temperature of module within the target unit was 40.9 °C, far below the cell venting temperature 200°C.
c) For units intended for installation near exposures, surface temperature measurements on wall surfaces do not exceed 97°C of temperature rise above ambient. <i>(Temp. measured on wall 1, wall 2 and unit3 surface close to unit 1 shall not exceed 97°C+ambient temp.)</i>	Surface temperature rise measurements on wall surfaces and target unit surface adjacent to unit1 was 39.7°C, far below the 97°C.
d) Explosion hazards are not observed, including deflagration, detonation or accumulation of battery vent gases; <i>(The explosion shall not be observed)</i>	Explosion hazards were not observed in both external and internal of unit, during the test.
e) Heat flux in the center of the accessible means of egress shall not exceed 1.3kW/m <sup>2</sup>	No attributable heat flux detected, see clause 3.5 of this report.

### 3.8 Photos

See photo documents

Before the test:





During the test:

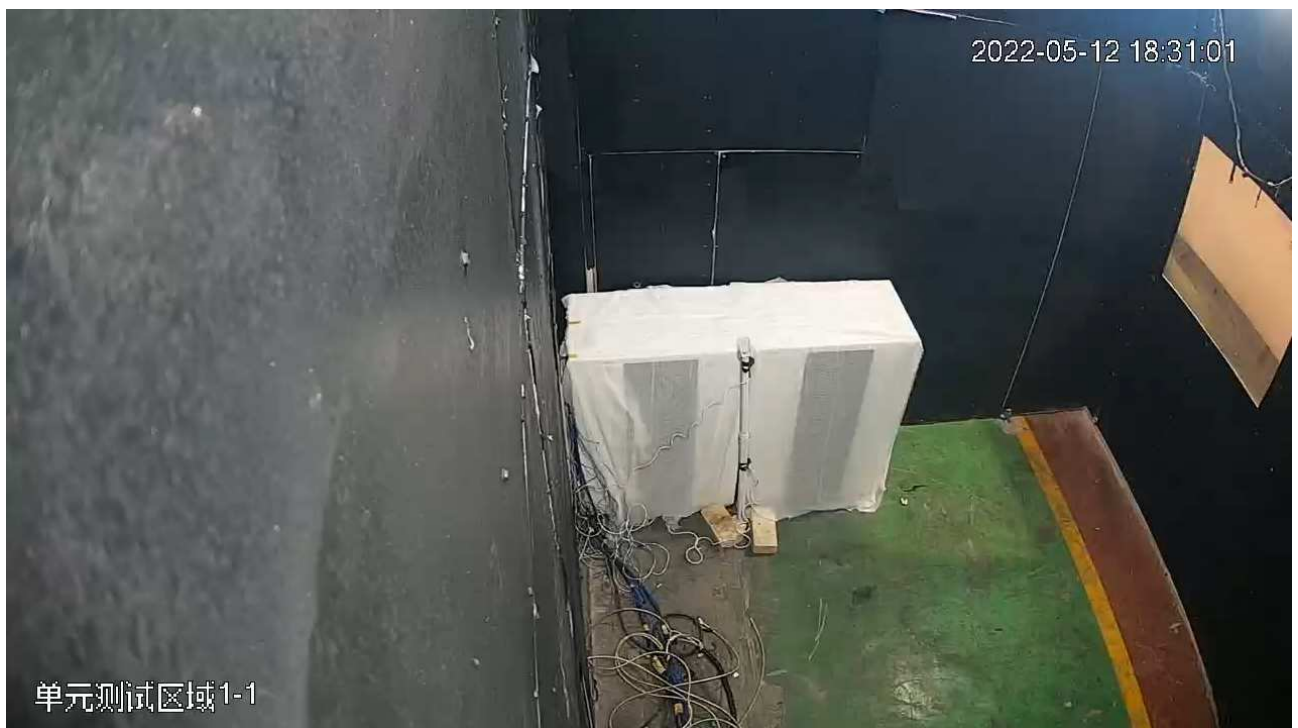

After the test:



## 4 List of Test and Measurement Instruments

No.	Equipment	Model	Rating	Inventory no.	Last Cal. date	
1	Ambient monitor	WSB-2-H1	0-40°C, 10-90%RH	S-055	2022.07.11	
2	Ambient monitor	WSB-2-H1	0-40°C, 10-90%RH	S-050	2022.03.25	
3	Ambient monitor	WSB-2-H1	0-40°C, 10-90%RH	S-044	2022.02.25	
4	Digital multi-meter	FLUKE101	0-600V	S-038	2022.03.14	
5	Tape	1000mm 5000mm	0-1000mm 0-5000mm	S-040 S-042	2022.03.14 2022.03.14	
6	Electronic scale	TCS-500	0-500kg	S-039	2022.02.23	
7	Charge /ischarge equipment	RCDS-100V300A	100V/300A	S-045	2022.02.23	
8	Heating control equipment	DTB4824	0-1000°C	S-046-2	2022.07.11	
9	Data acquisition equipment	ADAM-4117 ADAM-4118 MT4W DTM	0-10V 0-1000°C 0-100V 0-1000°C	S-028-1 S-028-2 S-030-5~8 S-029	2022.02.23 2022.02.23 2022.07.11 2022.02.23	
10	Oxygen consumption calorimeter measurement system	Paramagnetic oxygen analyzer	ABB AO2020	O2: 0-21% CO2:0-10% CO:0-1%	S-062	2022.08.11
		CO and CO2 sensor				
		Light filter	---	25%、50%、75%	S-024-6 S-024-7 S-024-8	2022.03.07
		Gas mass flowmeter	Sevenstar D07-60G	0-8g/s	S-024-9	2022.03.29
		Micro-differential pressure transmitter (3MW)	DP101MD	-100~100Pa	S-024-4	2022.02.23
		Thermopile (3MW)	TT I 20-CAXL-II 6U-10-SPW-M	0-1000°C	S-024-1~3	2022.02.26
		Micro-differential pressure transmitter (2MW)	DP101MD	-100~100Pa	S-028-8	2022.03.25
Thermopile (2MW)	TT I 20-CAXL-II 6U-10-SPW-M	0-1000°C	S-028-5~7	2022.03.25		

**Prüfbericht - Nr.: CN22M2ZQ 001**

Seite 39 von 39  
Page 39 of 39

Test Report No.:

11	Palladium-nickel thin-film solid state sensor	710B	1000ppm-10%	S-023-1	2022..08.11
12	Hydrogen sensor(TCD)	ABB AO2020	0-4%	S-62	2022.08.11
13	Electrochemical hydrogen sensors	H <sub>2</sub> 40000/H <sub>2</sub> 1000	0-4%/0-0.1%	S-023-2~3	2022.08.11
14	Fourier-Transform Infrared Spectrometer	MG6000	0.01ppm-100%	S-019	2022.03.01
15	Flame Ionization Detector	ABB AO2020	0-5000ppm	S-062~10	2022.08.11
16	Heat flux measurement equipment	64-5-20	0-50kW	S-031 S-032 S-033 S-034 S-035 S-036 S-037 S-065	2022.06.10 2022.06.10 2022.06.10 2022.06.10 2022.06.10 2022.06.10 2021.09.15 2021.09.15

**End of Test Report**