

Fortress Power **Avalon**

Installation and Startup Guide



READ ME!

Table of Contents

General overview	3
Battery	3
Inverter	11
Smart Energy Panel (SEP).....	12
Communication interconnection	17
Power interconnection	20
Grid-SEP	23
SEP-Load	24
Inverter-SEP	25
Battery Interconnection	27
Startup sequence	29
Appendix A: AC-coupled PV direct interconnection	32
Appendix B: Generator direct interconnection	33
Appendix C: EV Charger direct interconnection	35
Appendix D: Water-resistant communication connections	36
Appendix E: Additional eSTOP Switch Connection	37
Appendix F: Diagram for longer SEP-Inv. Comms. Cable	38

General overview

An Avalon system consists of at least one inverter, at least one battery (with no fewer than three battery modules) and one smart energy panel. In the remainder of the text, the battery, the inverter, and the smart energy panel (SEP) may be referred to as the “system elements”. The purpose of this guide is to assist the installers with interconnecting the Avalon system elements and connecting the power sources, as well as the loads to the system. This guide also provides the startup sequence for the system, such that after following the steps in this document, the system is ready to be commissioned via the user interface. The guide is created under the assumption that its reader has completed the [Avalon Technical Training \(at training.fortresspower.com\)](https://training.fortresspower.com), is reasonably familiar with the system, and has a conceptual understanding of it.

Use all relevant PPE when performing any work on the Avalon system!

At no point power tools are to be used to assemble the system!

FOLLOW THE SAME SEQUENCE AS IN THE TEXT

Battery

After unboxing the equipment, start by measuring the voltages of the individual battery modules. The voltages must be $\sim 49V$. Ensure that the difference between the highest and the lowest measurements doesn't exceed $0.25V$ and that the terminals aren't damaged.

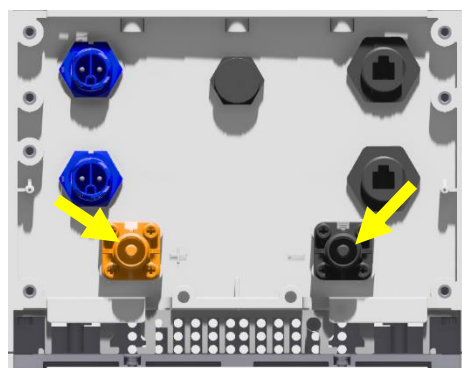

Figure 1: Measuring battery module voltage

Assemble the battery base by mounting the support legs to the base bracket (**Figure 1**). The nuts on the support legs must remain under the base bracket. Note, that the height of the

base may be adjusted by the means of the nut immediately under the base bracket. Use a level while adjusting the battery base legs. When used, ground anchors attach to the base.

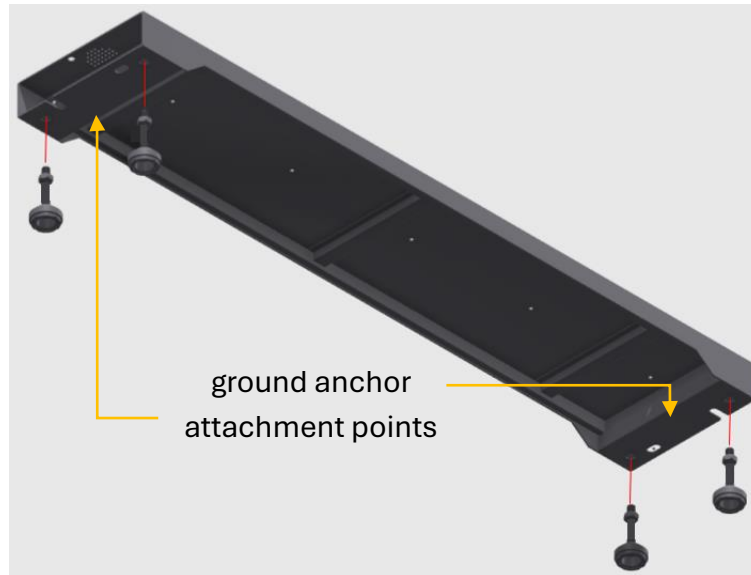

Figure 2: Installing the battery support legs

Once the battery base is assembled, place the first (bottommost) battery module on the battery base. Secure the battery module onto the base using the metal brackets and secure the module onto the wall using the L-shaped metal brackets. The appropriate screws are included in the package. Repeat these steps for all the remaining modules in the stack. Note, when a new module is introduced to the battery stack, it must be secured to the wall and onto the module (or base) under it immediately, before proceeding with the next module. Remember, the last (topmost) module in the stack is always the battery management module.

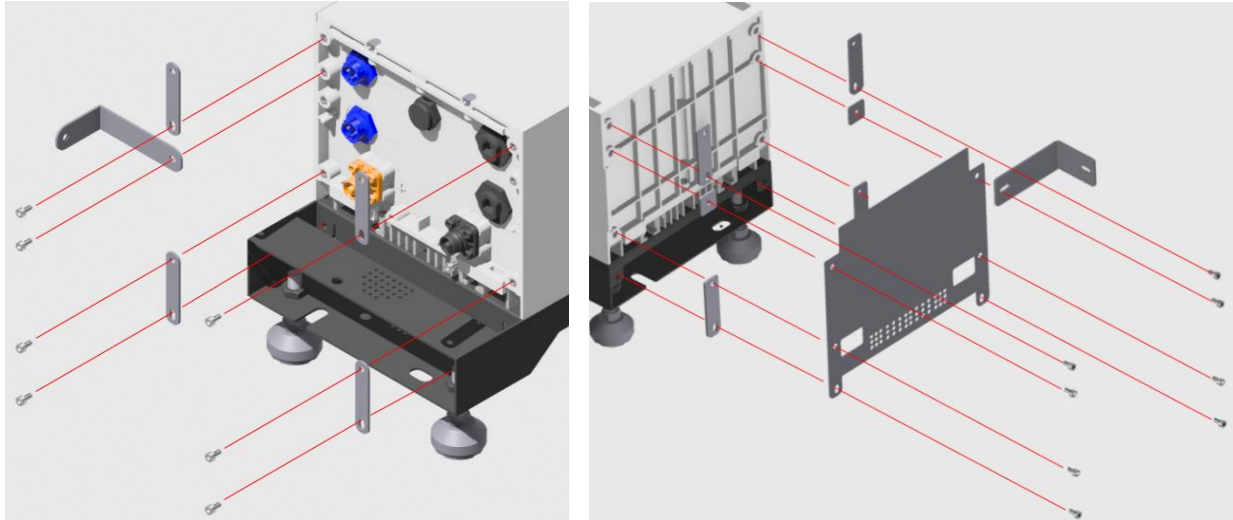

Figure 3: Securing the battery modules using the brackets

After assembling the battery stack, please make sure that the battery management module breaker is in the “OFF” position and that the battery power button is not pressed in. Afterwards, the module-to-module cables and module specific accessories are to be connected.

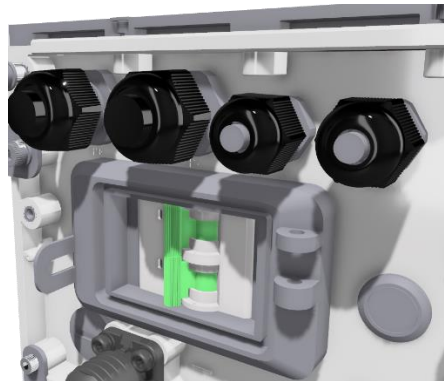

Figure 4: The battery breaker and the battery power button

Use the ground (green/yellow) cables to connect the aluminum heatsinks of the modules to each other. To connect the ground cables to the heatsinks, please use the short plain hex socket cap screws included in the package. Except for the topmost and the bottommost modules, the ground cable lugs will overlap and two of them will be held by a single screw.

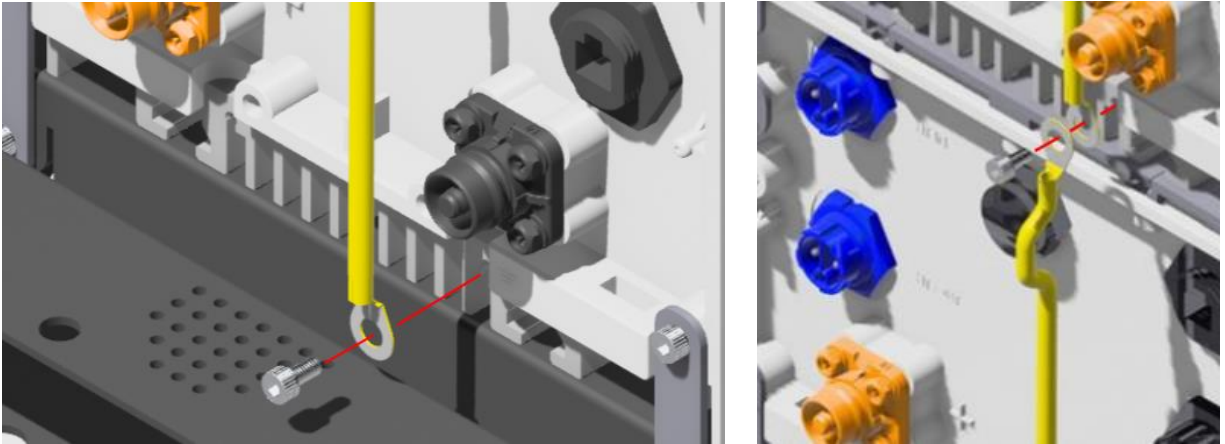

Figure 5: Module to module ground connections

Now that the ground cables are connected, the module-to-module communication cables are next in line. Starting with the battery management module, connect the ethernet (grey) cables to the next module under. The bottommost module will receive the cables from the module above it, whereas the remaining empty port will be occupied by the appropriate plug-connector. Note, the communication (grey/ethernet) cables have water resistant connectors. The ethernet cable must be guided into the ethernet port while the water-resistant shell around it covers/contains the ethernet connector latch. Then, the cable is secured in place by hand tightening the larger diameter nut onto the terminal, followed by hand-tightening the smaller diameter nut onto the larger one (**Appendix E**).

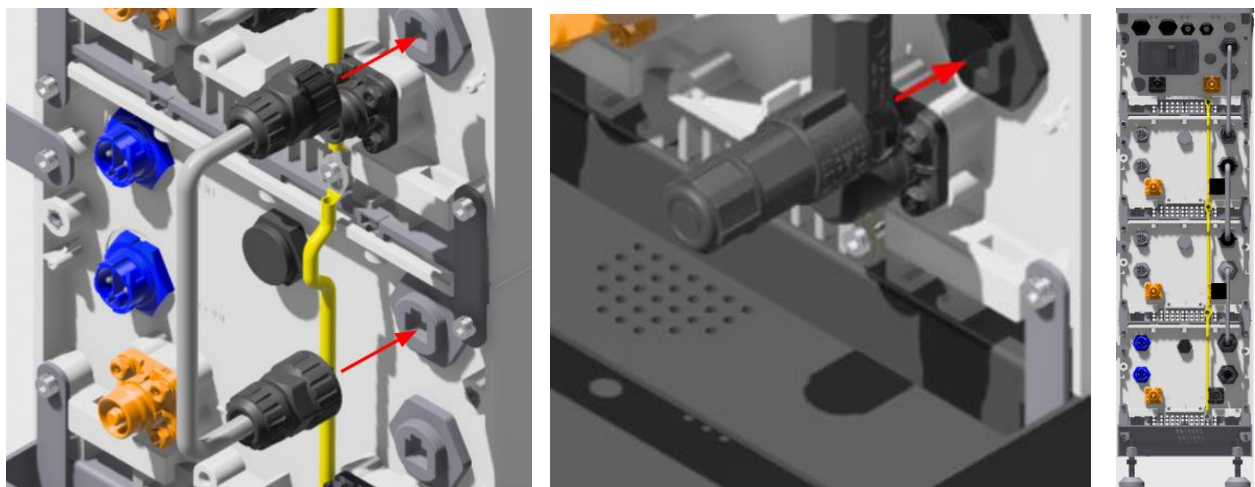

Figure 6: Communication connections

After connecting the module-to-module communication cables, connect the battery modules to each other first via power cables. The battery modules connect to each other in series. The package contains battery module to battery module power cables. These cables have orange and black positive connectors. The colors coincide with the positive and negative terminals of the battery modules. Starting with the bottommost battery module, connect the orange connector to the positive terminal of the bottommost battery module and the black connector of the same cable to the next module above it. Repeat these steps for all battery modules.

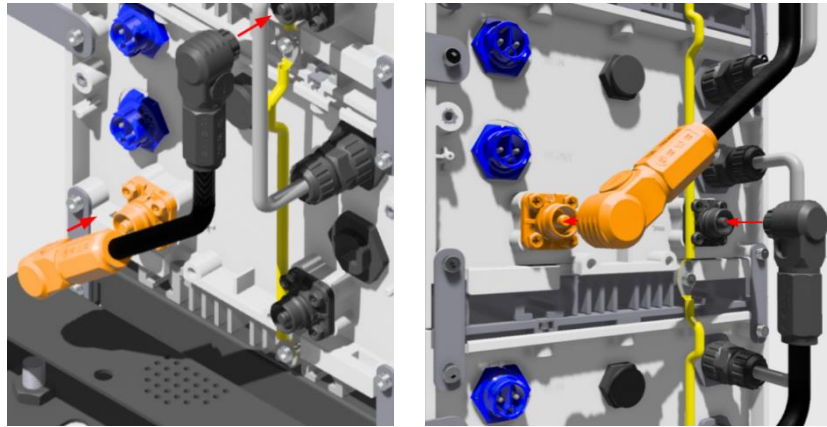

Figure 7: Battery module to battery module power connections

The battery modules are connected in series, but the group of the battery modules, connected to each other in series, connect to the battery management module in parallel. To accomplish such connection, please use the cable with the orange connectors on both ends to connect the positive (orange) terminal of the topmost battery module to the positive (orange) terminal of the battery management module and use the longer cable with the black connectors on both ends to connect the negative (black) terminal of the battery management module to the negative (black) terminal of the bottommost battery module.

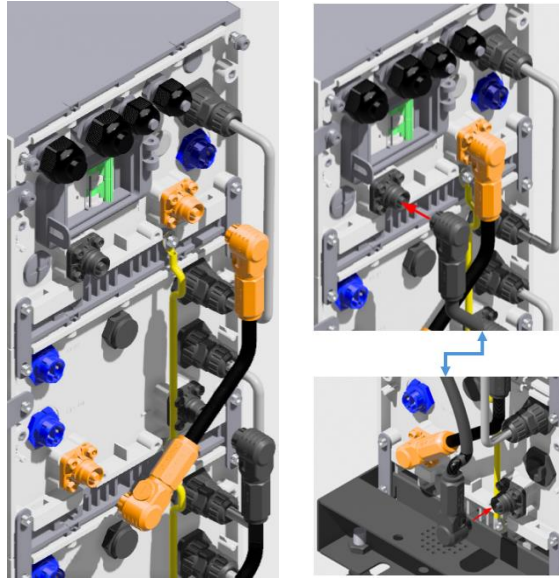

Figure 8: Battery management module to battery modules power connections

Now that the power cables are connected, the heater circuit cables are the only ones left. Starting with the battery management module, connect the heater (blue end) cables to the next module under. The bottommost module will receive the cables from the module above it, whereas the remaining empty port will be occupied by the appropriate (blue) plug-connector. Note, not connecting the battery heating cables will not interrupt the normal operation of the battery, yet in such case the heater will be disabled.

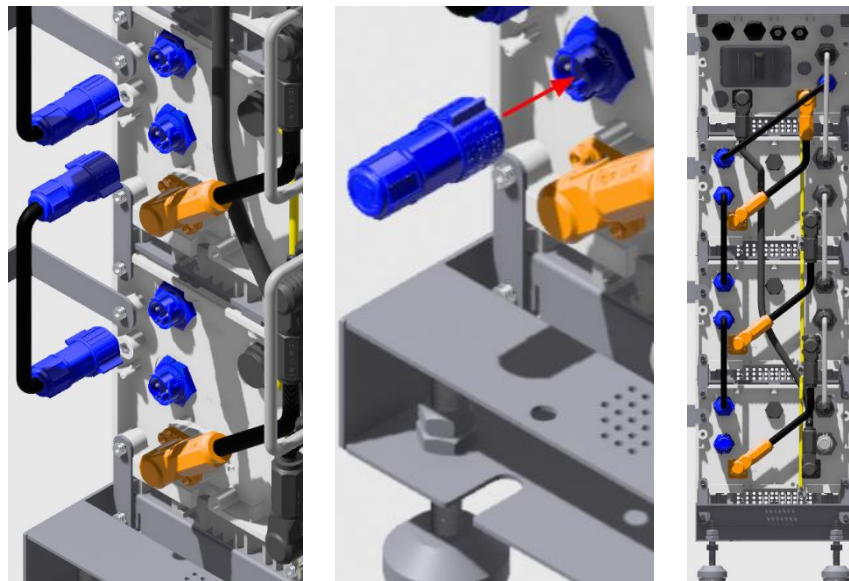

Figure 9: Heater circuit connections

At this stage the battery is functionally assembled. Once the Service compartment cover is removed by removing the screws that secure it in place, the battery is ready to be interconnected with the rest of the system elements, the inverter and the smart energy panel (SEP).

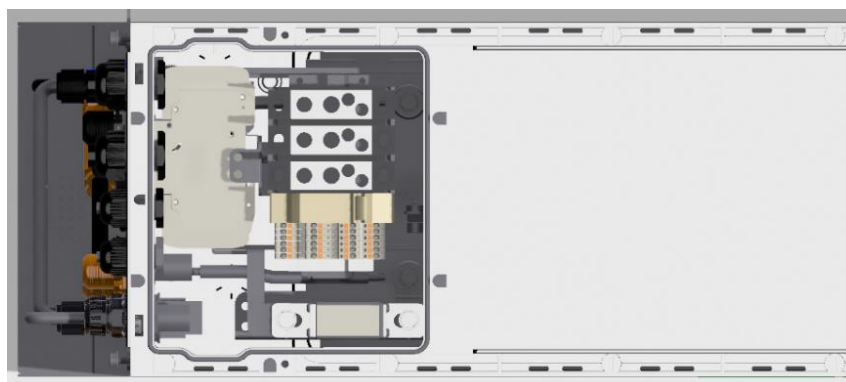

Figure 10: Battery service compartment

The conduit may be connected to either narrow side of the battery management module. Conduit adapters (3/4") are included in the package.

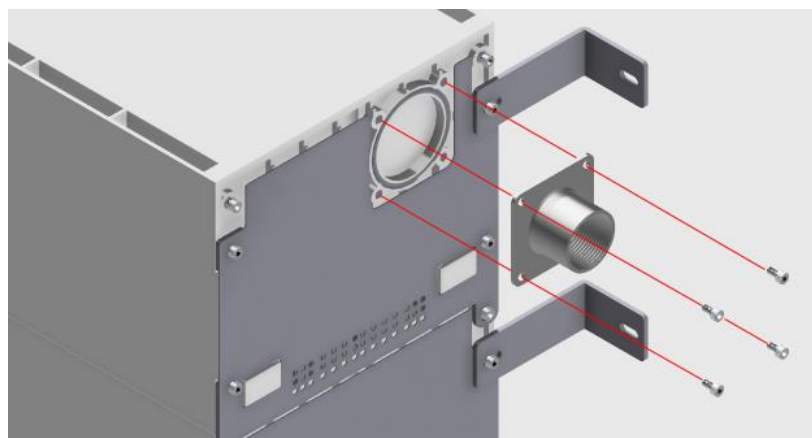

Figure 11: Battery conduit example

If the conduit is to be connected to the opposite end of the battery terminals, the internal (factory installed) conduit of the battery management module is to be used to guide the cables to the terminals.

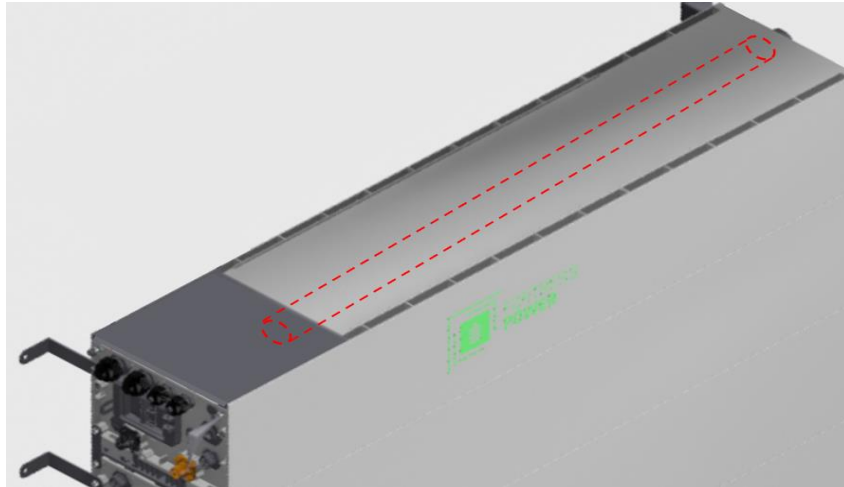

Figure 12: Battery management module internal conduit

The interconnection steps will be covered in this document in the following sections: “Power Interconnection”, and “Communication Interconnection”. Only at the very end of the commissioning process the battery covers may be put in place, thus ensuring that the power button, the breaker, and the service compartment on the top of the battery are still accessible until then.

Inverter

Mount the inverter support bracket onto the wall. Make sure that the arrow cutout is pointing upwards. Mount the inverter on the bracket and secure the unit onto the bracket with one screw on each side

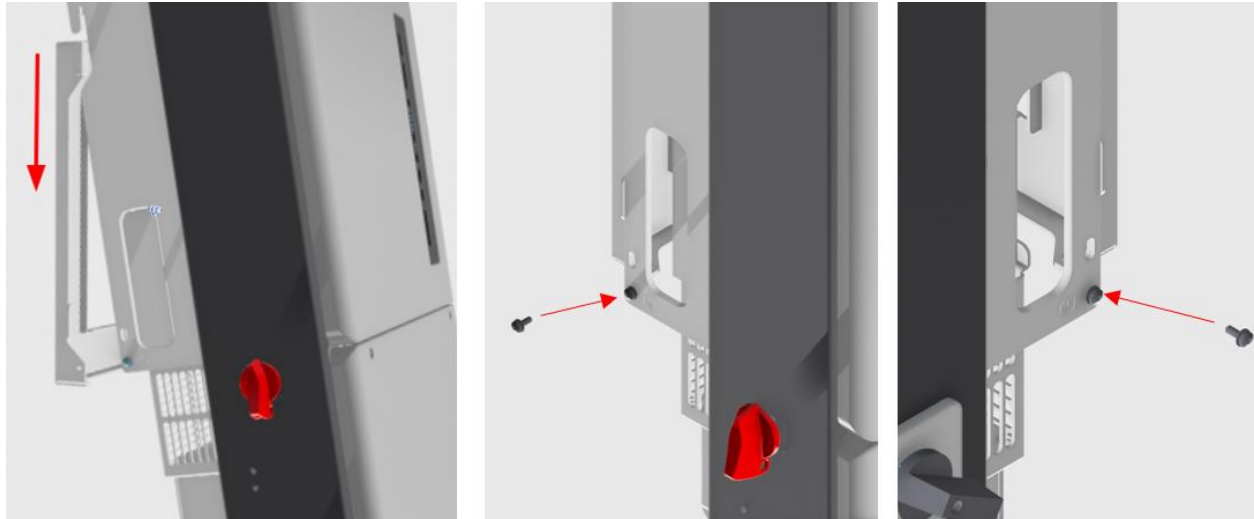

Figure 13: Mounting and securing the inverter

Make sure that the DC Disconnect and the mode selector are both in the off position.

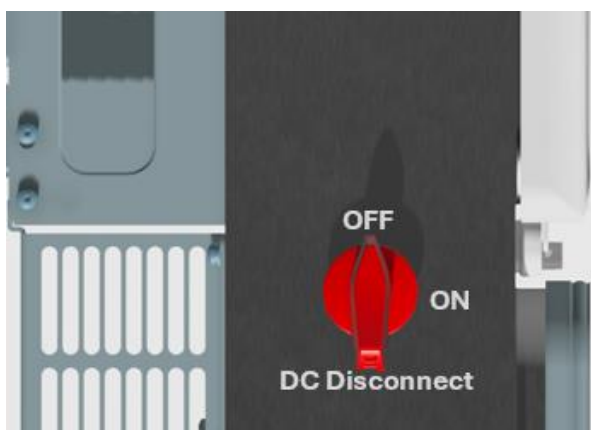

Figure 14a: Inverter DC Disconnect



Figure 14b: Inverter mode selector

Remove the inverter service compartment cover by removing the four torx socket cap screws.

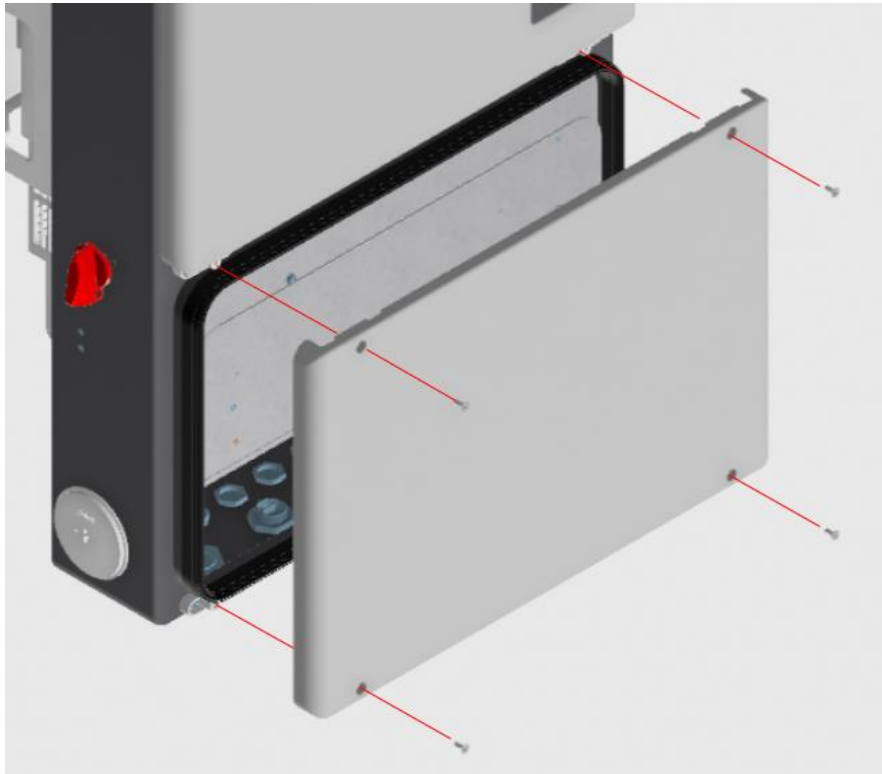

Figure 15: Removing the inverter service compartment cover

At this stage the inverter is ready to be interconnected with the rest of the system elements, the battery and the smart energy panel (SEP). The interconnection steps will be covered in this document in the following sections: “Power Interconnection”, and “Communication Interconnection”.

Smart Energy Panel (SEP)

Mount the SEP support bracket onto the wall. Make sure that the arrow cutout is pointing upwards. Mount the SEP on the bracket and secure it onto it with one screw on each side .



Figure 16: Mounting the SEP

Remove the SEP door by removing the three door hinges and the nut holding the copper braid on the door.

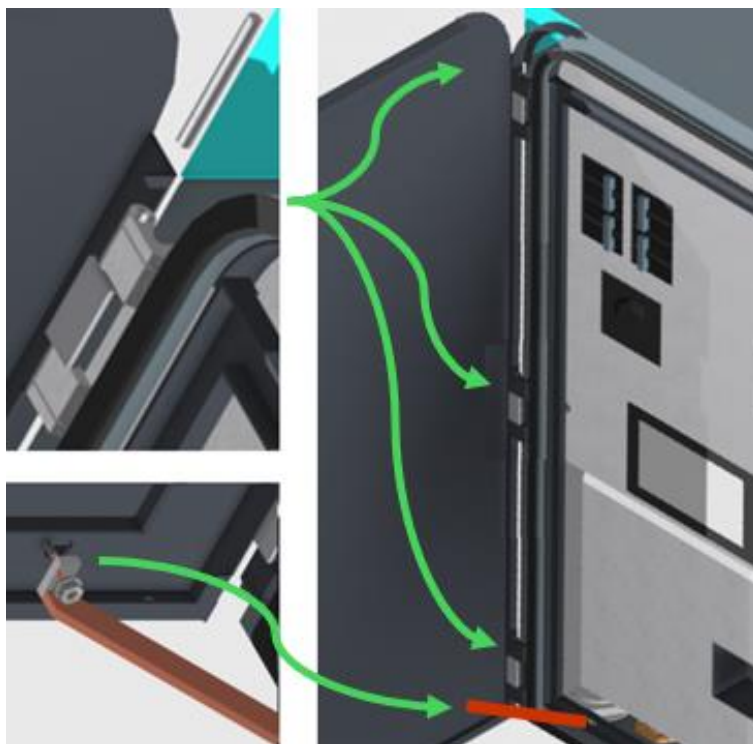

Figure 17: Removing the SEP door

The SEP has two covers, each of which is held in place by four plain hex socket cap screws. Removing the screws allow to remove the covers. It is recommended to remove the top cover first and the bottom cover next (opposite sequence when reassembling the SEP).

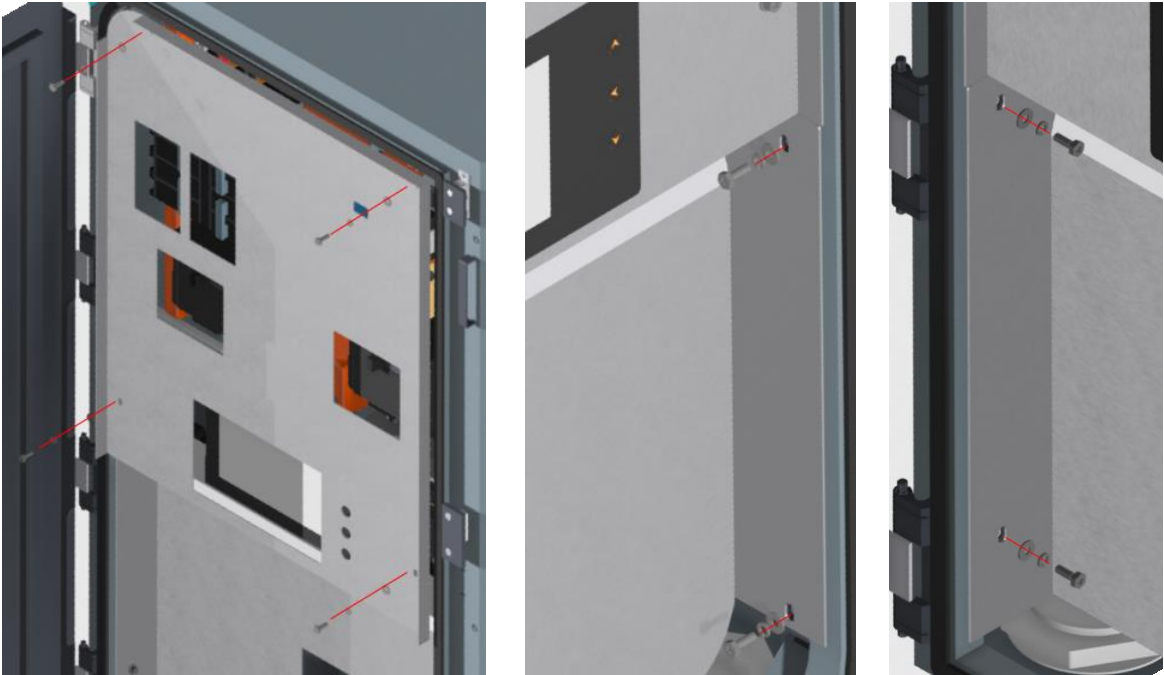

Figure 18: Removing the SEP covers

Make sure that the eSTOP switch is in the OFF position, as well as the grid isolation switch.



Figure 19a: SEP eSTOP switch

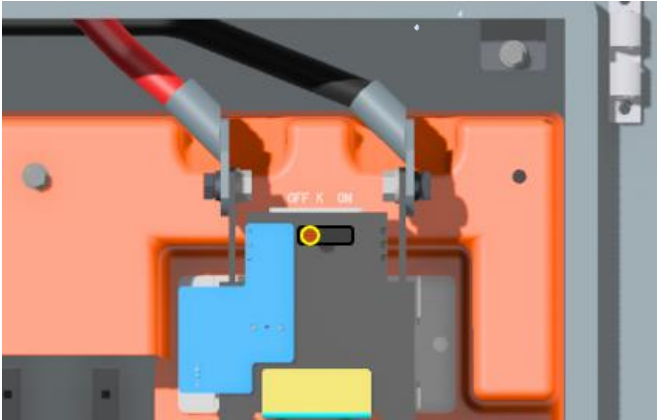
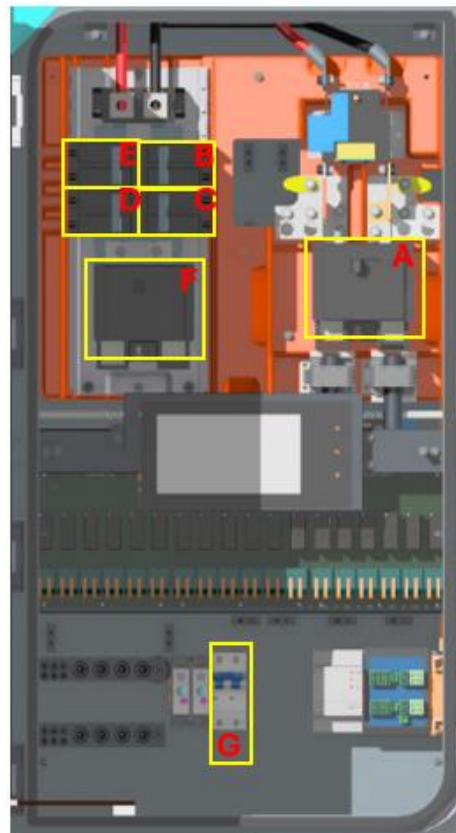

Figure 19b: SEP grid isolation switch

Install the appropriate breakers in the SEP. Two 2-pole breakers are mandatory to be installed in the SEP: one for the “inverter grid” ports (included in the inverter box) and the second one for the “inverter load” ports (NOT included in the package, provided and installed by the customer). Since the “inverter grid” breaker is included in the package, it will be correct to the inverter size. There’s one “inverter grid” breaker included with and used per inverter. Yet, the “inverter load” breaker must be supplied and installed by the customer.

Figure 20:

- A. Grid breaker
- B. Mandatory “inverter load” breaker
- C. EV charger breaker
- D. Generator breaker
- E. AC-coupled PV inverter breaker
- F. Load breaker
- G. Mandatory “inverter grid” breaker



It’s important to have the right breaker in place. Breaker type to be used is Eaton BR 2 series, Siemens Type QP, or equivalent. These breaker types are common, they’re the same type as the ones used in the regular electrical panels. The rest of the breakers that may be installed in the SEP are for the grid input to the SEP, SEP output to the loads, generator input to the SEP, AC-coupled solar input to the SEP, and the SEP output to the generator.

The load and grid breakers are optional. If there is to be a breaker between the utility meter and SEP which can disconnect the SEP from the grid, installing the additional grid breaker in the SEP is arbitrary. The same way, if there is to be a breaker between the SEP and the electrical panel that the Avalon system supports, such that this breaker can disconnect the SEP from the panel, installing the additional load breaker in the SEP is arbitrary. The generator, AC-coupled PV, and the EV charger breakers are installed, if these items are used, and the breaker types may be the same as mentioned above, but their individual current ratings must not exceed 60A. Hence, for example, if there is an EV charger connected to the SEP, only then the need for the EV charger breaker arises and this breaker must be installed in the SEP and its current rating shall not exceed 60A.

AC Source / AC Load	Breaker size
Grid	≤200A
“Inverter load”, one 11.4kW inverter	60A
“Inverter load”, two 11.4kW inverter	125A
“Inverter load”, one 7.6kW inverter	40A
“Inverter load”, two 7.6kW inverter	80A
EV charger	60A
Generator	60A
AC-coupled PV	60A
Load	≤200A
“Inverter grid”	Use all included breakers

Figure 21: SEP breaker sizes

The cables that are internal to the SEP and connect to the breakers are factory installed and routed. Such cables that are not used must remain untouched. **The importance of precisely following the color code/configuration for the “inverter load” and “inverter grid” breakers as outlined in the diagram below (Figure 22) cannot be overstated.**

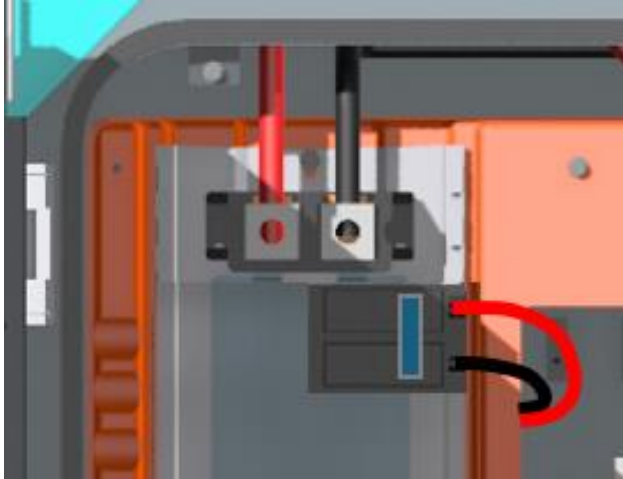

Figure 22a: “Inverter load” breaker

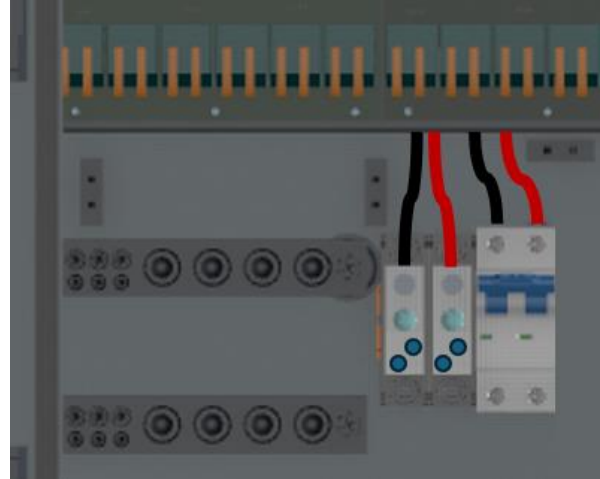

Figure 22b: “Inverter grid” breaker

Once the breakers are installed and the appropriate internal cables of the SEP are wired to them, the SEP is ready to be interconnected with the rest of the system elements and the AC inputs (and outputs). The interconnection steps will be covered in this document in the following sections: “Power Interconnection”, and “Communication Interconnection”.

Communication interconnection

The Avalon system comes with communication cables that may be thought of as wire harnesses. The system elements connect to each other with separate the communication cables such that one standalone communication cable is only responsible for establishing communication between two system elements. For the information on where to connect the communication cables please refer to the following figures in this section. Note, If longer communication cables are needed, up to 100ft, one may use ethernet cable (with its 8 internal cables) for communication interconnections

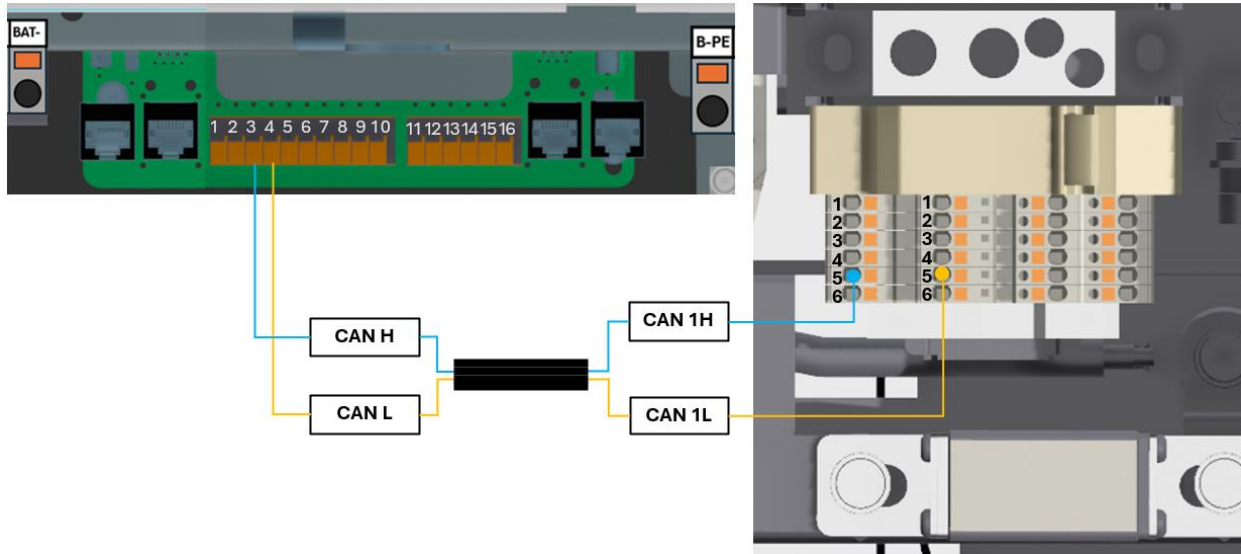

Figure 23: Battery-inverter communication

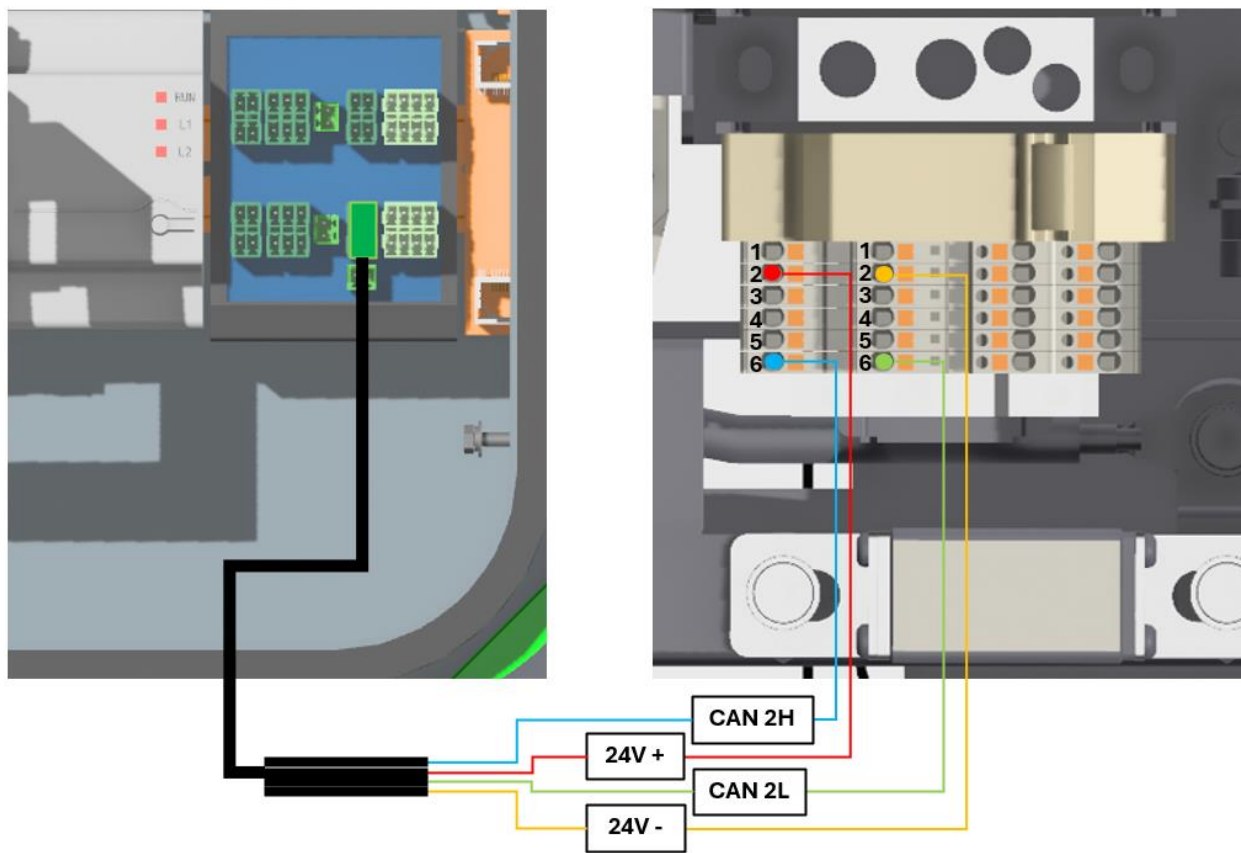

Figure 24: Battery-SEP communication

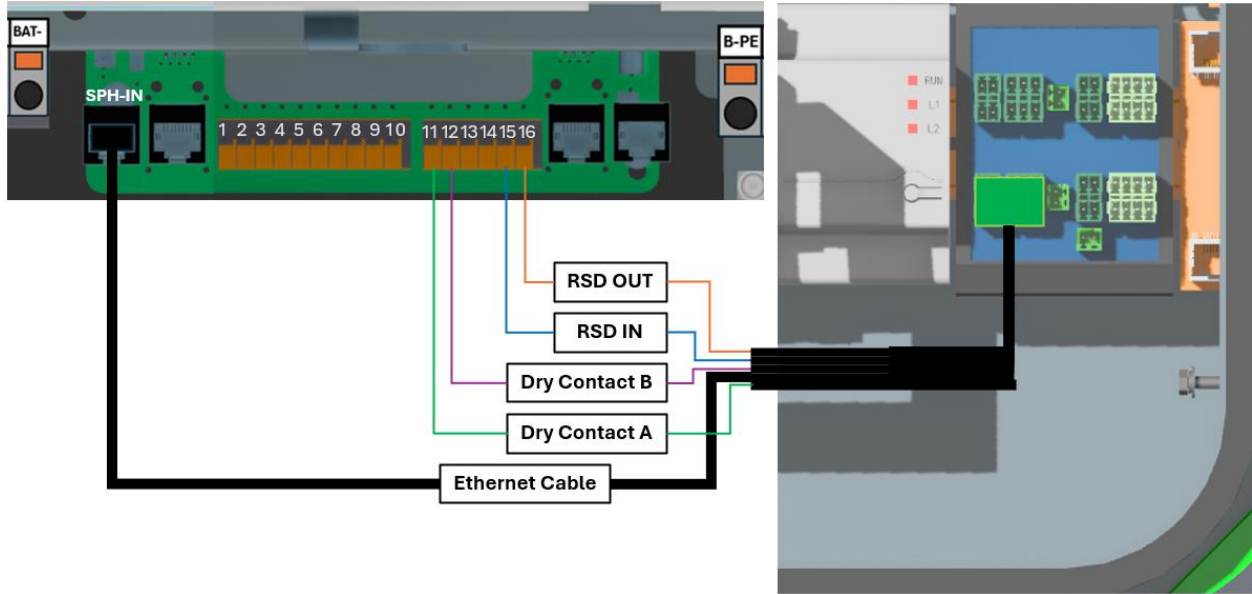

Figure 25: Inverter-SEP communication

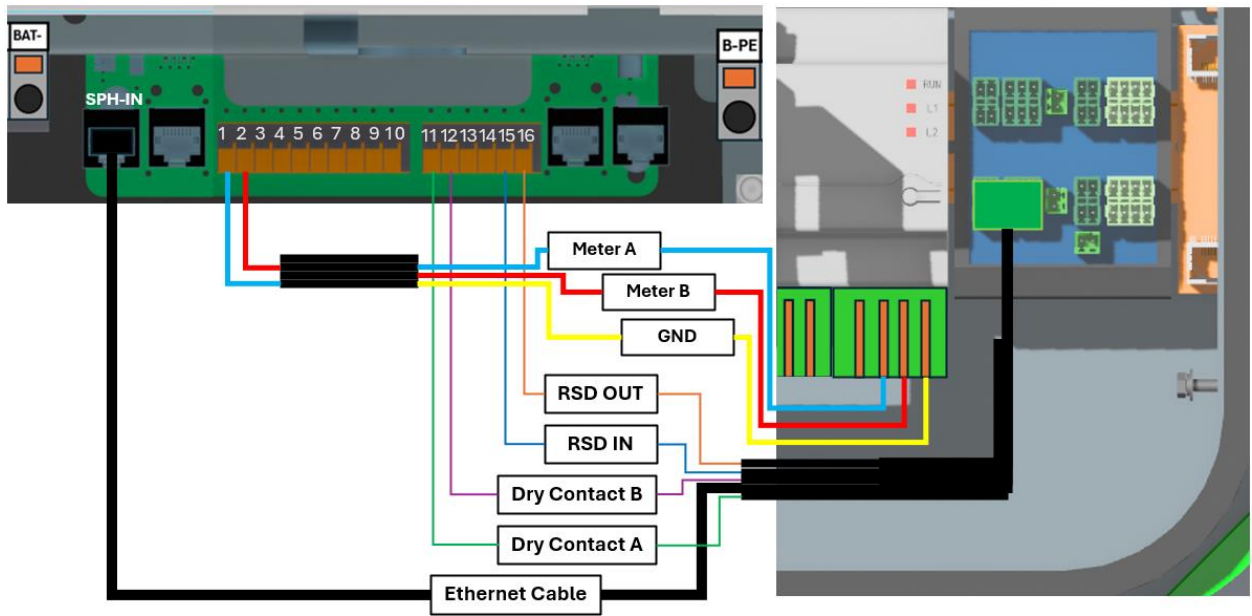

Figure 26: Inverter-Meter communication

For information on communication interconnection when multiple batteries are used, please refer to **Appendix A**. For information on communication interconnection when multiple inverters are used, please refer to **Appendix B**.

Power interconnection

Prior to proceeding with the interconnection of the system elements and connecting the system to the grid, please reconfirm and ensure that the battery and its breaker are off, as well as the inverter switch and the inverter breaker. Please also reconfirm and ensure that the breakers in the SEP and the SEP's grid isolation switch are in the off position and that the cables establishing the connection between the grid and the SEP carry no voltage.

One may see the neutral to ground bond included with the SEP. If the neutral and ground are bonded in the panel that the Avalon system is to support, please remove the existing (old) bond and install the new bond in the SEP. Otherwise, please retain the existing bond and discard the one that came with the SEP.

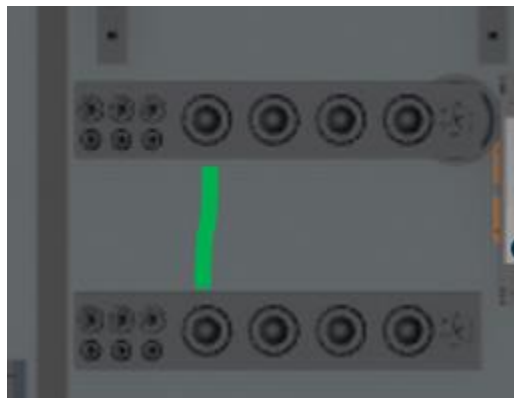

Figure 27: Neutral to Ground bond in the SEP

For information on power cable connections when multiple batteries are used, please refer to **Appendix A**. For information on power cable connections when multiple inverters are used, please refer to **Appendix B**.

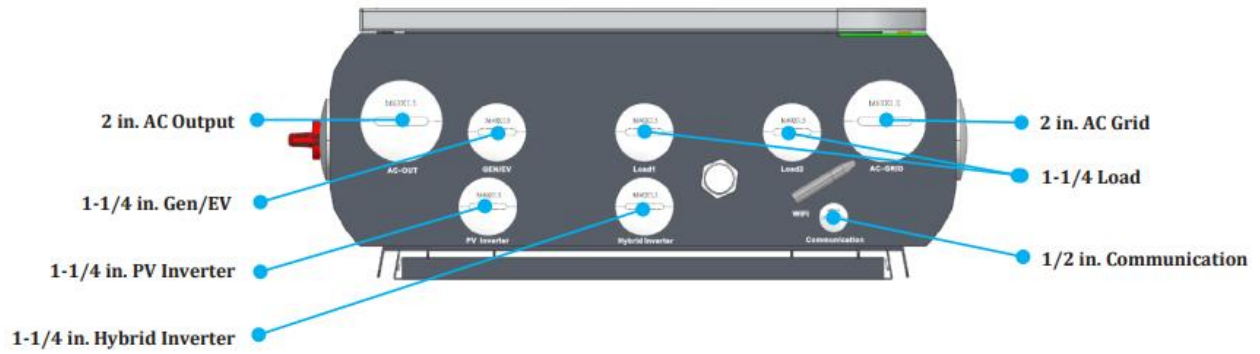

Figure 28: SEP conduit cutout sizes

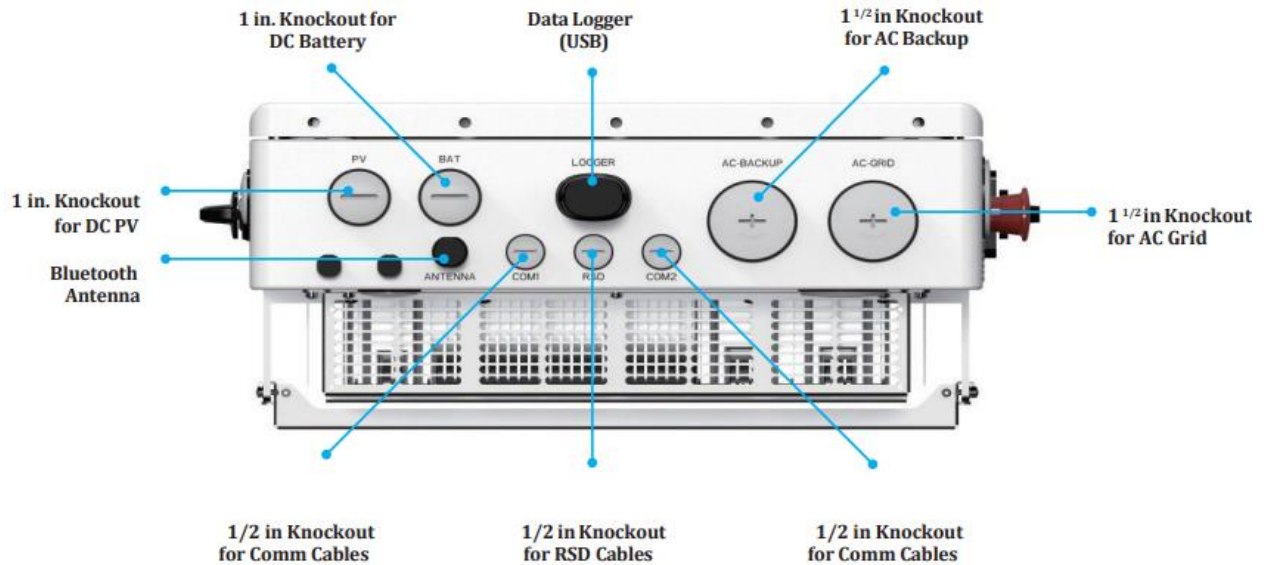

Figure 29: Inverter conduit cutout sizes

Wire Name	Purpose	Making Connection	Wire Gauge Guide
PV Cables (Customer supply)	PV DC connection to the inverter	From the PV array to the DC+ and DC- terminals in the inverter	6AWG
Battery Cables (Customer supply)	Battery DC connection to the inverter	From the battery (+) and (-) terminals to the inverter BAT+ and BAT- terminals	4 or 6AWG
AC Grid Cables (Customer supply)	Inverter AC connection to the SEP	From the OCPD in the SEP to the AC-GRID L1 and L2 terminals	6AWG
AC Backup Cables (Customer supply)	Inverter AC connection to the backup subpanel	From the backup subpanel OCPD to the inverter AC-BACKUP L1 and L2 terminals	6AWG
Ground Cables (Customer supply)	Grounding conductors for the system	From the SEP ground bar to the ground bar inside the inverter wire box	6AWG
Meter RS485 Cable (Included in BMS package)	Communication between inverter & meter	From meter to terminal Meter_A and Meter_B. For more details, refer to Battery installation guide.	22-16AWG

Figure 30: General wire size guide

IMPORTANT!

Precisely follow the color codes shown in the figures

Grid-SEP

Connect the grid L1 and L2 cables to the SEP busbars or to the grid breaker in the SEP if you have installed one. Connect the grid neutral to the neutral busbar in the SEP.

The L1 and L2 cables must go through the built in CTs, which may be opened to make the job easier. The CTs are removable and half-core, allowing the user to open it for ease of running a cable through it and then close it back. When the Avalon is to provide a partial home backup, the CTs will be connected to the SEP, but will be mounted around the grid input cables in the main service panel. Note, the grid enters the SEP from the right side in this case, but remember that the SEP has other “entrances” as well.

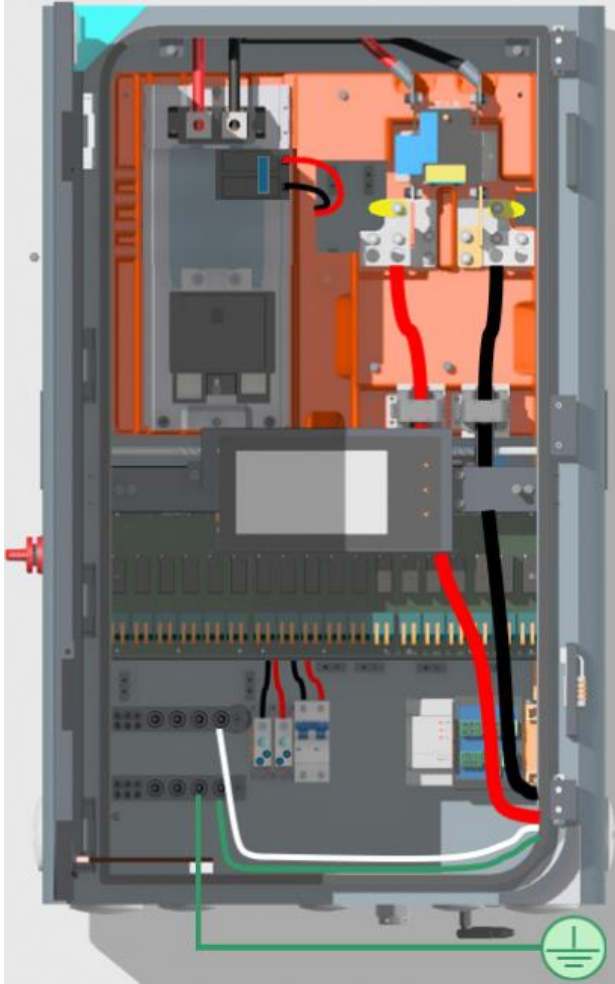

Figure 31a:
Grid-SEP connection

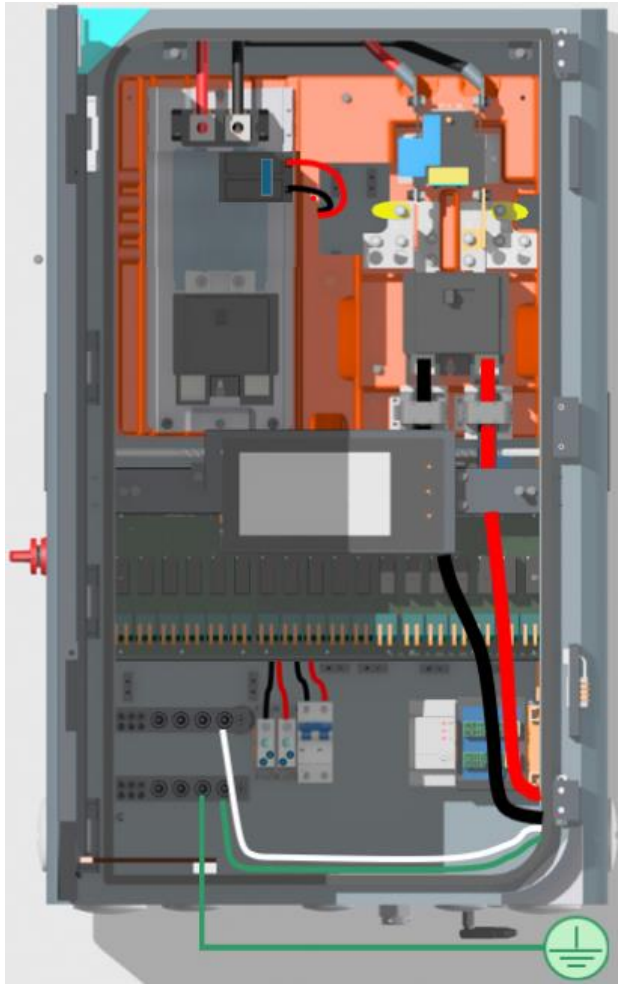

Figure 31b:
Grid-SEP connection with the breaker

SEP-Load

Connect the backed up electrical panel's L1 and L2 cables to the SEP busbars or to the load breaker in the SEP if you have installed one. Connect the electrical panel neutral to the neutral busbar in the SEP.

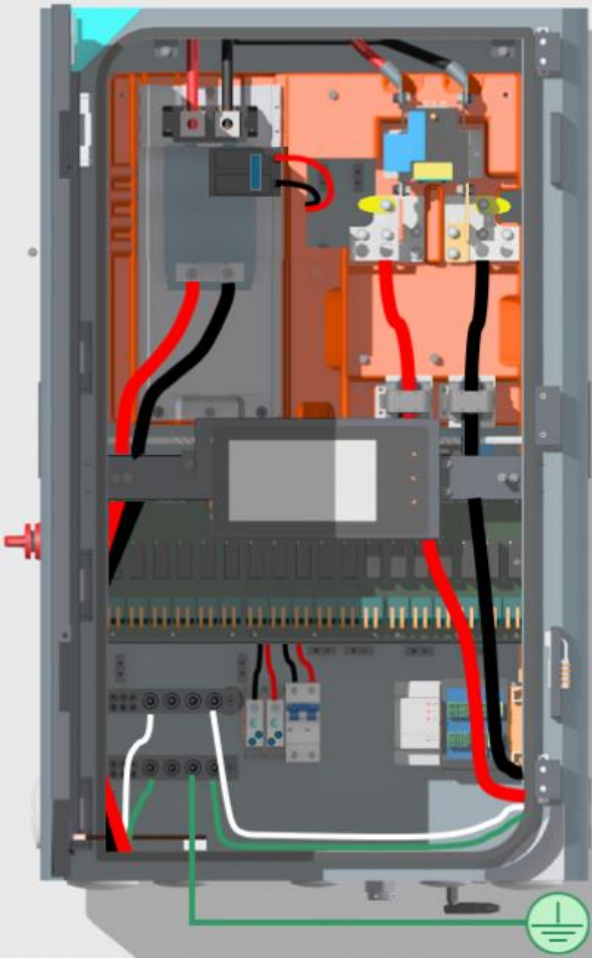

Figure 32a:

Grid to electrical panel connection

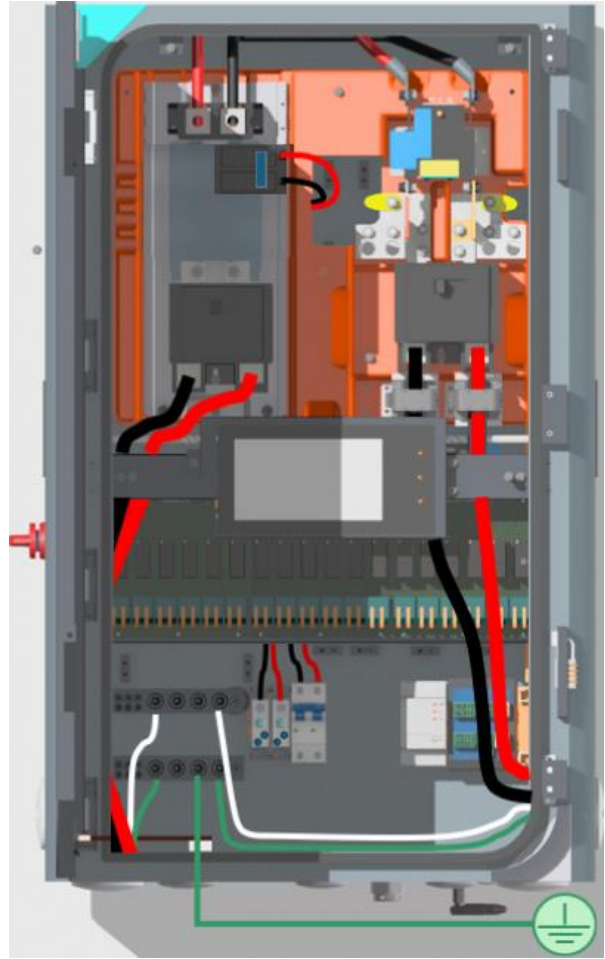

Figure 32b:

Grid to electrical panel connection with breaker

Inverter-SEP

Connect the “inverter load” ground (B-PE) to the ground bar of the inverter and then connect the inverter ground bar to the ground bar of the SEP (**Figure 33**).

Connect the “inverter grid” L1 (G-L1) and L2 (G-L2) to the breakers that came with the Avalon package and that you’ve already installed in the SEP. Connect the “inverter grid” neutral (G-N) to the neutral busbar in the SEP. Please make sure to precisely follow the color code as shown in the figures below.

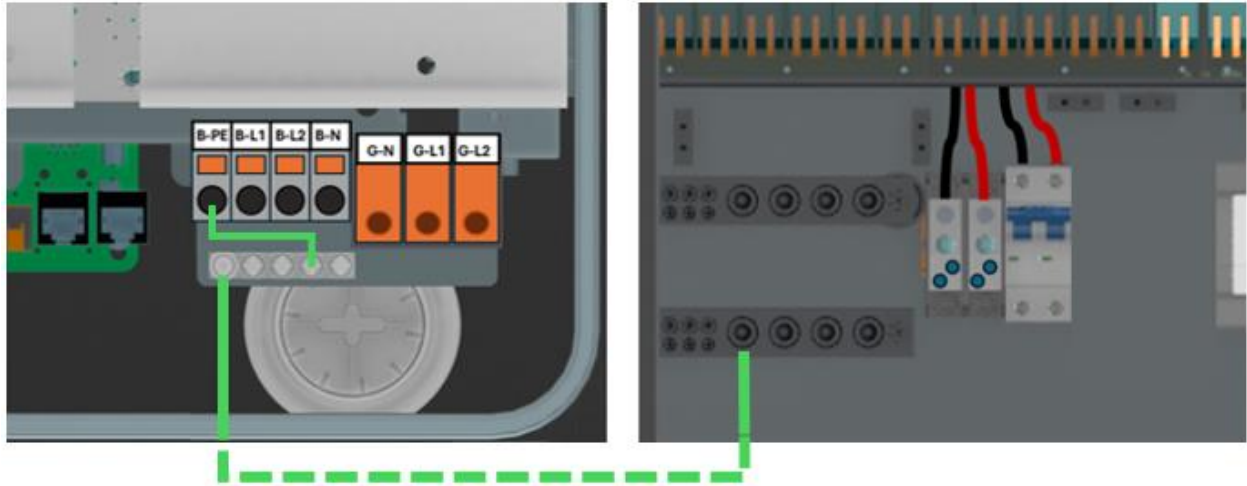

Figure 33: Inverter ground to SEP ground

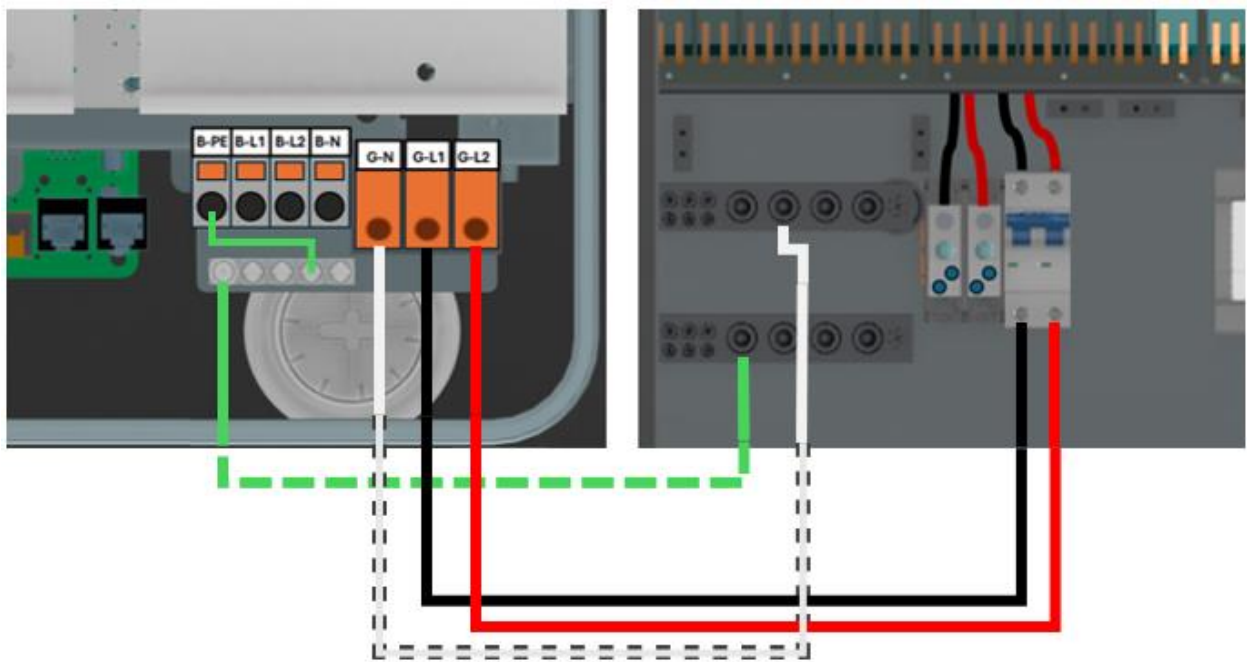

Figure 34: "Inverter grid" to SEP L1, L2, and N

Connect the "inverter load" L1 (B-L1) and L2 (B-L2) to the combining busbars that came built-in with the SEP. Connect the "inverter load" neutral (B-N) to the neutral busbar in the SEP. Notice, the "inverter load" ground (B-PE) doesn't connect to anything. Please make sure to precisely follow the color code as shown in the figure below.

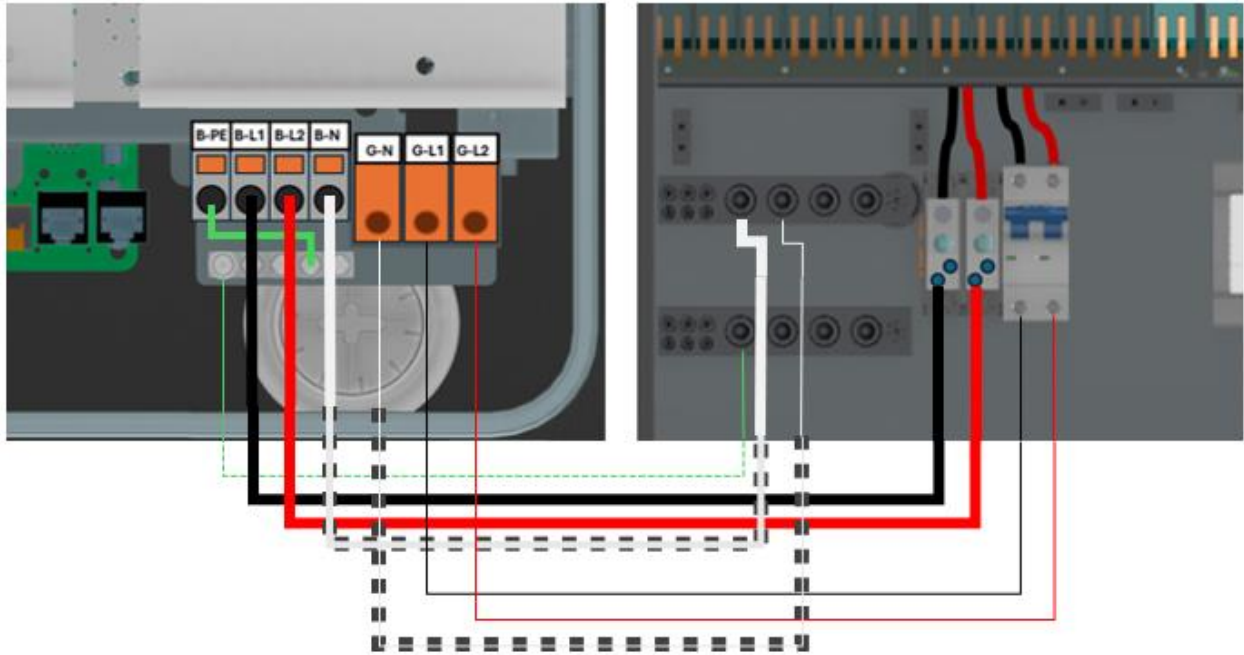

Figure 35a: “Inverter load” to SEP L1, L2, and N

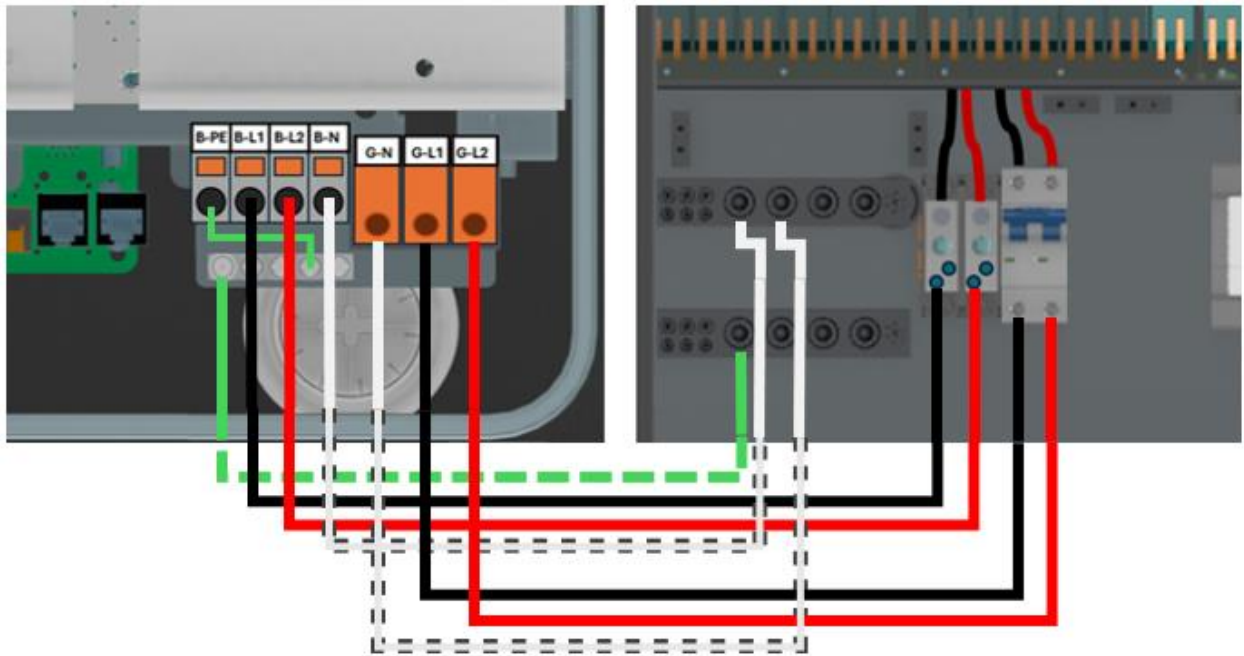

Figure 35b: Inverter and SEP interconnected

Battery Interconnection

Connect the positive and negative terminals of the battery to the inverter’s positive (BAT+) and negative (BAT-) ports, respectively. Note, the battery ground terminal connects to the ground bar in the SEP.

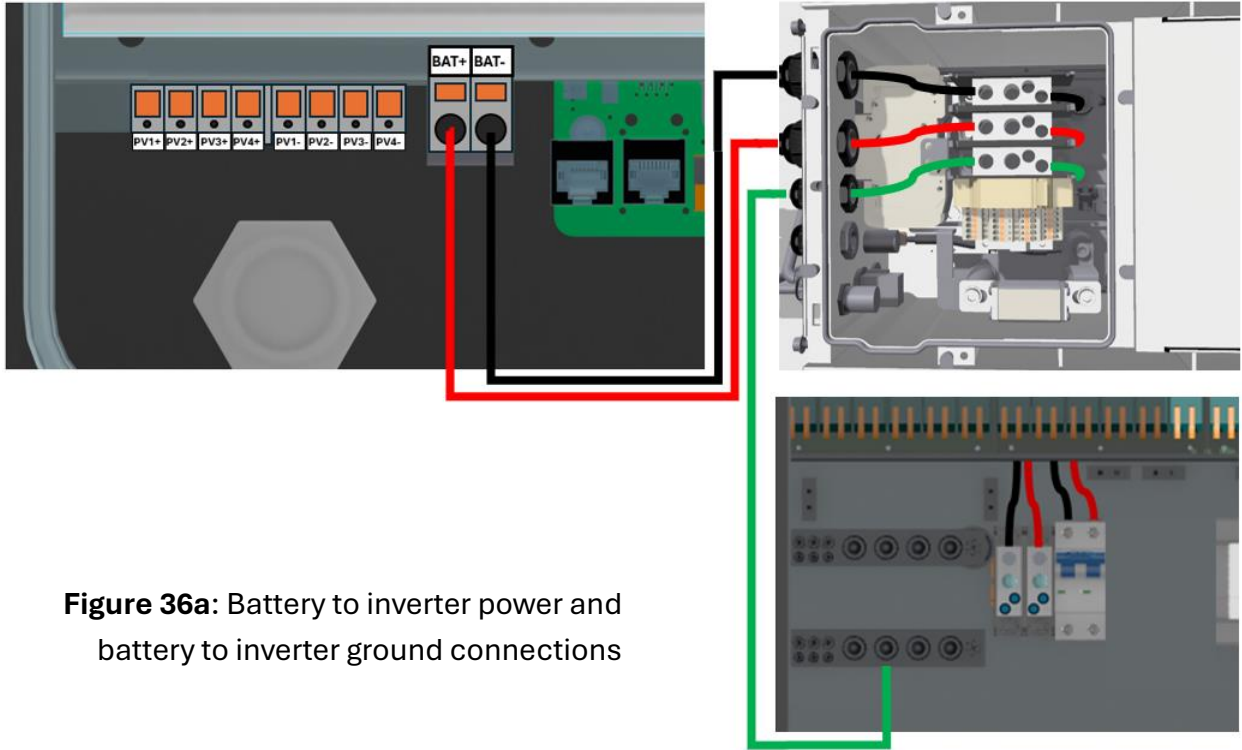

Figure 36a: Battery to inverter power and battery to inverter ground connections

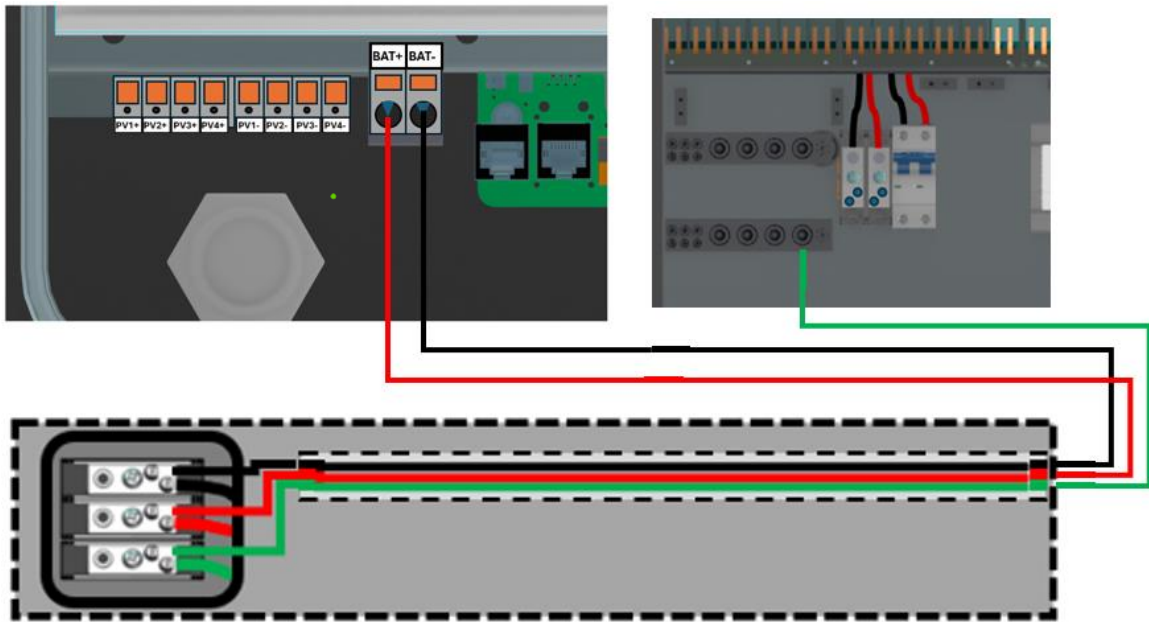

Figure 36b: Alternative battery to inverter power and battery to inverter ground connections

Startup sequence

Prior to turning any piece of equipment on, please make sure that the “inverter load” and “inverter grid” phasing is correct. Please put in the ON position the “inverter grid” breaker, “inverter load” breaker, and the grid isolation switch (**Figure 19b, Figure 20**). **KEEP THE GRID BREAKER IN THE OFF POSITION. AT THIS POINT, THE GRID MUST NOT BE ABLE TO PROVIDE VOLTAGE TO THE SEP (Figure 20).** Test the continuity as shown in **Figure 37**.

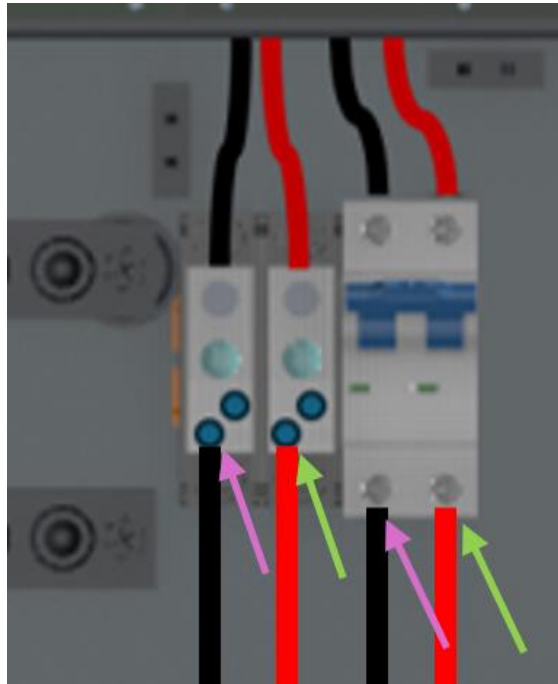

Figure 37: Testing continuity between “inverter load” L1 (L2) and “inverter grid” L1(L2)

If the continuity is present, put the “inverter grid” breaker, “inverter load” breaker, and the grid isolation switch back in the OFF position. If the continuity isn’t present, swap L1 and L2 positions on the “inverter load breaker (**Figure 20, B**) and test the continuity again. If the continuity is still not detected, please contact Fortress Power tech-support, if the change allowed to establish the continuity, then continue to the next step. Either way, after performing the continuity test, please put the “inverter grid” breaker, “inverter load” breaker, and the grid isolation switch back in the OFF position (**Figure 20**). Once the continuity is established, and the breakers, as well as the switch are put back in the OFF position, please follow the instructions below, in the sequence given below, to start up the system.

- Put the battery breaker in the ON position. Press the battery power button (no need to hold it pressed in, it latches automatically). In approximately 3 seconds, the battery status light will turn on green.
- If multiple battery units are used, prior to using the power button on either of them, put breakers of all batteries in the ON position. Then, first turn on the battery unit which communicates with the SEP and immediately when its green light comes on, press the power button on the next battery. At this stage, the SEP screen must be on and about a minute after using the battery power button, the inverter will turn on
- If multiple inverters are used, follow the instructions above and then proceed to the next battery-inverter group, where the first battery to be turned on is going to be the one which connects to its inverter. If the system has only one battery per inverter, this first battery happens to be the last one as well. Yet, if there are two batteries per inverter, immediately when the green light on the first batter comes on, press in the power on the next battery. Just like with the first battery-inverter group, about a minute later, the inverter in this group will turn on.
- After the inverters are on and have completed the precheck sequence (which usually takes 2 minutes), put the “inverter load” and “inverter grid breakers” in the on position.
- At this stage, the grid voltage is introduced to the system by putting the main grid breaker in the on position.
- With the steps above covered, put the load breaker in the ON position as well.
- The DC-Disconnect is now to be put in the on position.
- Afterwards, please put the eSTOP switch on the SEP in the “Run” position, and on the screen of the SEP, tap commissioning. Then, please use the Fortress – Avalon Installer app on your iOS or Android mobile device to commission the system. The app contains instructions and is quite self-explanatory. If the mobile device is unavailable, you may continue using the Avalon SEP screen, yet configurability that the screen provides is very basic and significantly limited compared to the mobile app.
- If applicable, after the Avalon system is commissioned, the AC-coupled PV breaker is to be put in the ON position, as well as the generator and the EV charger breakers.
- Once confirmed that the system is commissioned and operational, all the appropriate plastic and metal covers may be put on the equipment. When putting on the battery covers on, please put on the battery rubber top covers on first and only then put on the plastic covers, starting with the bottommost battery module and finishing with the battery management module on the top (**Figure 38**).
- Now the system is ready to be commissioned via [Avalon Installer app](#).

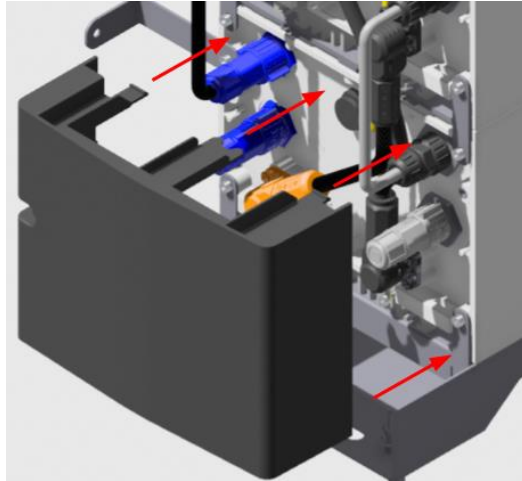

Figure 38a: Installing the battery covers

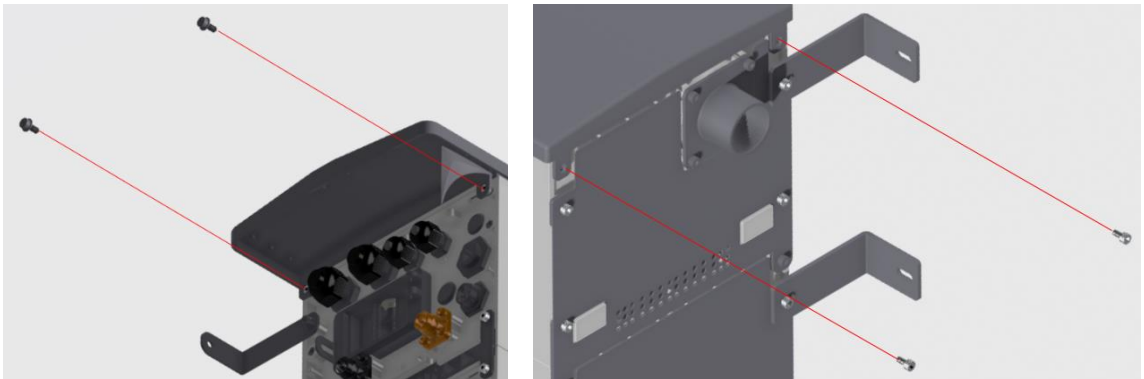
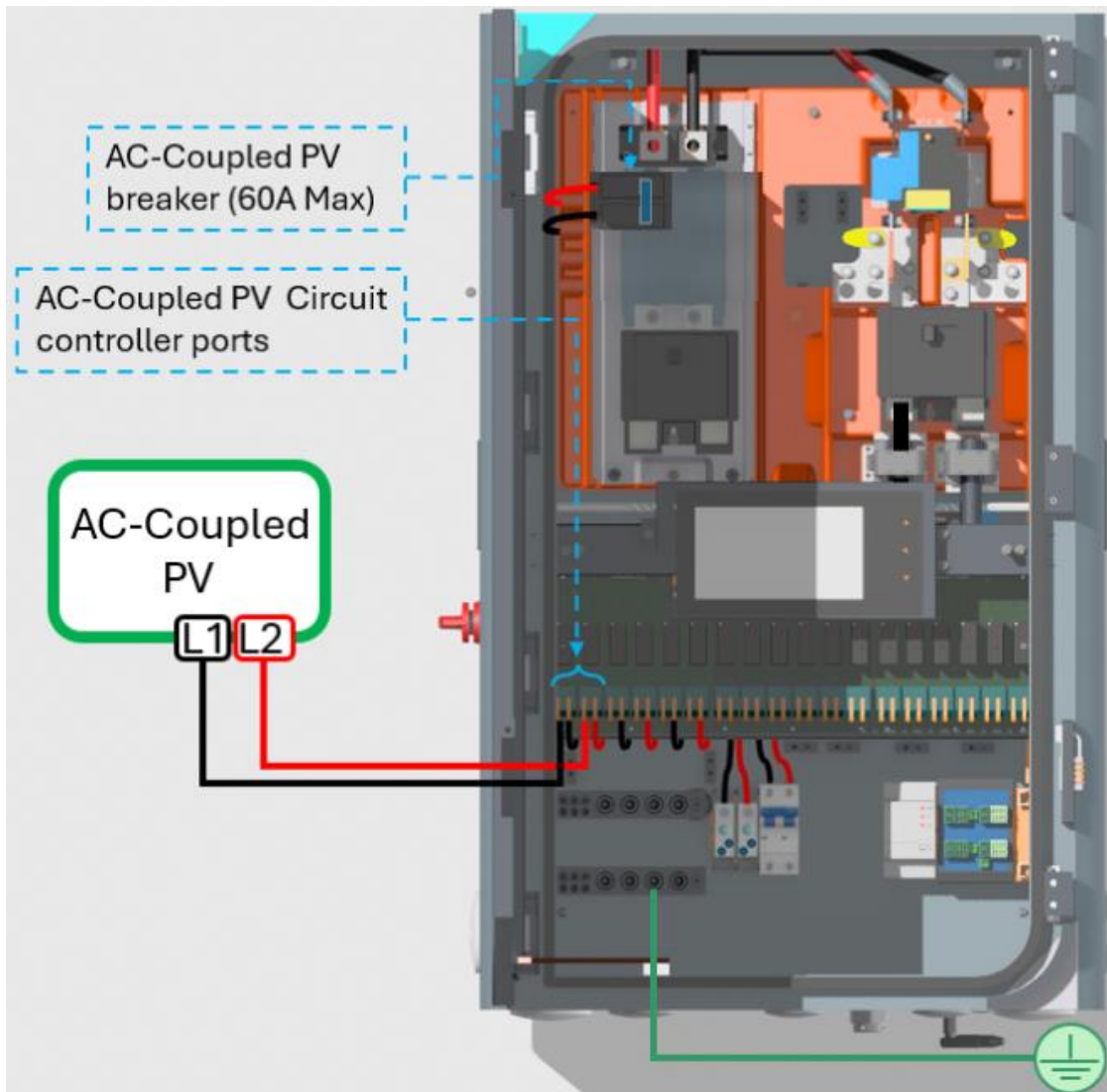

Figure 38a: Installing the battery top cover

Appendix A: AC-coupled PV direct interconnection

AC coupled PV may be connected to the SEP directly. AC coupled PV that is connected directly to the SEP must not be able to deliver over 12kW of power. To achieve such interconnection, connect the L1 and L2 to the AC coupled circuit control contactor ports. When applicable, AC coupled PV ground connects to the ground busbar of the SEP.

After the AC coupled PV power cables are connected to the appropriate ports, install a breaker (Eaton BR 2 series or equivalent, 60A max) on the main busbar in the designated area. When the AC coupled PV delivers it will have to flow through the breaker to the Avalon system and the loads. If the breaker is in the off position, the power flow is prevented. The cable that connects the breaker to the contactor is installed in the SEP from the factory and is connected to the contactor. All that is remaining is to connect the other end of the cable to the breaker.



Appendix B: Generator direct interconnection

Generator charger is to be connected to the SEP directly. Power demand imposed on the generator by the battery bank, loads, or a combination of the two, must not exceed 12kW. The latter remains true for a generator of any size and rating.

To interconnect a generator to an SEP panel, connect the L1 and L2 of the generator to the generator circuit control contactor ports. When applicable, generator ground and neutral connects to the ground and neutral busbars of the SEP, respectively.

After the generator power cables are connected to the appropriate ports, install a breaker (Eaton BR 2 series or equivalent, 60A max) on the main busbar in the designated area. When the generator delivers power, it will have to flow through the breaker to the Avalon system and the loads. If the breaker is in the off position, the power flow is prevented. The cable that connects the breaker to the contactor is installed in the SEP from the factory and is connected to the contactor. All that is remaining is to connect the other end of the cable to the breaker.

Generator 2-wire start cables connect to the two dedicated ports on the SEP communication ports.

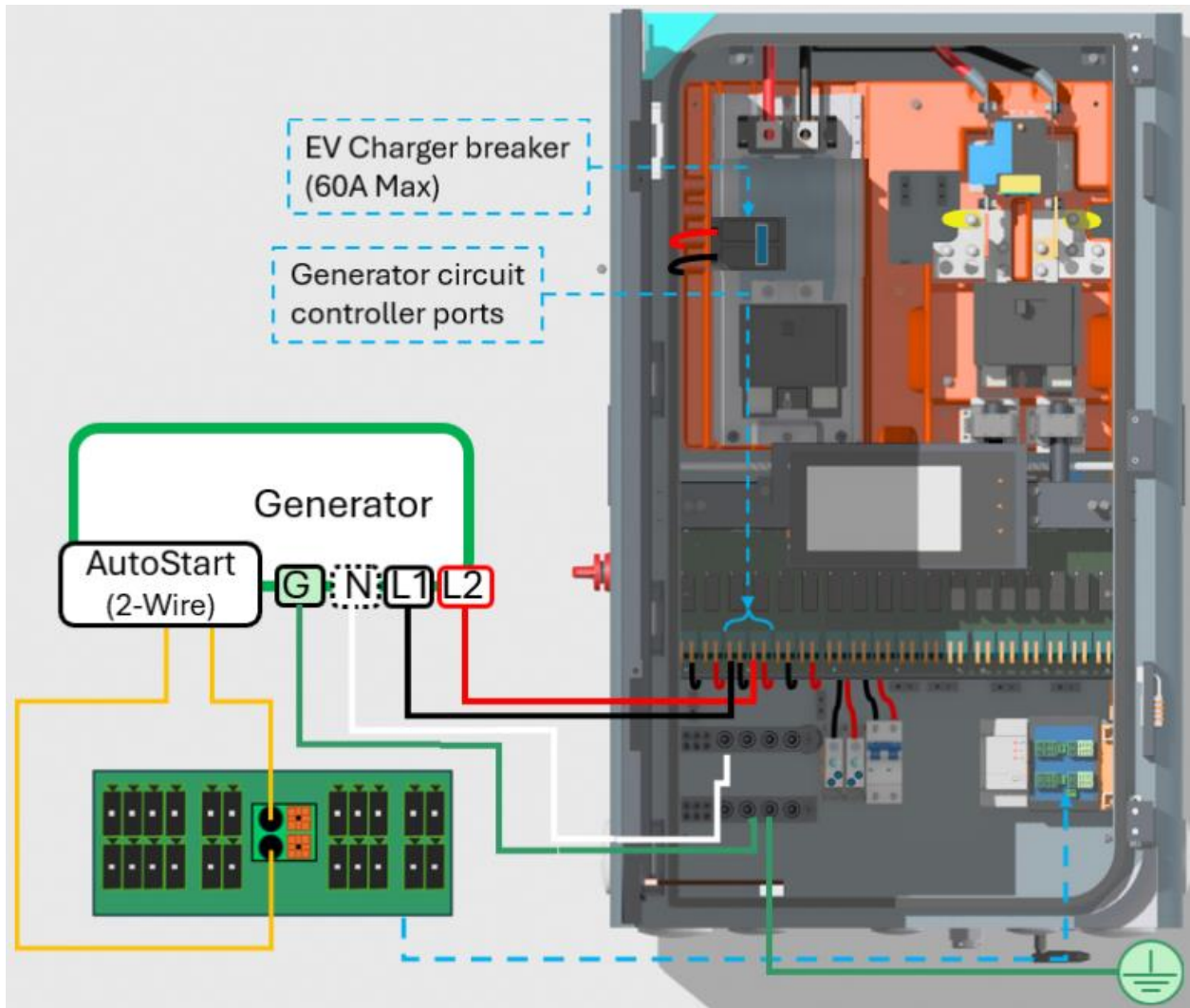

Appendix C: EV Charger direct interconnection

EV charger is to be connected to the SEP directly. To achieve such interconnection, connect the L1 and L2 of the EV charger to the dedicated load shedding ports. If applicable, EV charger ground connects to the ground busbar of the SEP and the EV charger neutral connects to the neutral busbar of the SEP .

After the EV charger power cables are connected to the appropriate ports, install a 60A breaker (Eaton BR 2 series or equivalent) on the main busbar in the designated area). When the system is commissioned, the power to the EV charger will have to flow trough the breaker. If the breaker is in the off position, the power flow is prevented. The cable that connects the breaker to the contactor is installed in the SEP from the factory and is connected to the contactor. All that is remaining is to connect the other end of the cable to the breaker.

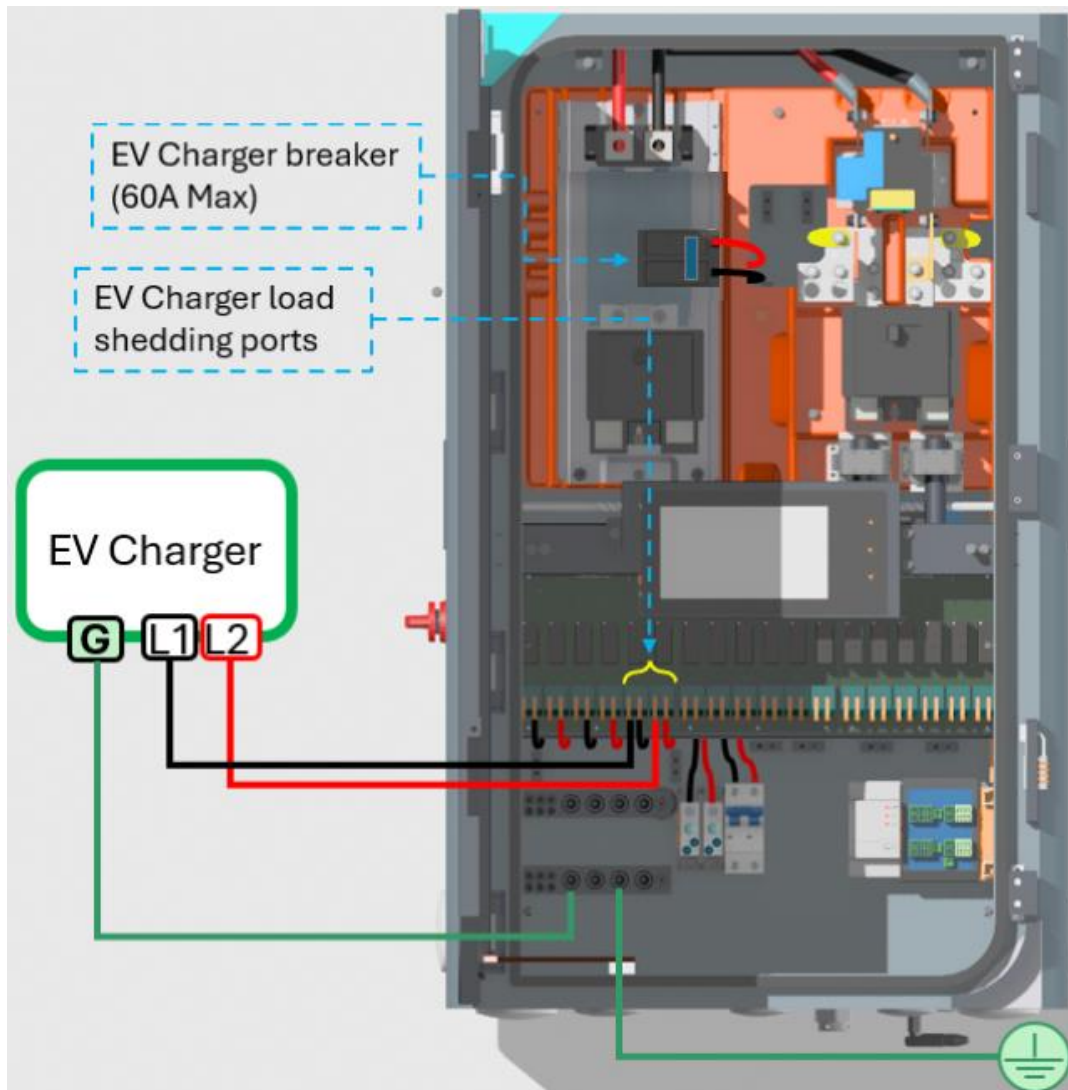

Appendix D: Water-resistant communication connections

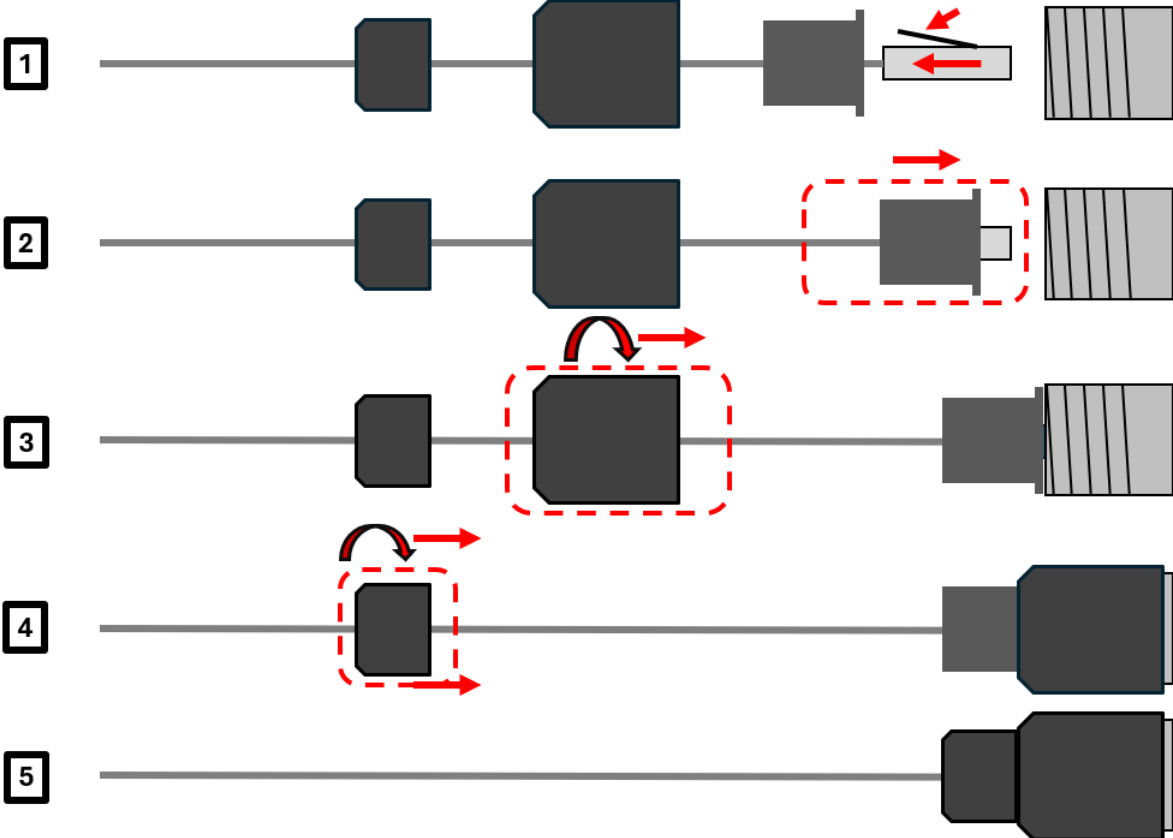

Appendix E: Additional eSTOP Switch Connection

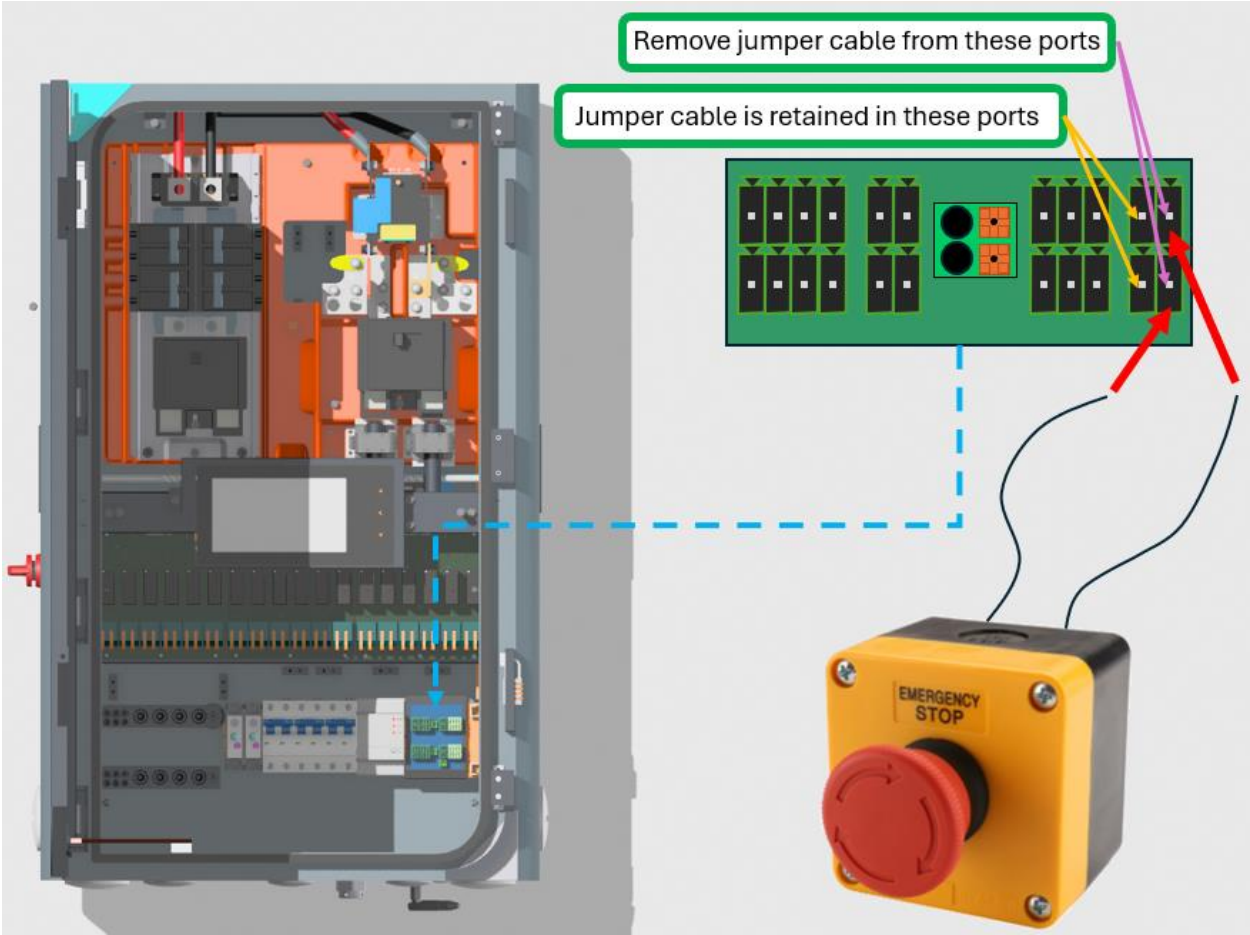

Appendix F: Diagram for longer SEP-Inv. Comms. Cable

